

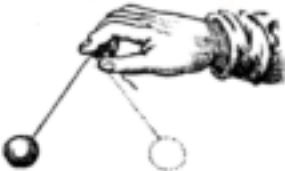













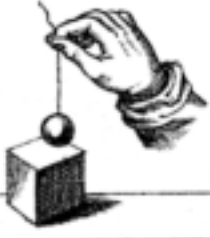
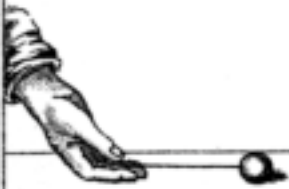
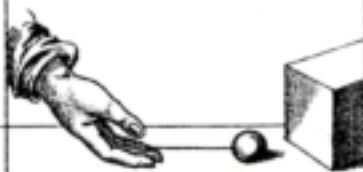

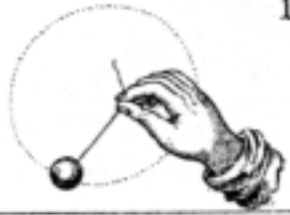

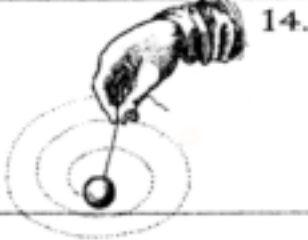
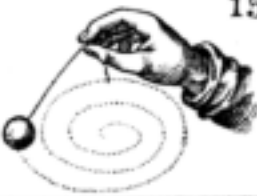
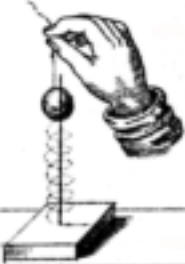



<p>1.</p> 	<p>2.</p> 	<p>3.</p> 	<p>4.</p> 
<p>Vor, zurück.</p>	<p>Hin, her.</p>	<p>Herüber.</p>	<p>Hinüber.</p>
<p>5.</p> 	<p>6.</p> 	<p>7.</p> 	<p>8.</p> 
<p>Herauf, hinab.</p>	<p>Hinab, herauf.</p>	<p>Tipp, tapp, tapp.</p>	<p>Tief hinein.</p>
<p>9.</p> 	<p>10.</p> 	<p>11.</p> 	<p>12.</p> 
<p>Roll, roll, roll.</p>	<p>Komm zurück.</p>	<p>Rund um, rund um.</p>	<p>Links um.</p>
<p>13.</p> 	<p>14.</p> 	<p>15.</p> 	<p>16.</p> 
<p>Rechts um.</p>	<p>Jmmer enger.</p>	<p>Jmmer weiter.</p>	<p>Jmmer höher.</p>
<p>17.</p> 	<p>18.</p> 	<p>19.</p> 	<p>20.</p> 
<p>Jmmer tiefer.</p>	<p>Zieh, zieh, zieh.</p>	<p>Bautz: da fällt d. Ball.</p>	<p>Bim, baum, baum.</p>
<p>21.</p> 	<p>22.</p> 	<p>23.</p> 	<p>24.</p> 
<p>Fort ist der Ball.</p>	<p>Da ist der Ball.</p>	<p>Fang den Ball.</p>	<p>Halte den Ball.</p>

<p>1</p> 	<p>2.</p> 	<p>3.</p> 
<p>Rund um, rund um, Das ist meine Freude.</p>	<p>Wie ich mich auch kehr u wende, Die Kugel zeig ich ohne Ende.</p>	<p>Da steh nun fest, Steh fest, steh fest.</p>
<p>4.</p> 	<p>5.</p> 	<p>6.</p> 
<p>Er wanket hin, er wanket her, Zu stehen so wird ihm zu schwer.</p>	<p>Er steht auf einem Fuß, Warum er das wohl muß.</p>	<p>Schau nur wie ich leicht mich dreh, Wenn auf einem Bein ich steh.</p>
<p>7</p> 	<p>8.</p> 	<p>9.</p> 
<p>Eine siehst du nur allein, Wo mögen wohl die andern sein.</p>	<p>Zwei nur lassen hier sich sein Wie mag es mit den andern stehn?</p>	<p>Wie ich mich auch kehr u neige, Drei auf einmal ich nur zeige.</p>
<p>10.</p> 	<p>11.</p> 	<p>12.</p> 
<p>Lass mein Schwingen, Freud dir bringen.</p>	<p>Jetzt häng ich mit der Kante am Bande, Und schwing mich gern, dir nah, dir fern.</p>	<p>Schwing ich mich an einer Ecke, Sieh, wie lang ich mich dann strecke.</p>

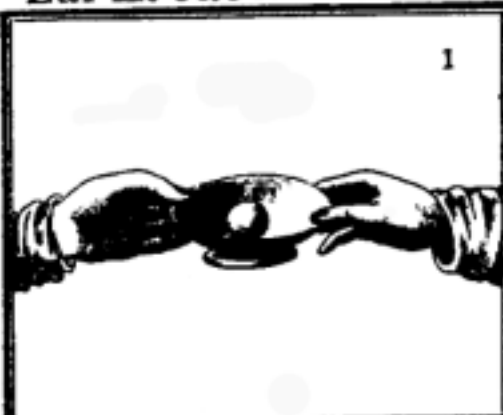
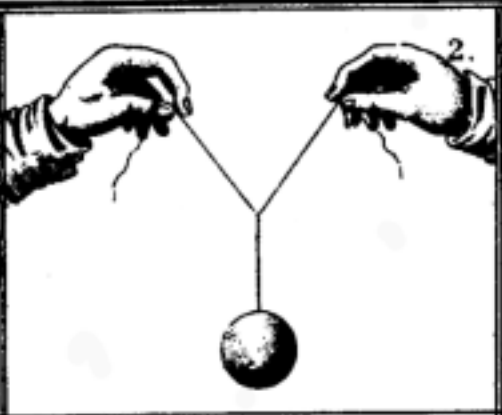
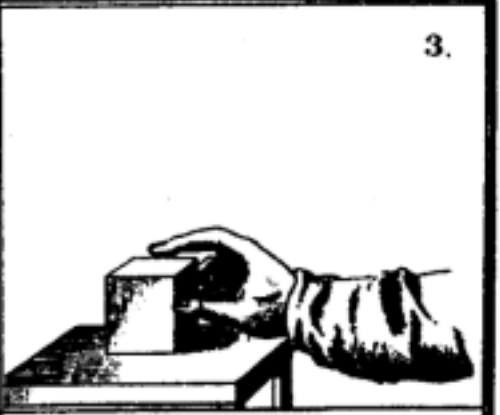
<p>13.</p>	<p>14.</p>	<p>15.</p>
<p>Mach mich um mich selber drehn, Eine Walze lafs ich sehn.</p>	<p>Mach mich um mich selber drehen Einen Kreis lafs ich dir sehen.</p>	<p>Dreh'ich mich um der Ecken zwei, Zeig ich dir gar mancherlei.</p>
<p>16.</p>	<p>17.</p>	<p>18.</p>
<p>Wie mich die starke Hand umschnellt, So das Drehen mir gefällt.</p>	<p>Ohne Ende ohne Ende, Mich bald links, bald rechts umwende.</p>	<p>Weil mich fremde Kräfte drehn, Kann ich niemals stille stehn.</p>
<p>19.</p>	<p>20.</p>	<p>21.</p>
<p>Soll ich mich fast rund dir zeigen, Lafs mich tanzen runde Reigen.</p>	<p>Mache auf u. ab mich winden, Schöne Kreise sollst du finden.</p>	<p>Wie mich schnell die Finger drehn, Lafs ich Rad, lafs Walze sehn.</p>
<p>22.</p>	<p>23.</p>	<p>24.</p>
<p>Dreh mich um, dreh mich um, Zeig ich was gerad ist krumm.</p>	<p>Tief u. Höhen lafs ich sehen, Wenn mich leicht die Finger drehen.</p>	<p>Ob gleich auf einer Fläche steh, Dennoch um mich selbst ich dreh.</p>

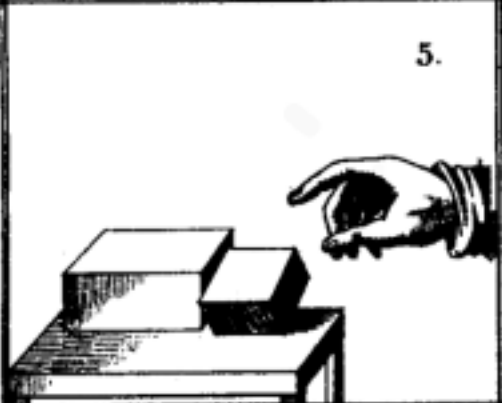
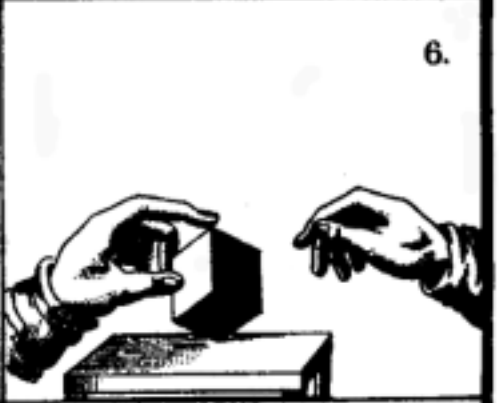

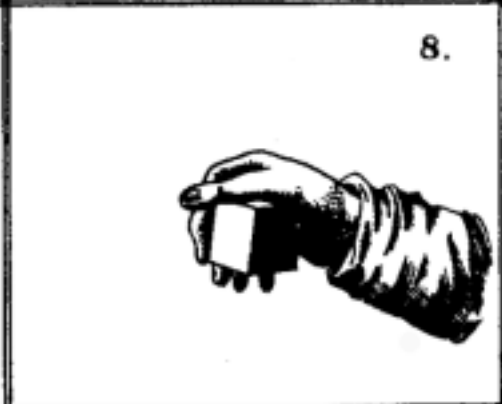
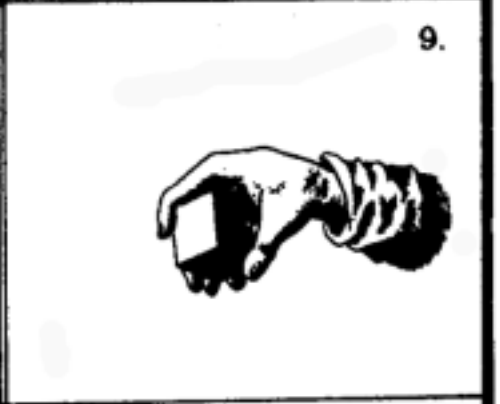
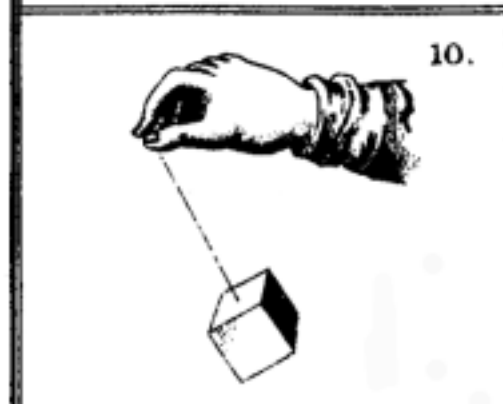
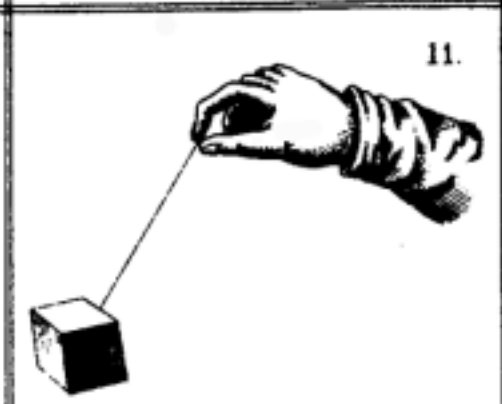
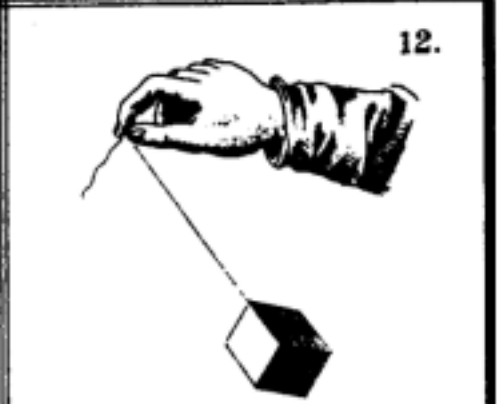
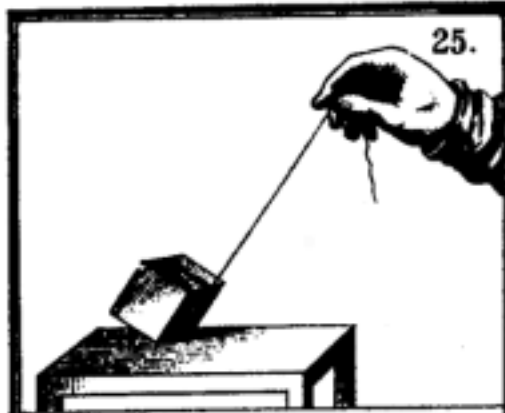
25.

Heb mich auf, so sink ich nieder,
Schreite vorwärts,kehr oft wieder.

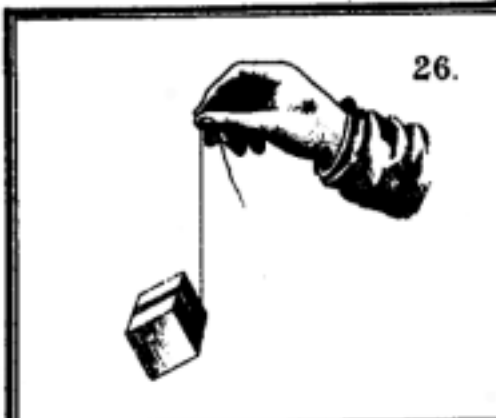

26.

Eilig hinab,
Roll ich steilab.



27.

Dien' ich dir zum Wagen,
Kann ich manches tragen.

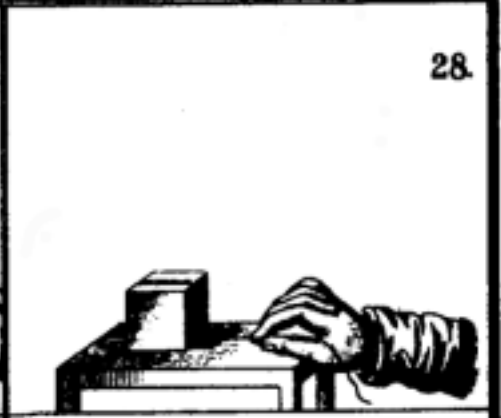

28.

Soll ich dir ein Schlitten sein,
Leicht fährst du mich ganz allein.

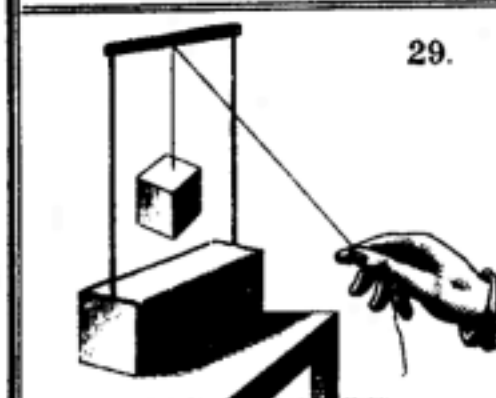

29.

Senkst du dich,so heb ich mich,
Hebst du dich,so senk ich mich.

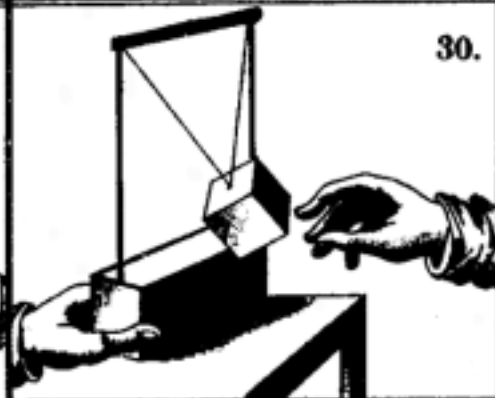

30.

Schaukeln das ist meine Lust,
Hoch ich steige,bald mich neige
Jimmer ich die Luft durchstreiche.

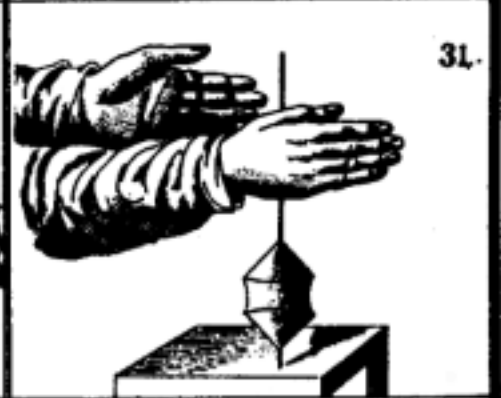

31.

Schau nur, wie ich tanze schön,
Lust'geres ist nicht zu sehn.



32.

So des Mühlrads Lauf,
Fällt das Wasser drauf.

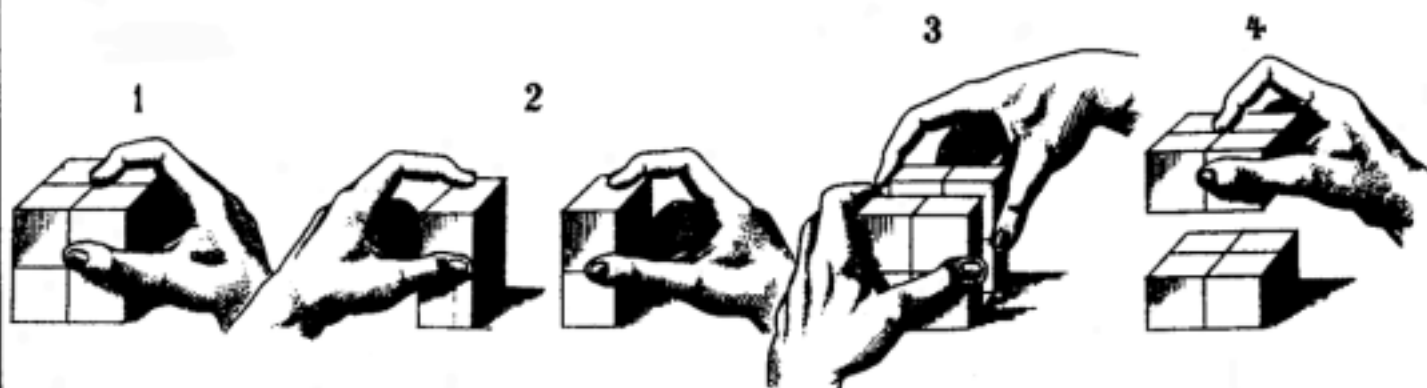

Lebensformen.



Kiste.



Thron.



Grossvaterstuhl.



2 Stühle.

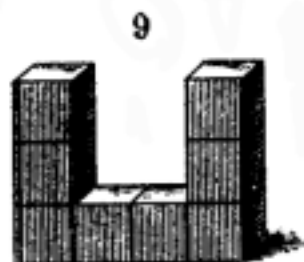

Burg.

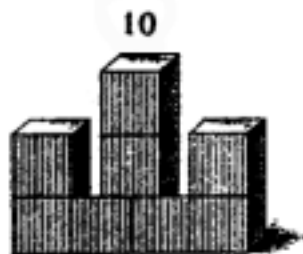

Schloss.

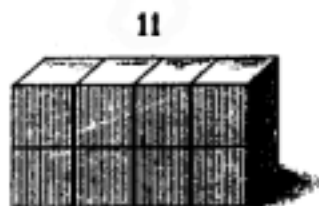

Mauer.

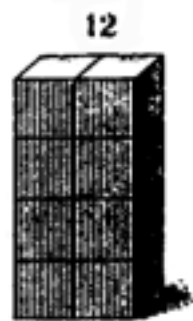

Hohe Mauer.

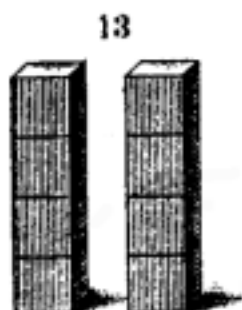

2 Säulen.

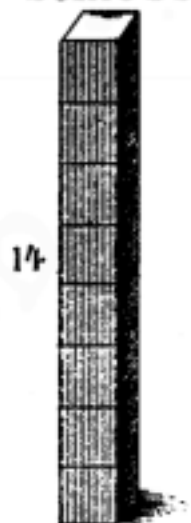

Säule.

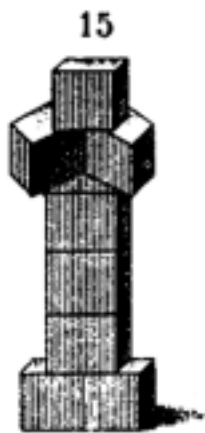

Wegweiser.



Kreuz.

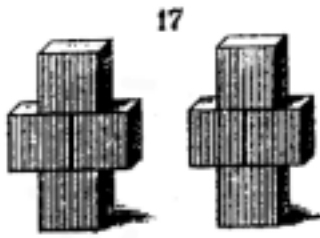

2 Kreuze.

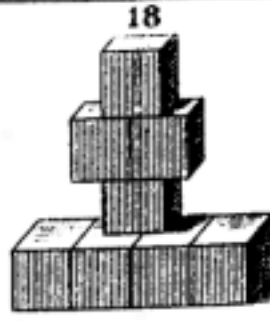

Denkstein.

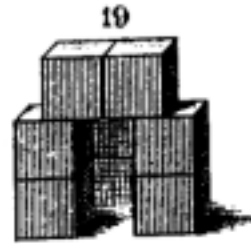

Schilderhaus.

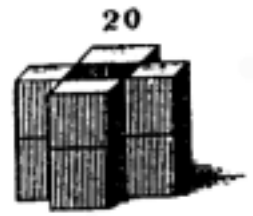

Schacht.

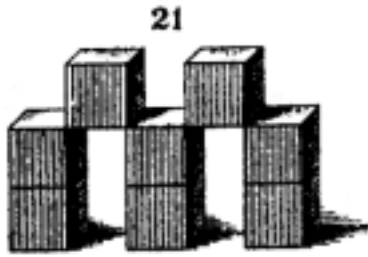

Thor mit 2 Durchgängen.

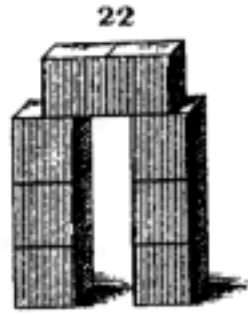

Thor.

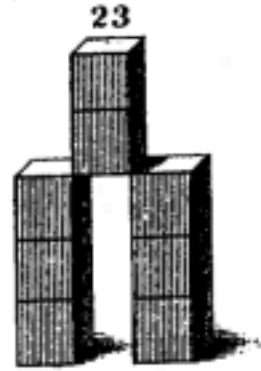

Ehrenpforte.

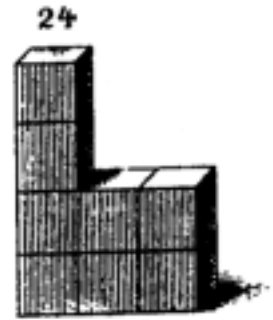

Kirche.

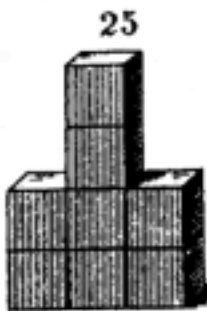

Rathaus.

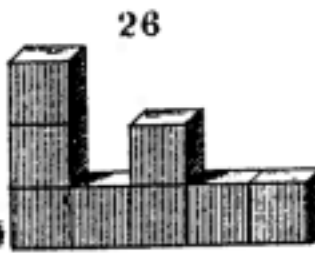

Locomotive.

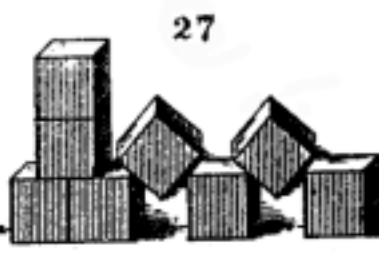

Ruine.

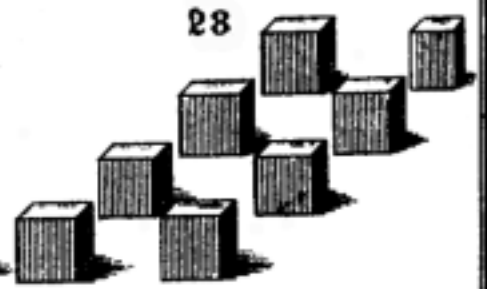

Allee.

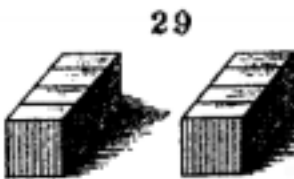

Bachufer.

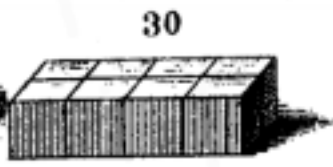

Brett.

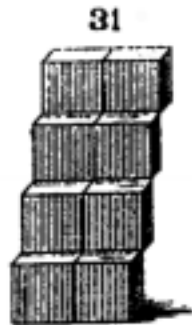

Treppe.



Freitreppe.

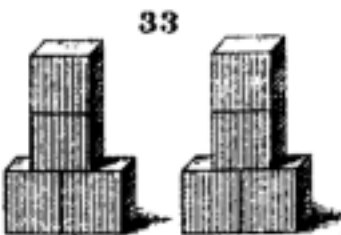

2 Denksteine.

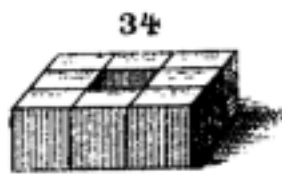

Trog.

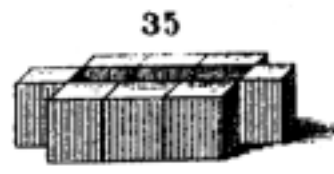

Trog.

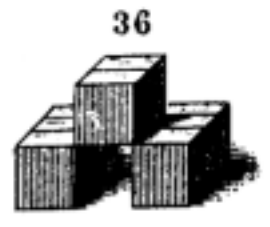

Tunnel.

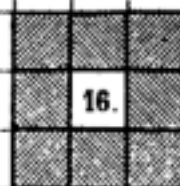
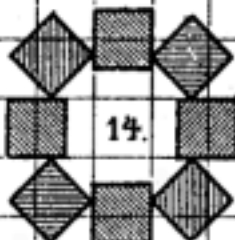
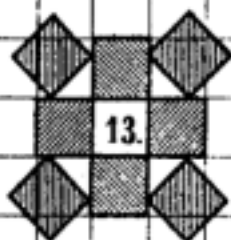
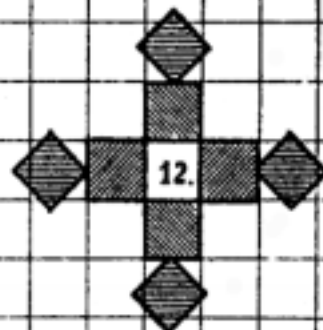
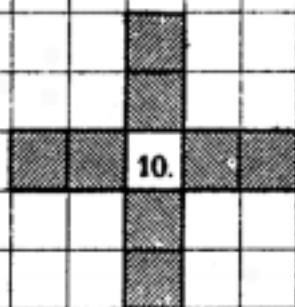
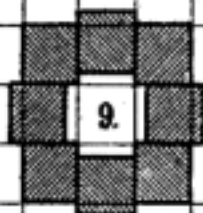
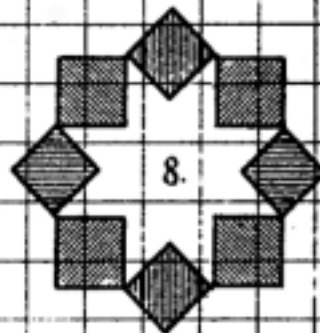
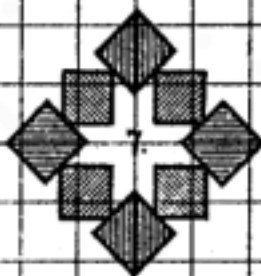
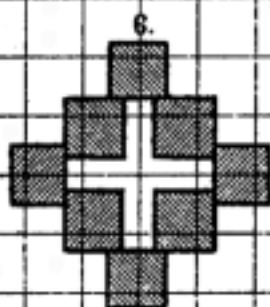
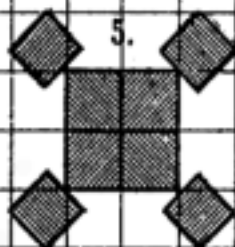
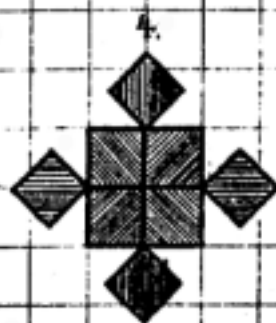
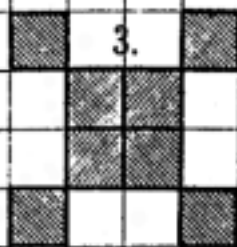
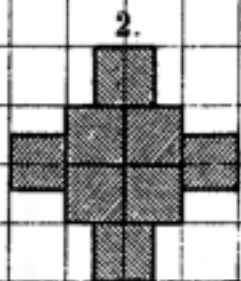
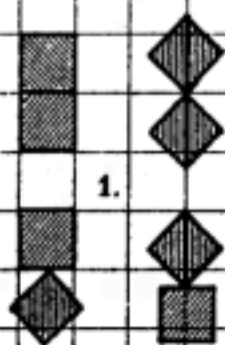

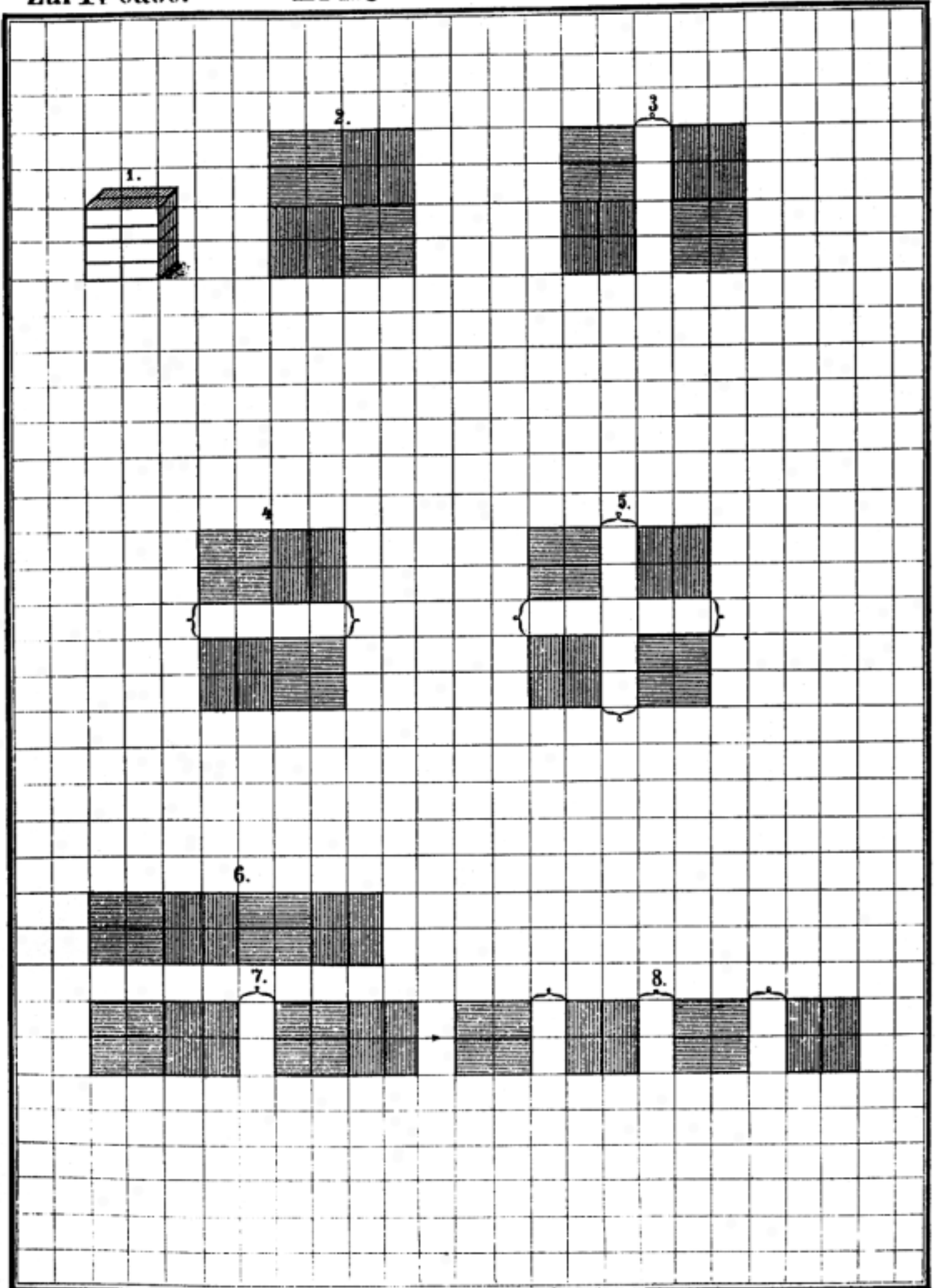

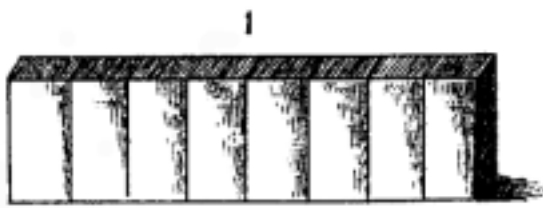

Lange Mauer.

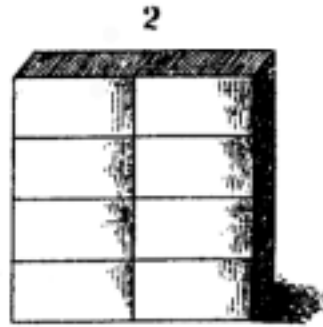

Hohe Wand.

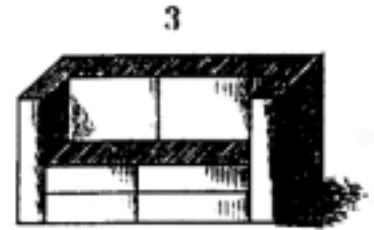

Sopha.

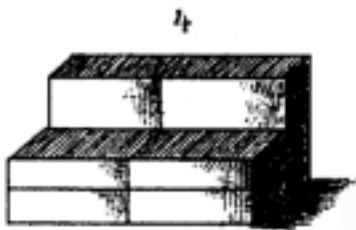

Gartenbank.

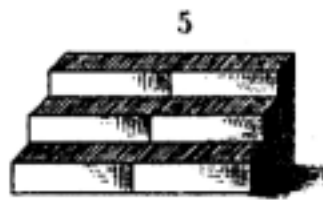

Treppe.



Stall.



Denkmal.



Tunnel.



Thor.

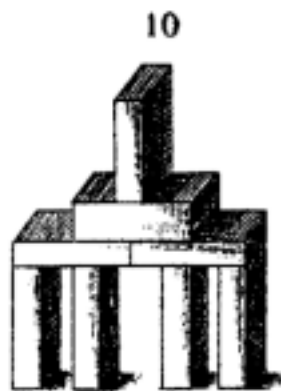

Thor.

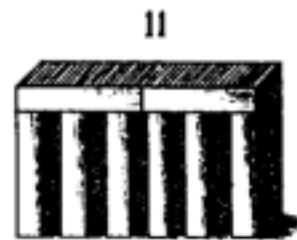

Bienenhaus.

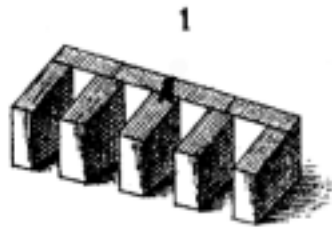

Stall.

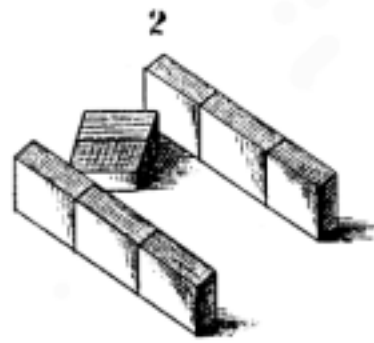

Kegelbahn.



Wassertrog.

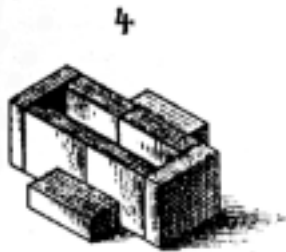

Trog.

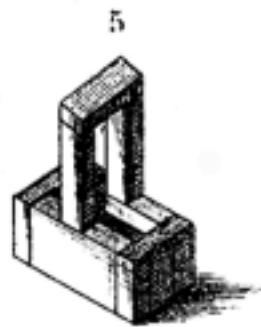

Korb.

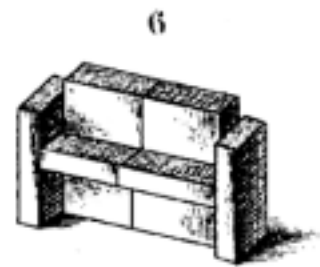

Pianino.

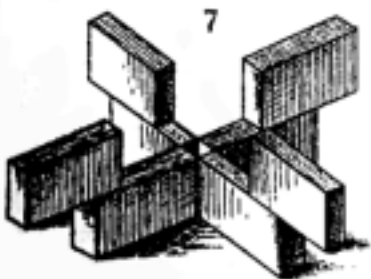

Karussell.



Soldaten.
(Fortpflanzung d. Bewegung.)

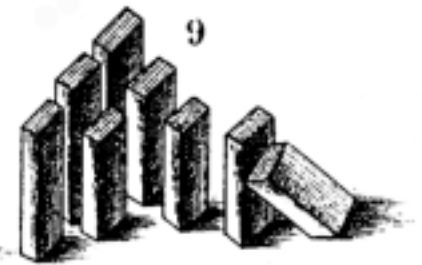

(Verstärkte Kraft.)

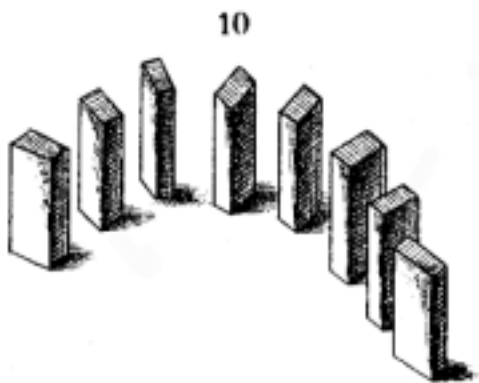

(Fortpflanzung d. Bewegung.)



Wendeltreppe.

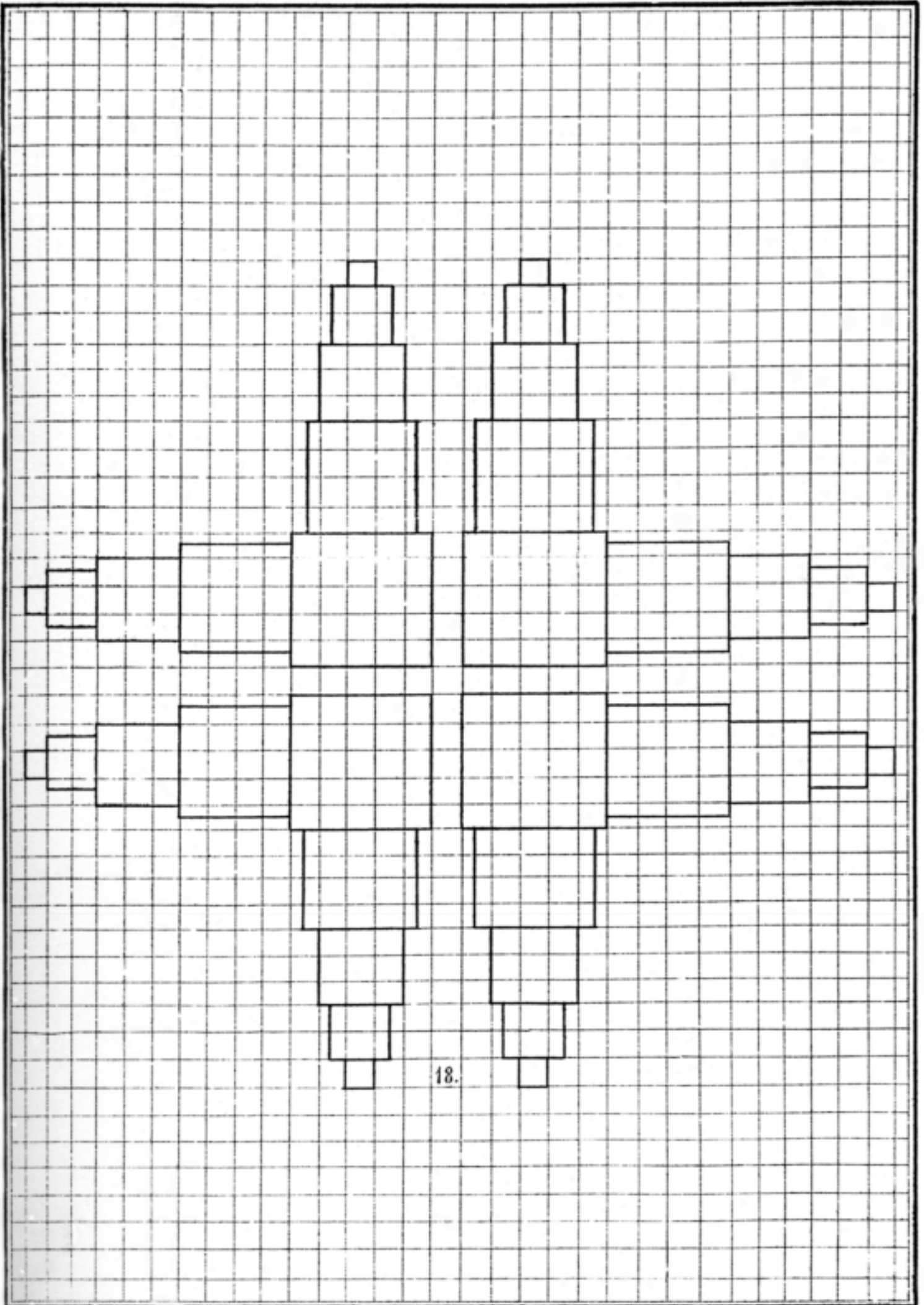

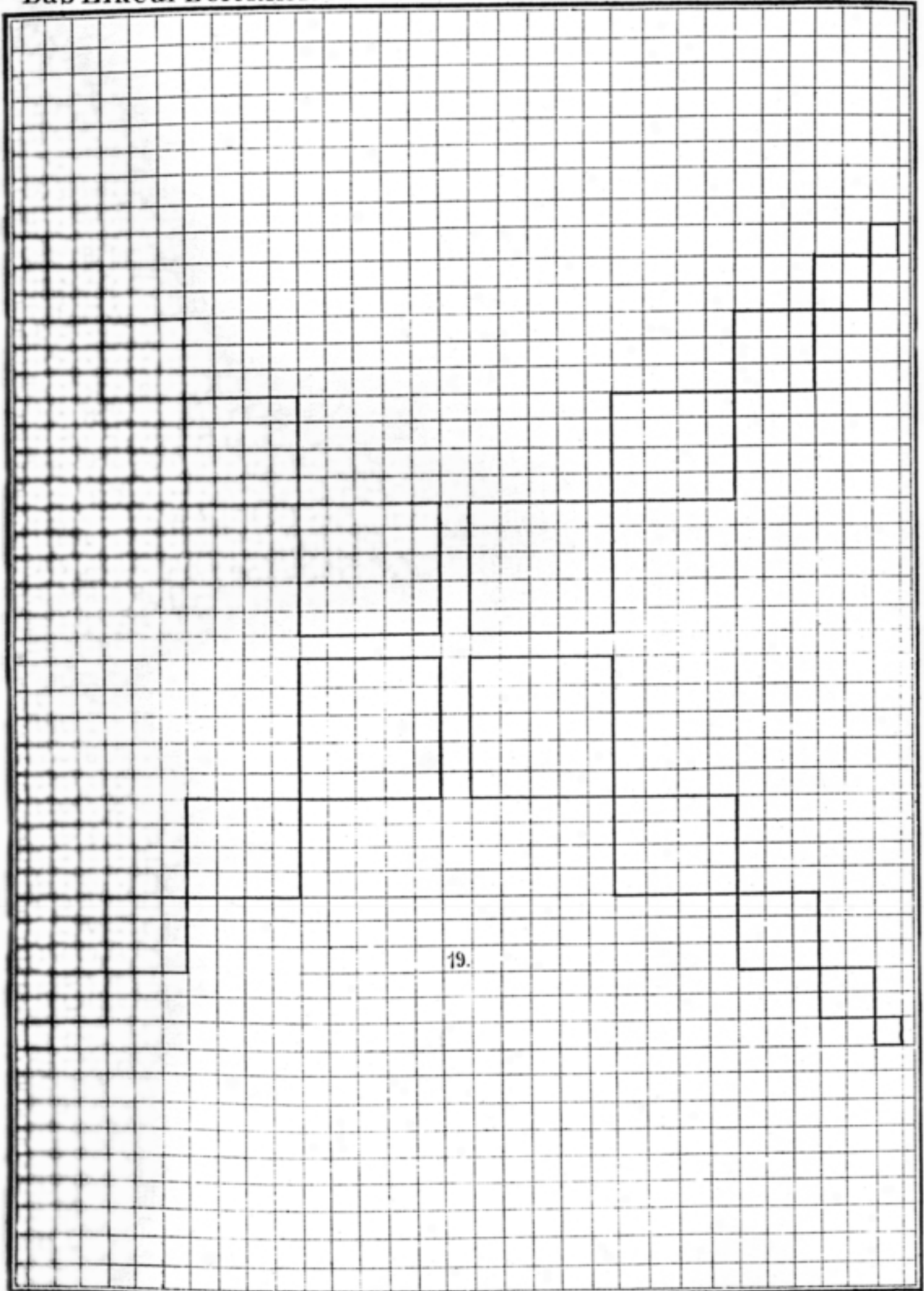

19.

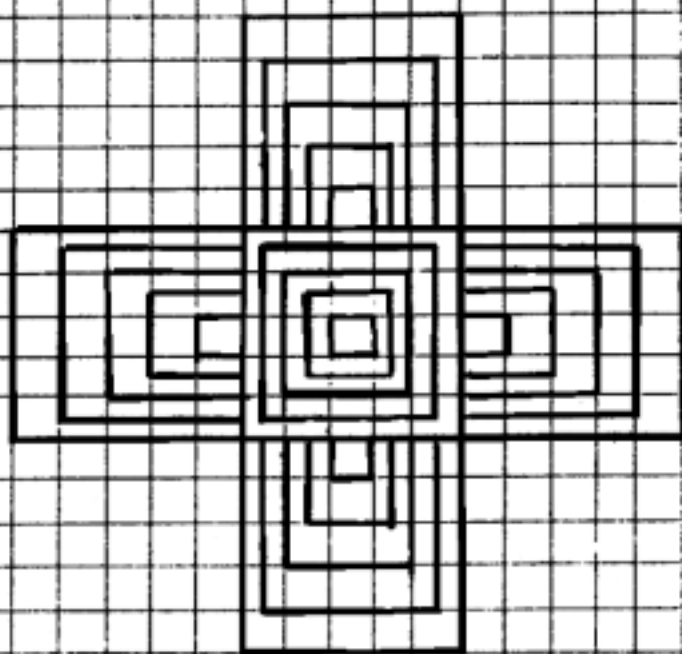

21.

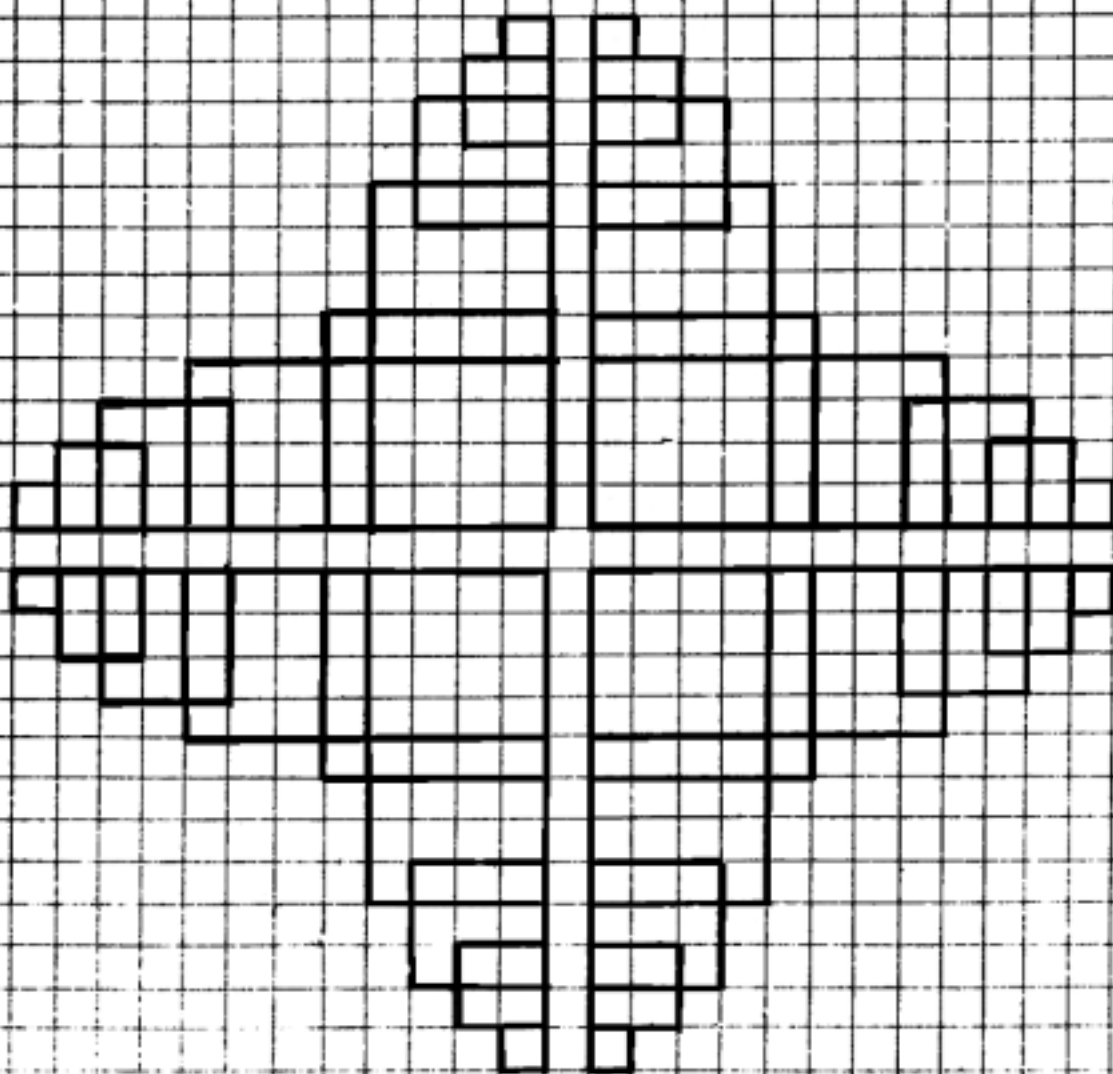

22.

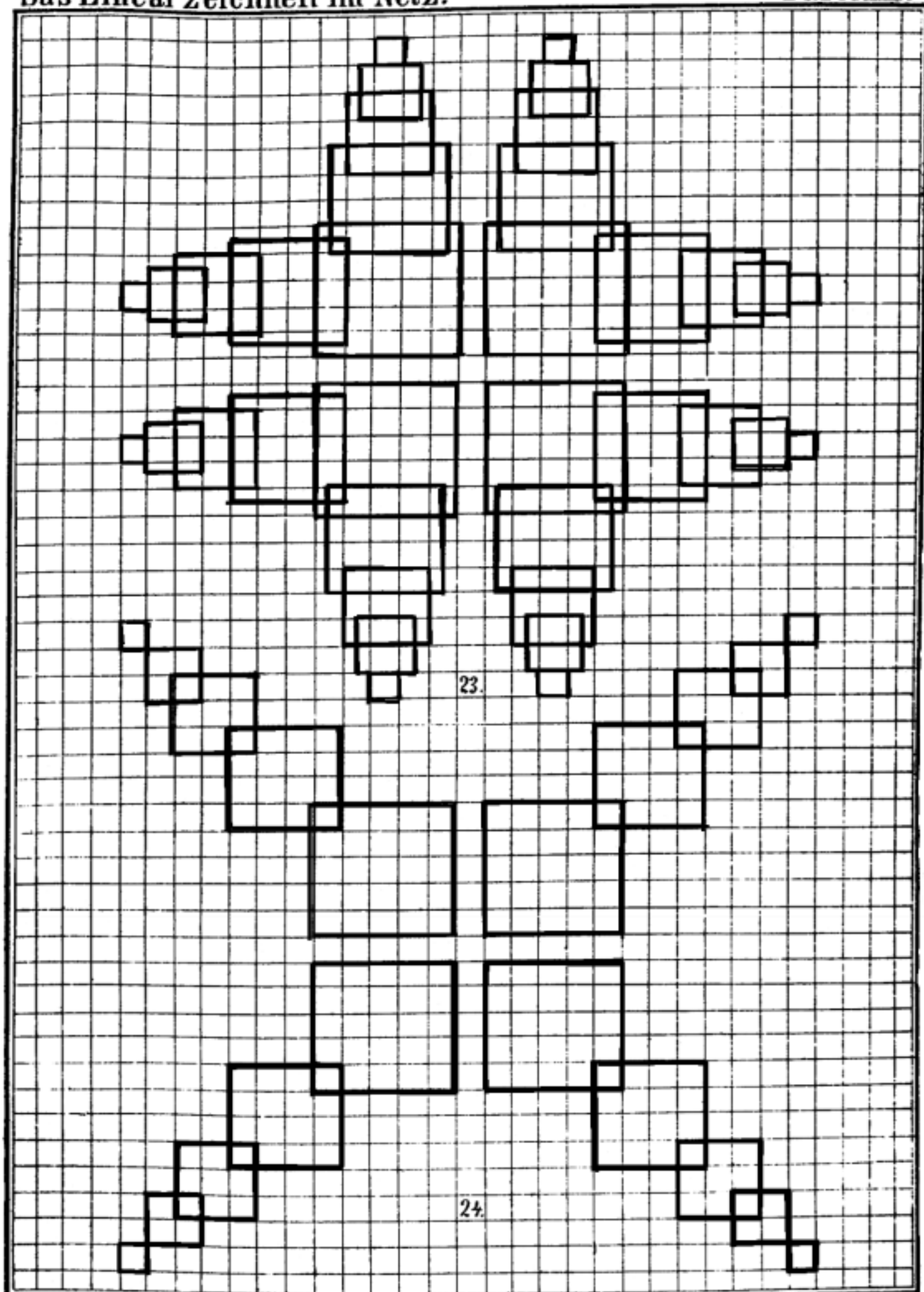

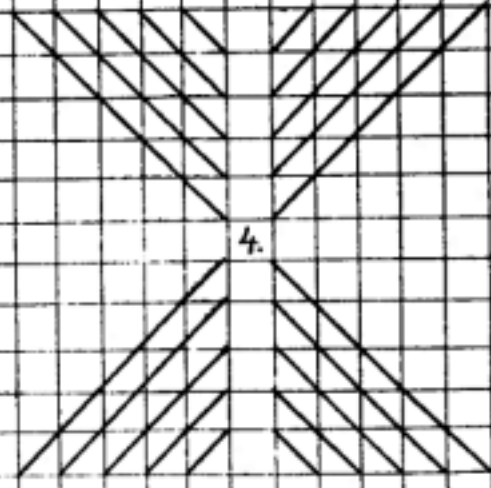
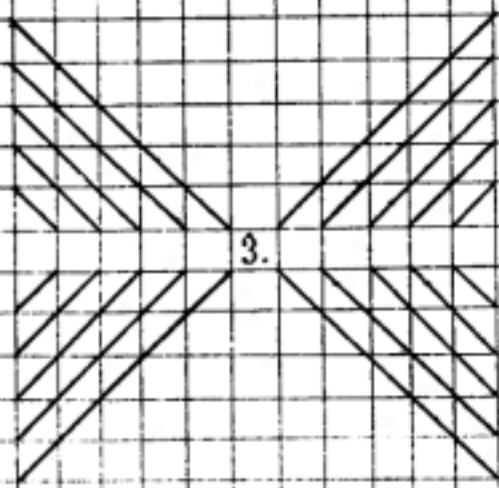
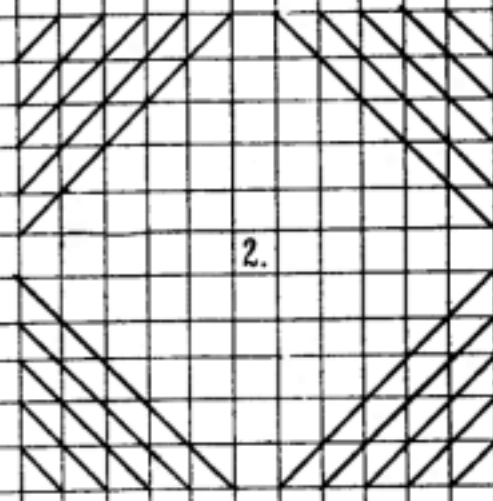
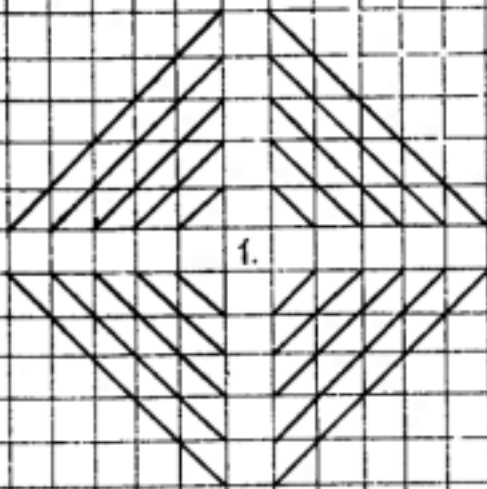
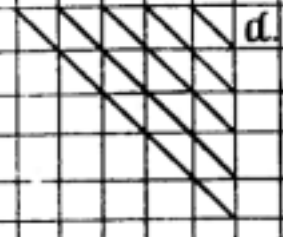
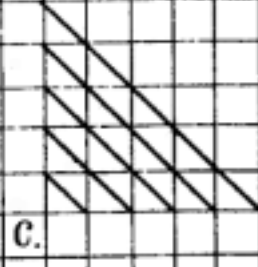
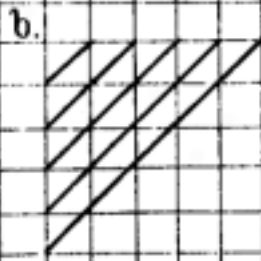
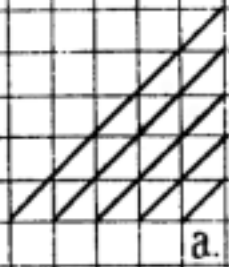

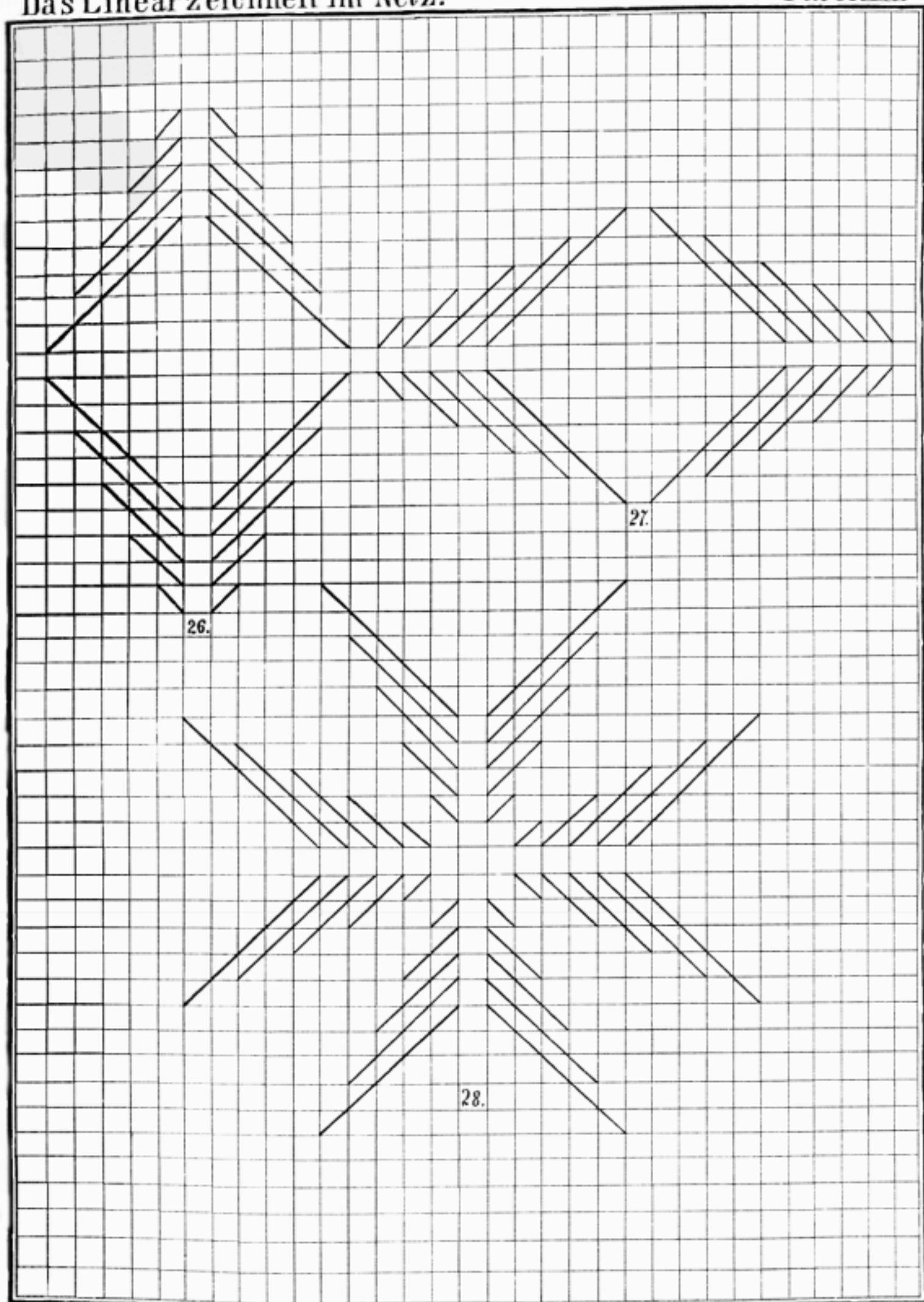

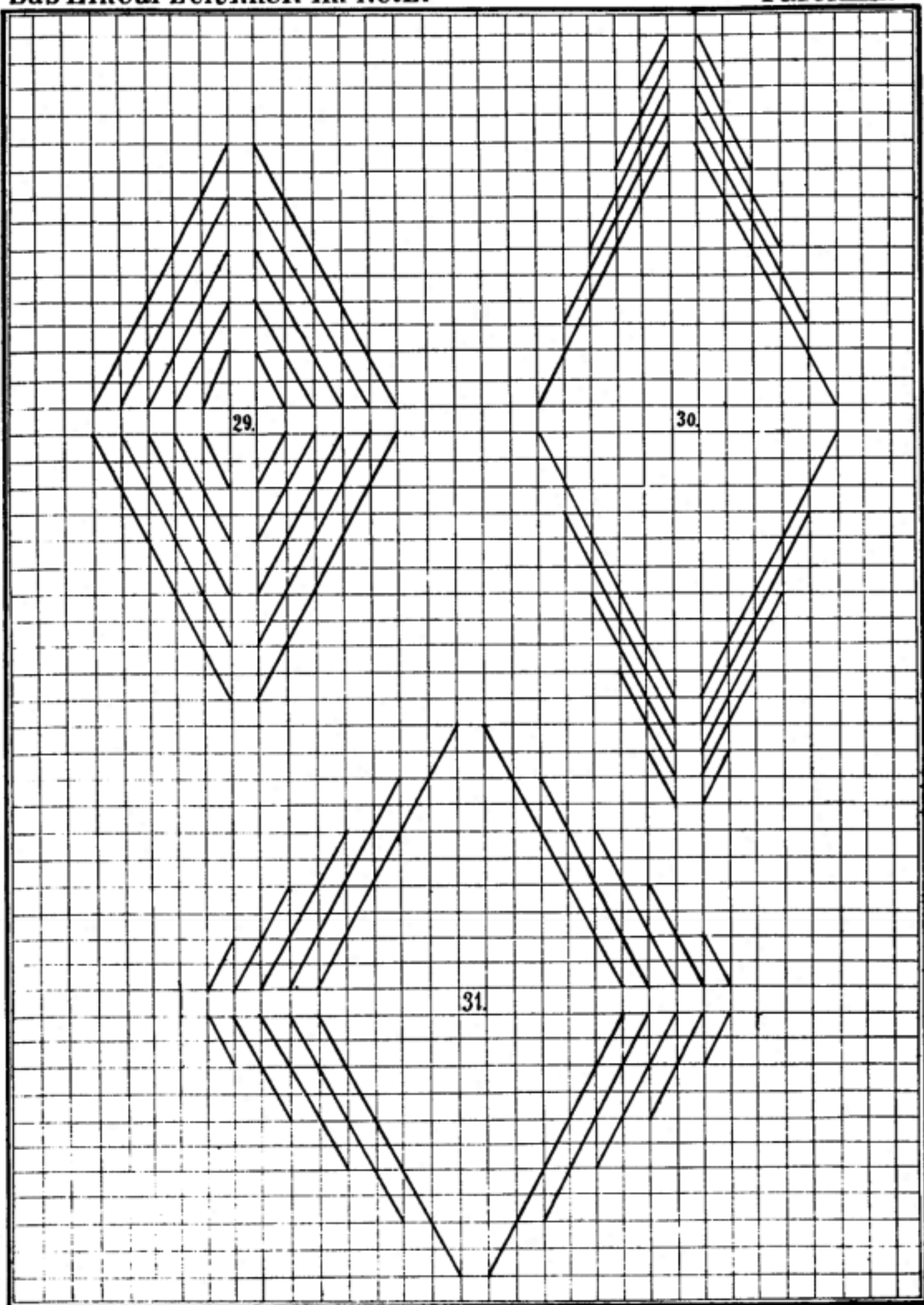

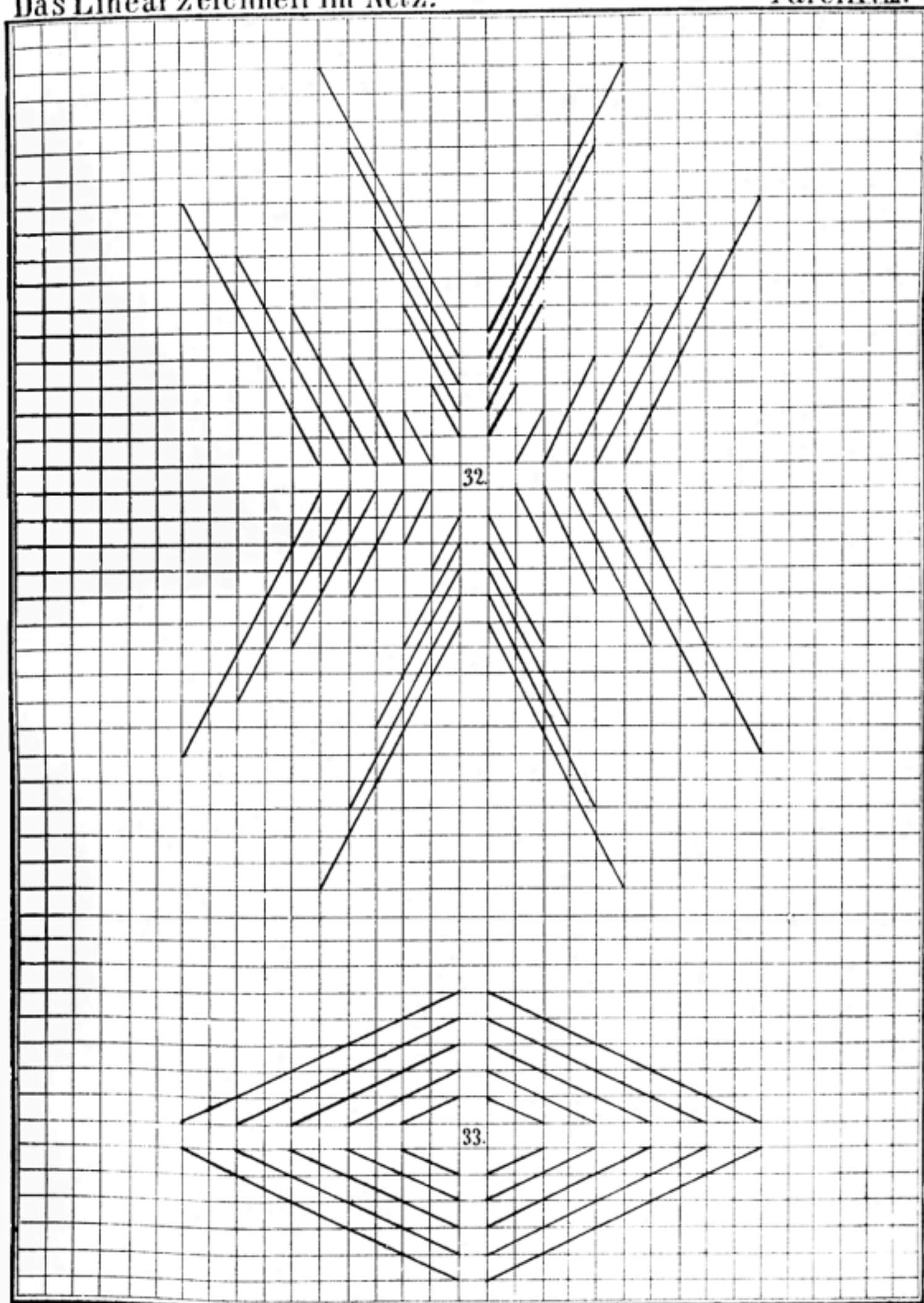

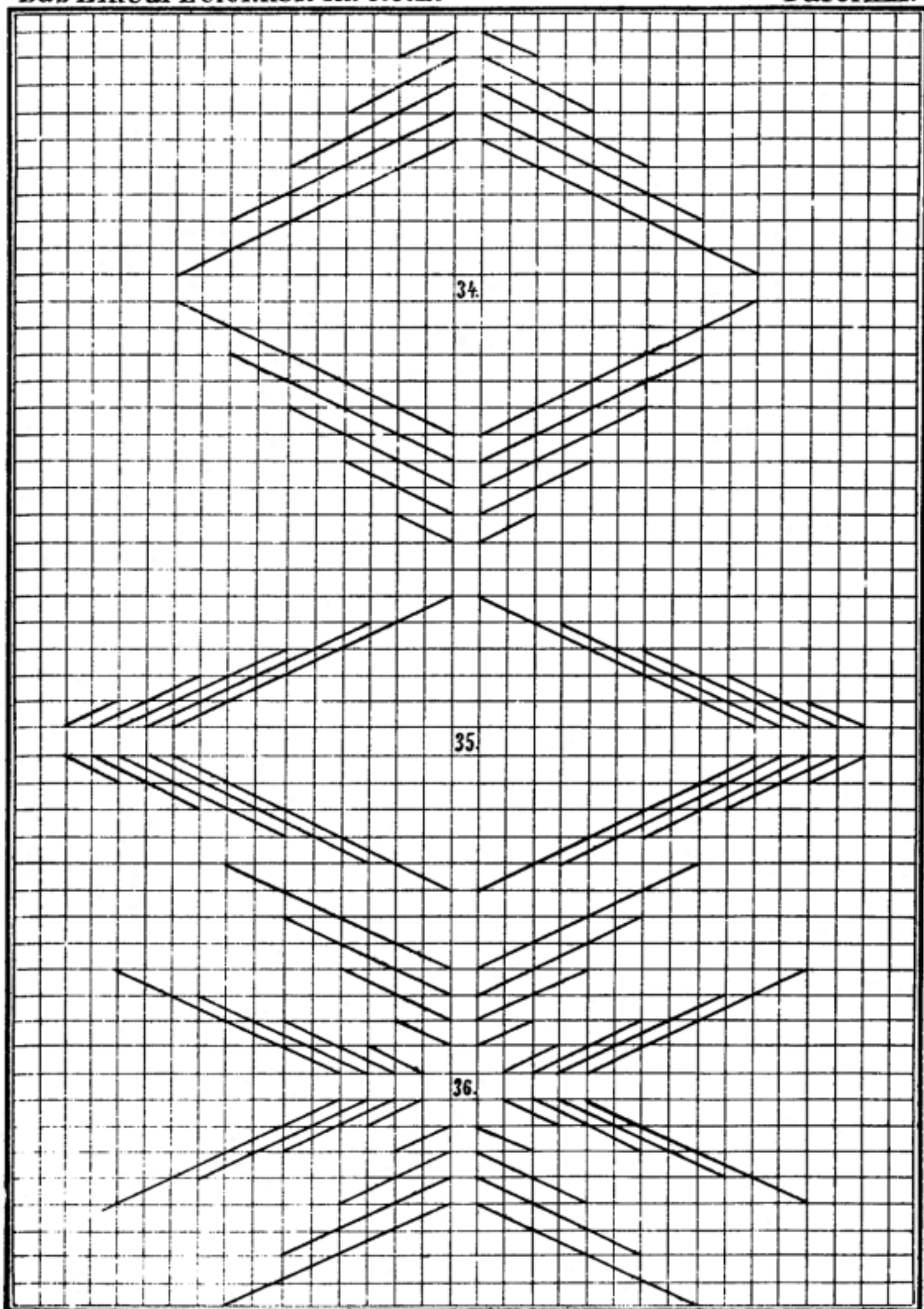

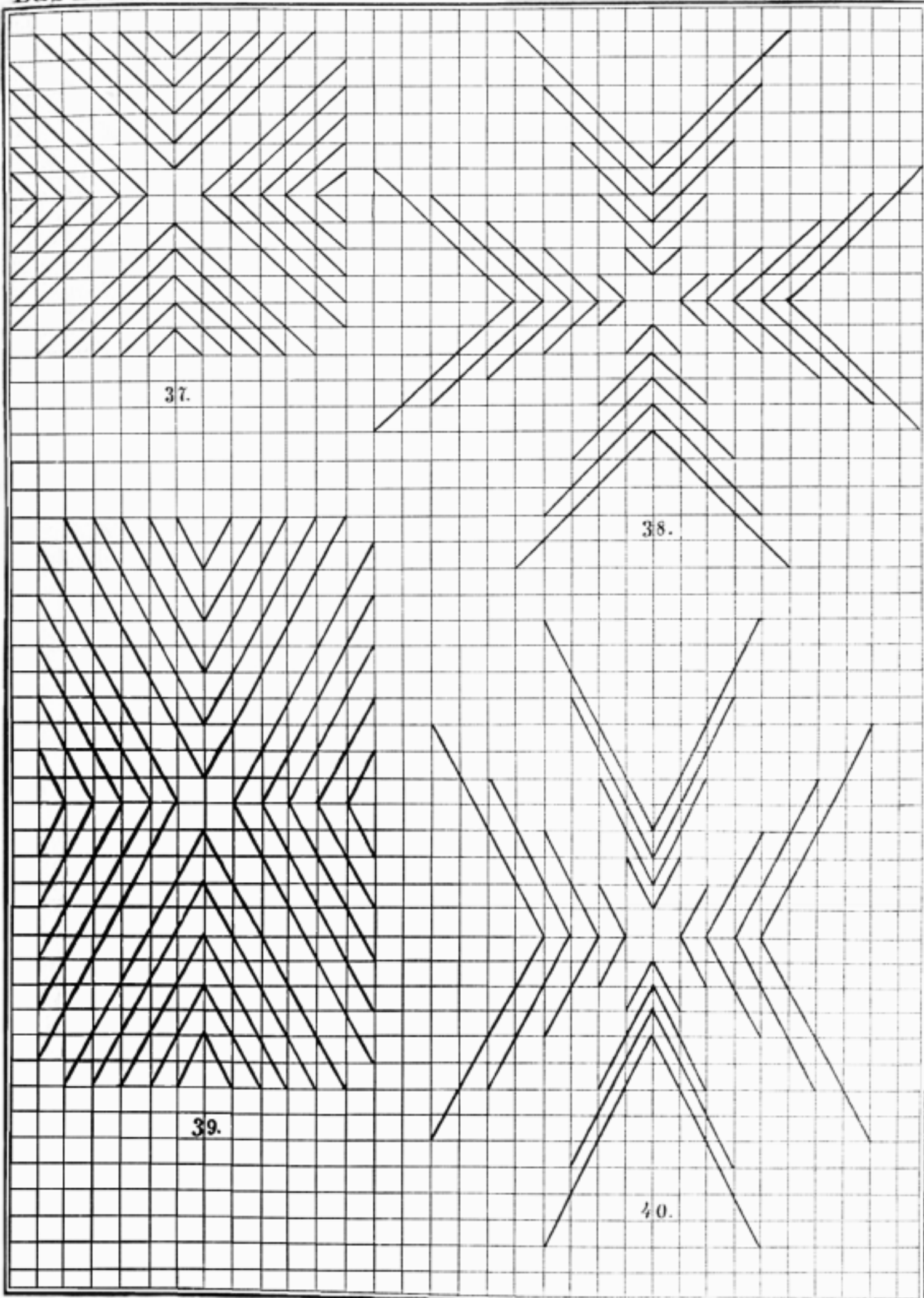

37.

38.

39.

40.

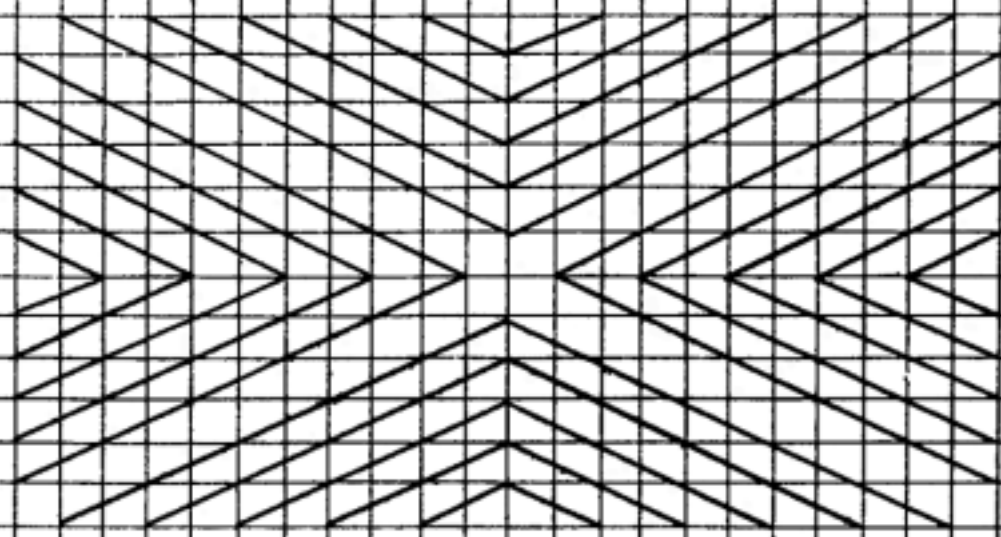

41.

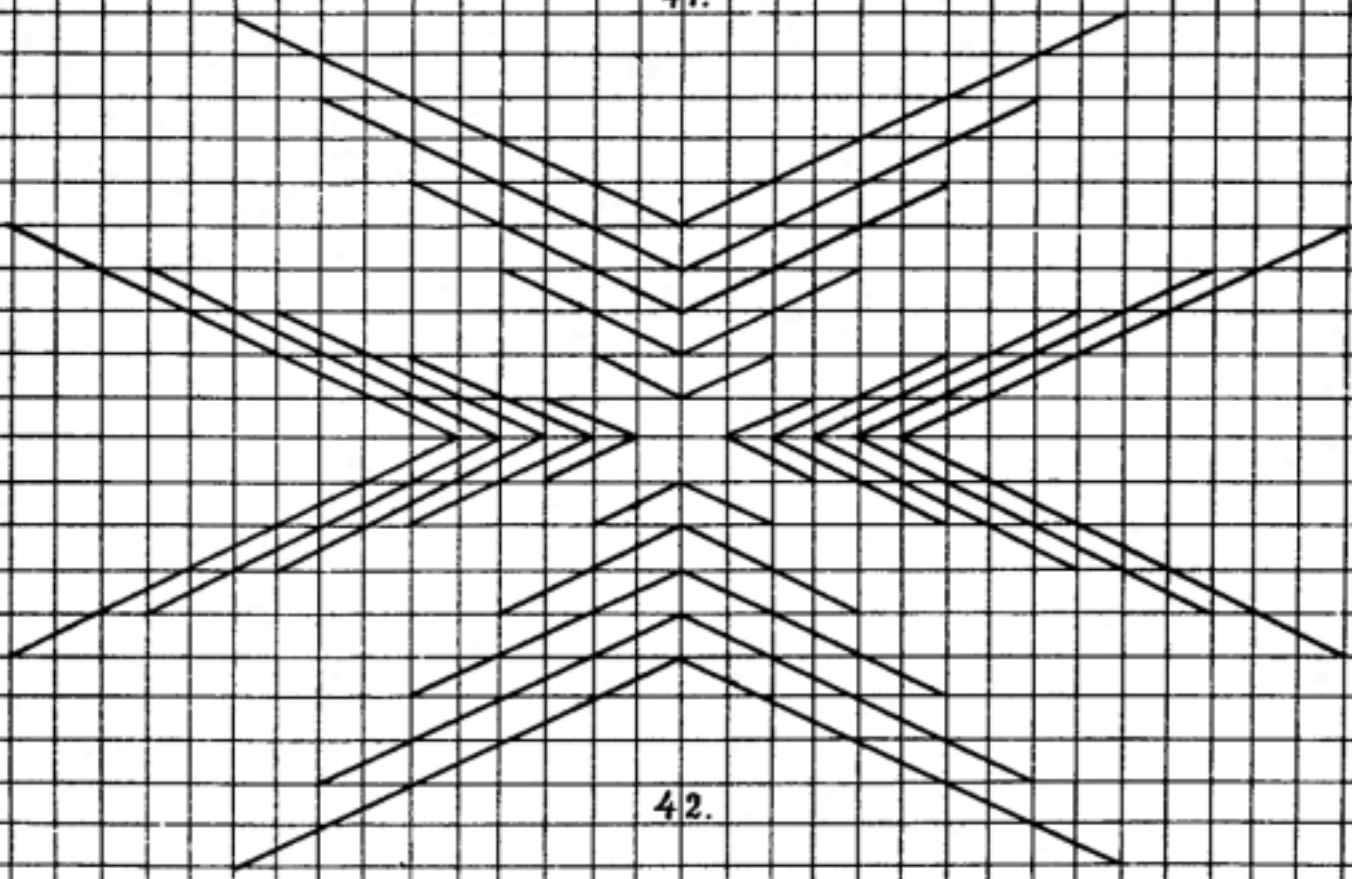

42.

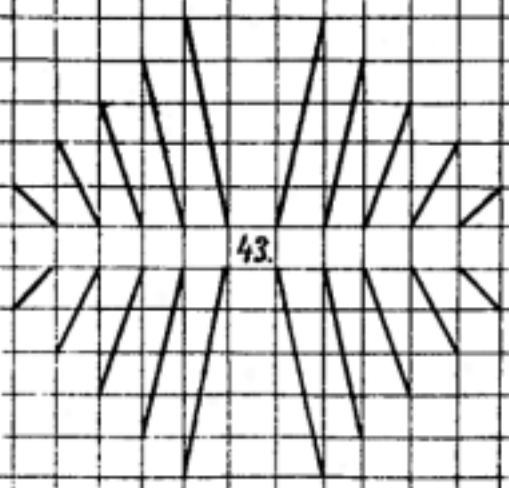

43.

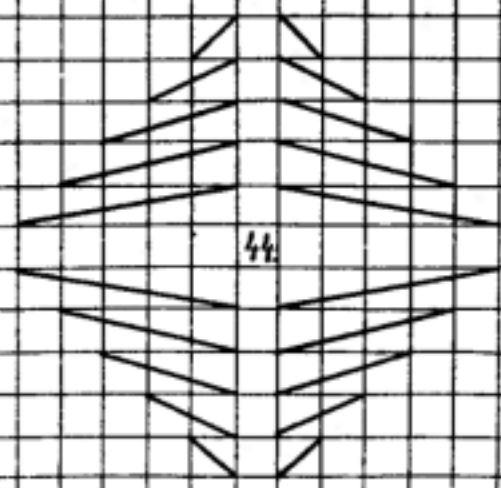

44.

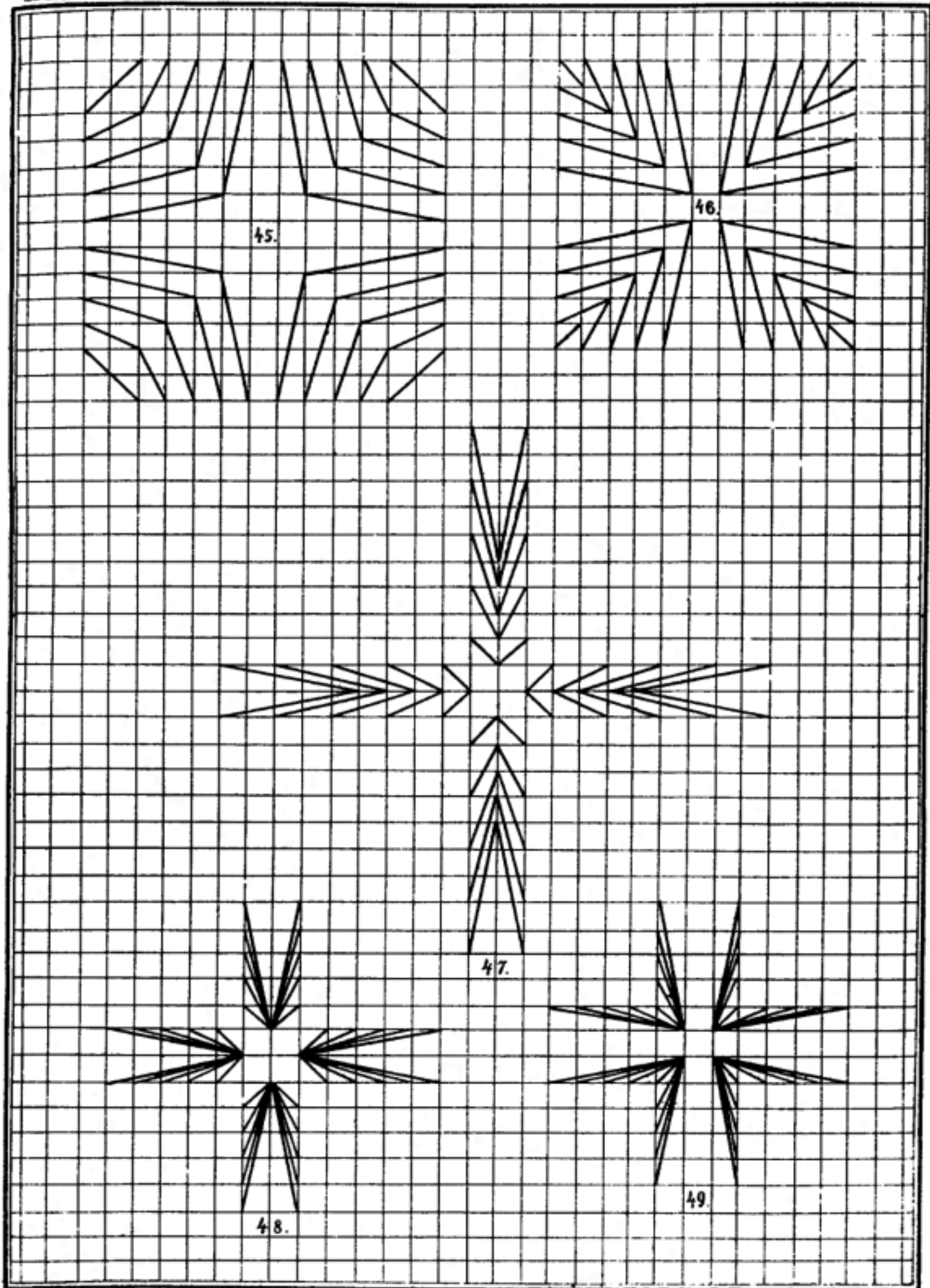

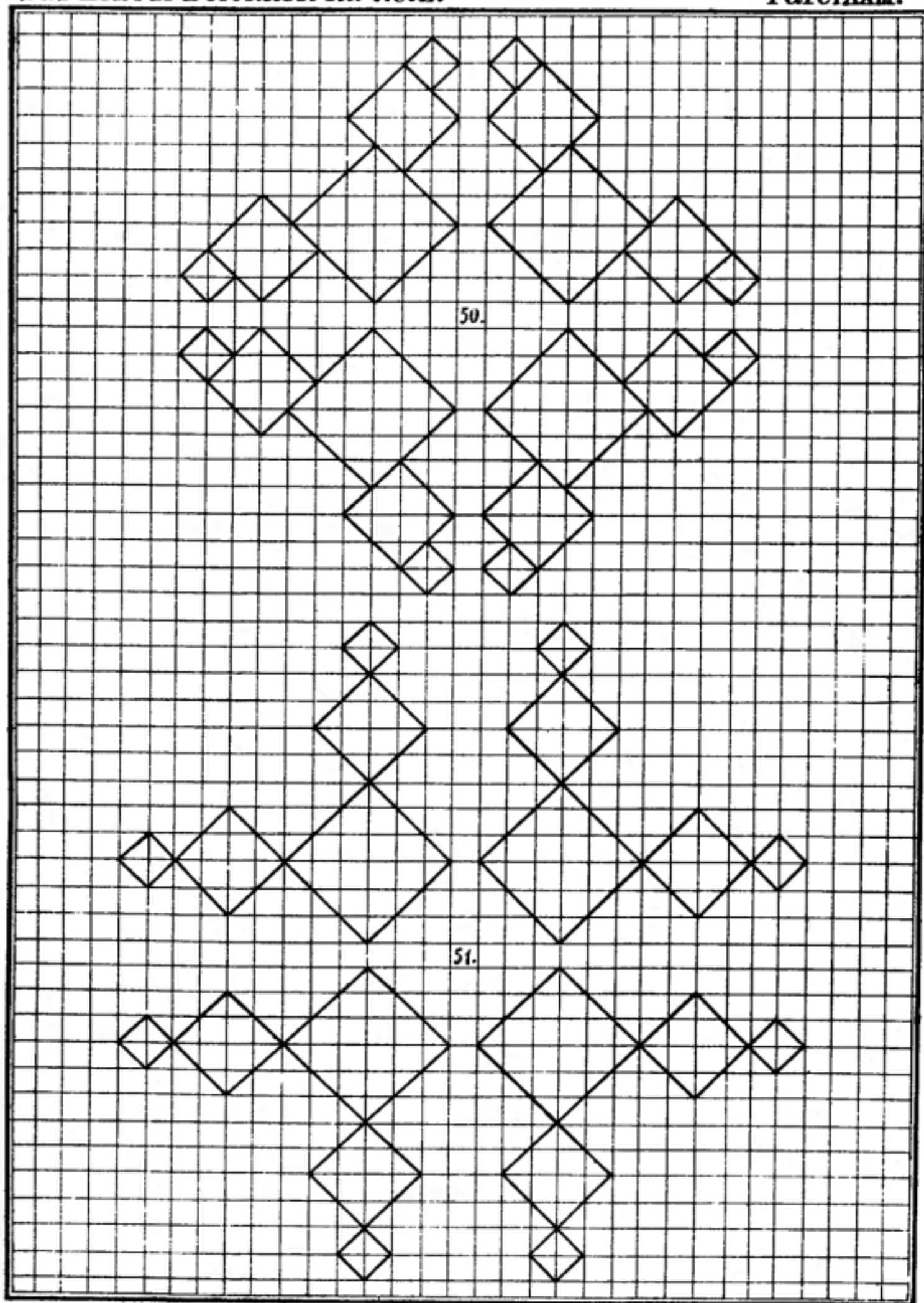

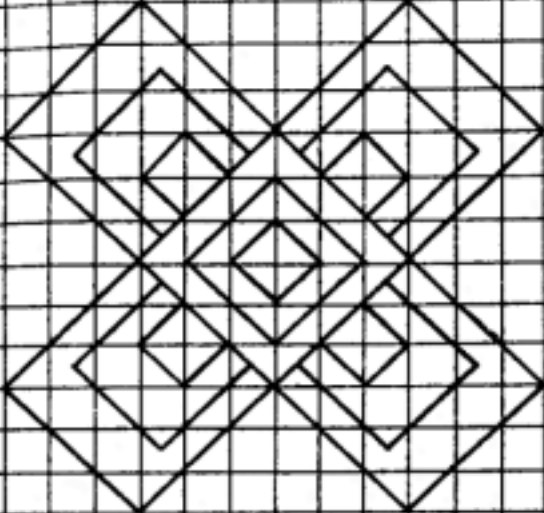

52.

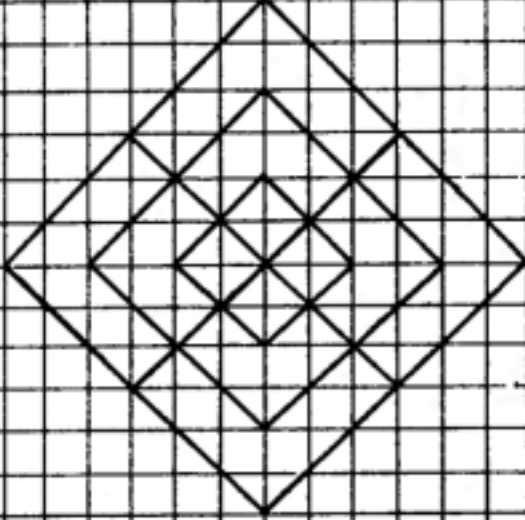

53.

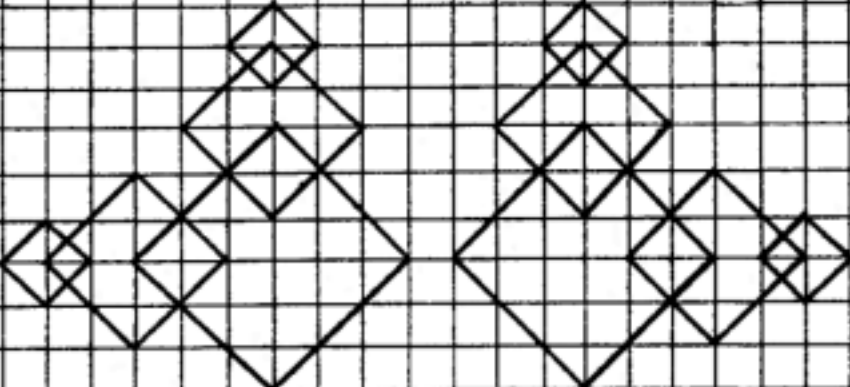

54.

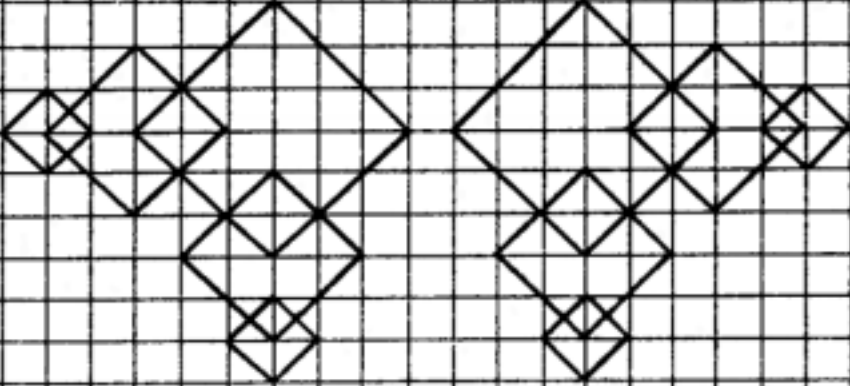

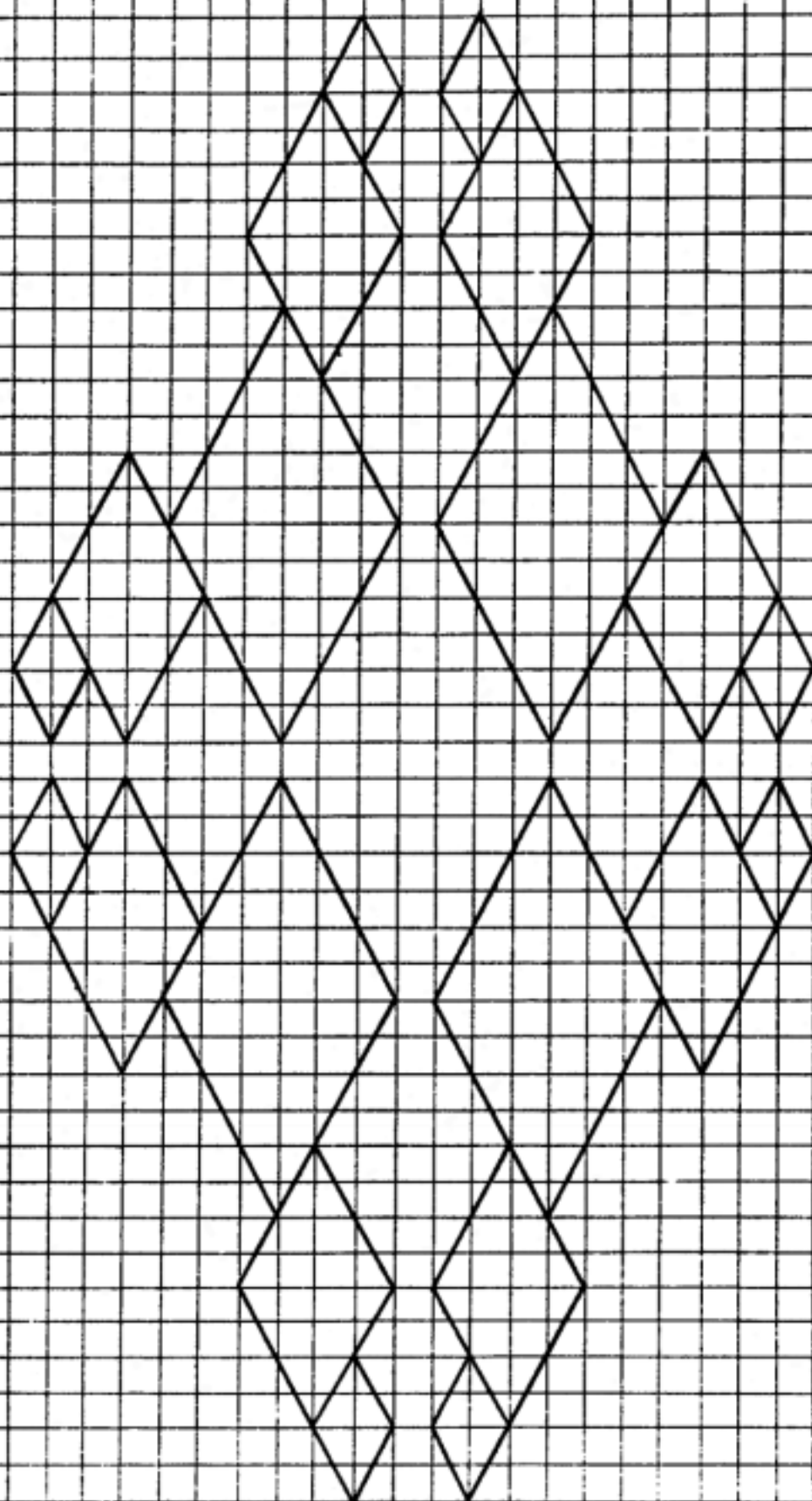

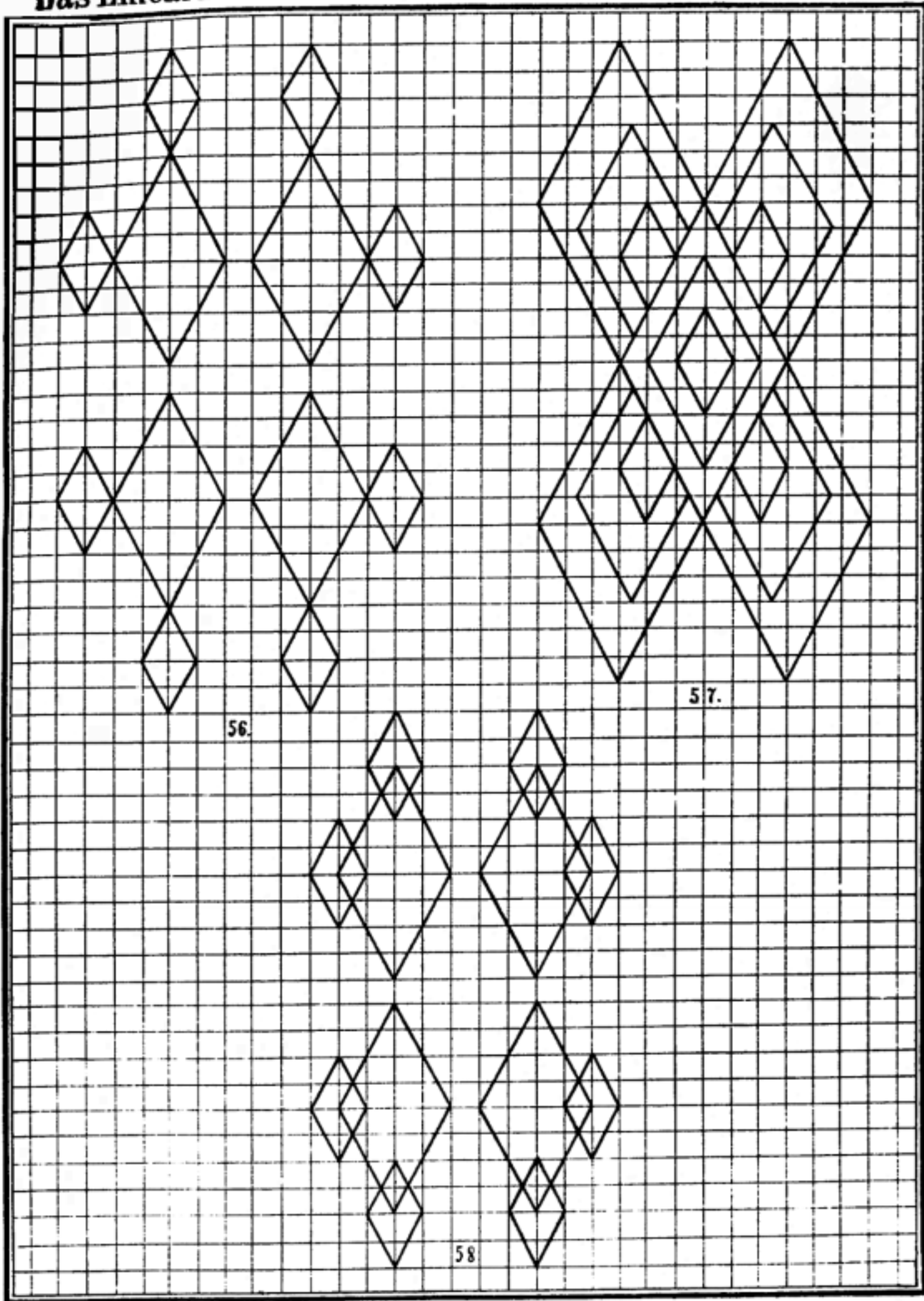

Schönheitsformen

Zur VL Gabe.

denen das Viereck zu grunde liegt.

Tafel XXVII.

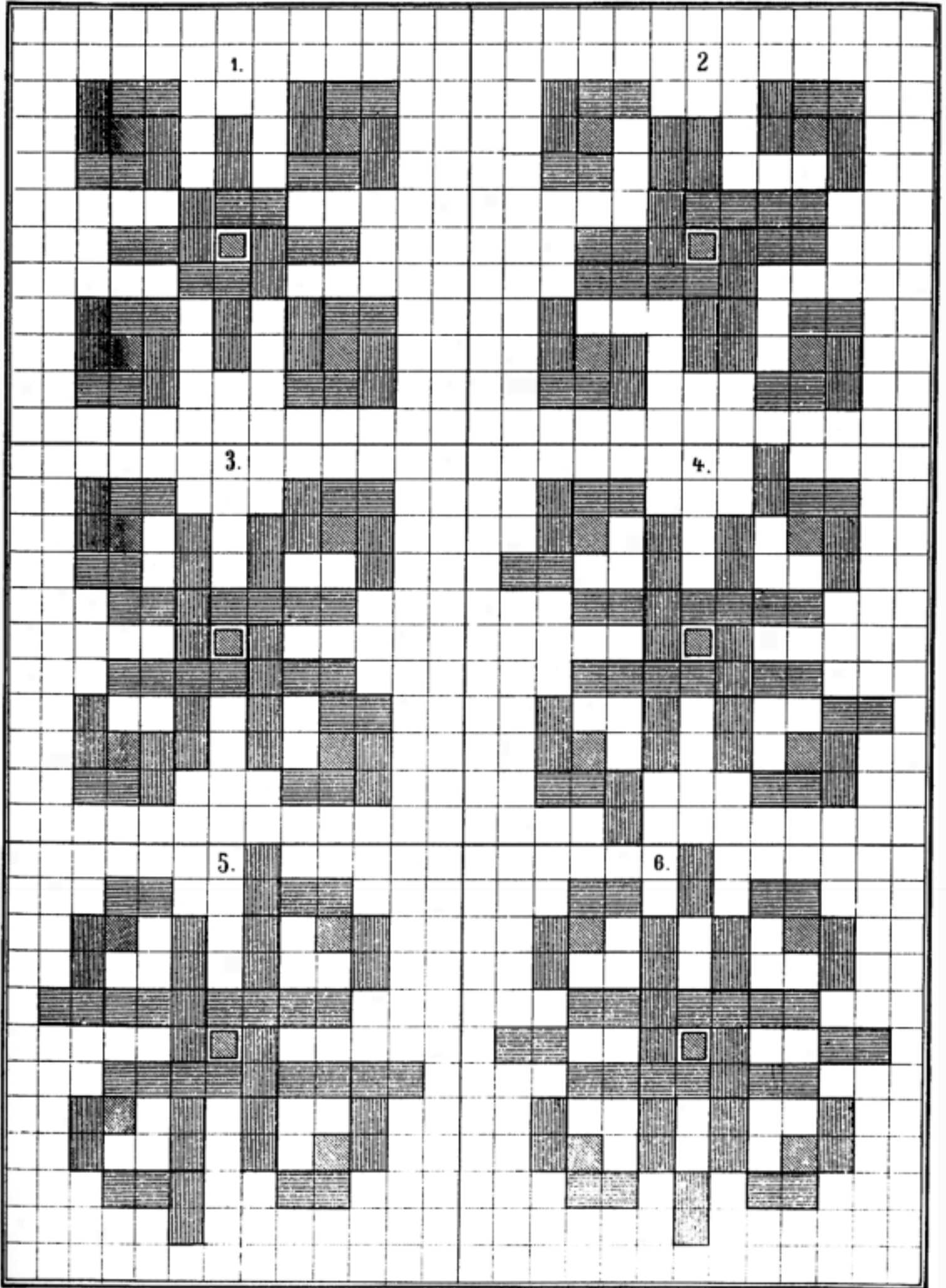

Zur VL Gabe.

Schönheitsformen

denen das Viereck zu grunde liegt.

Tafel XXVIII.

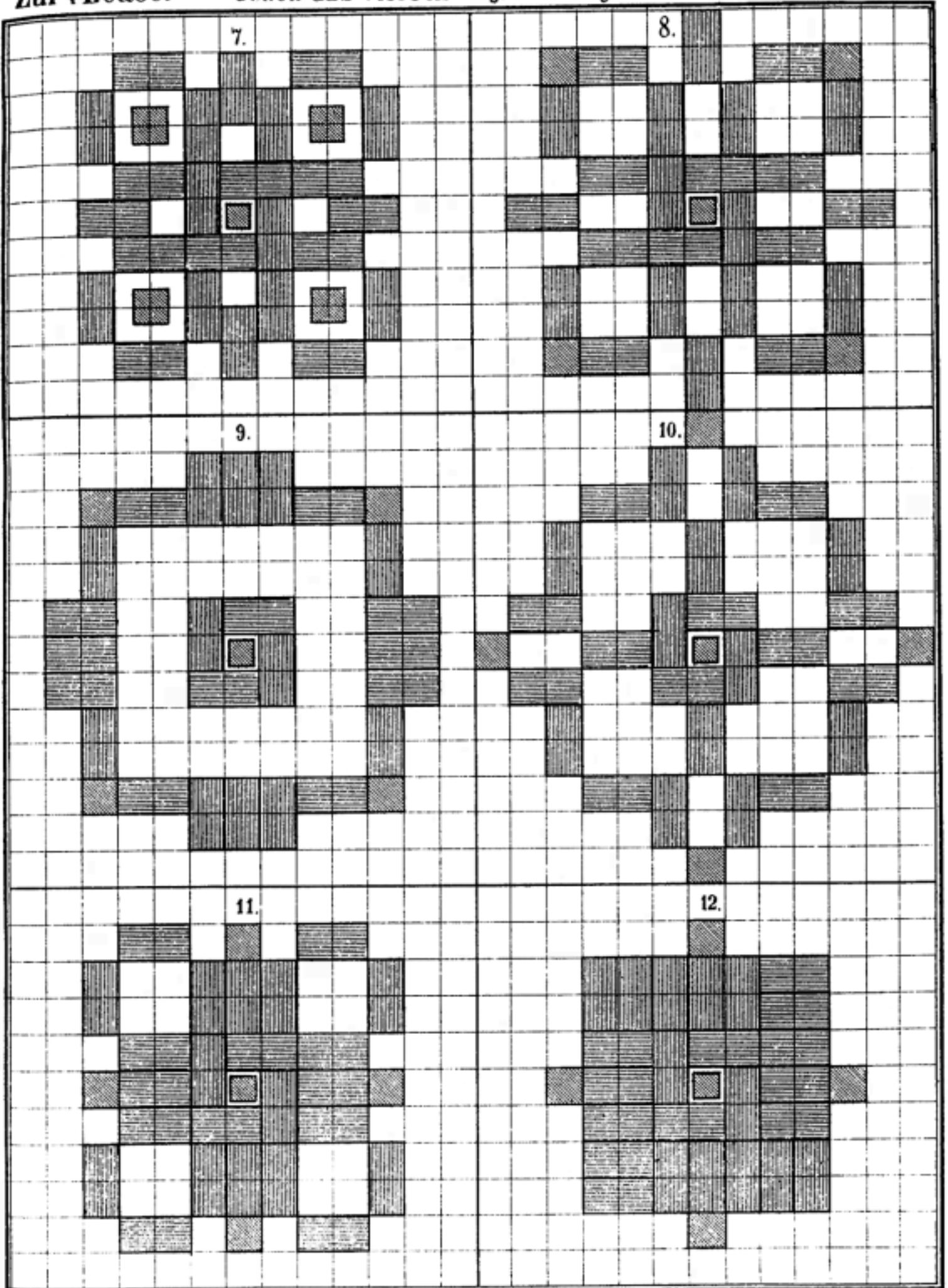

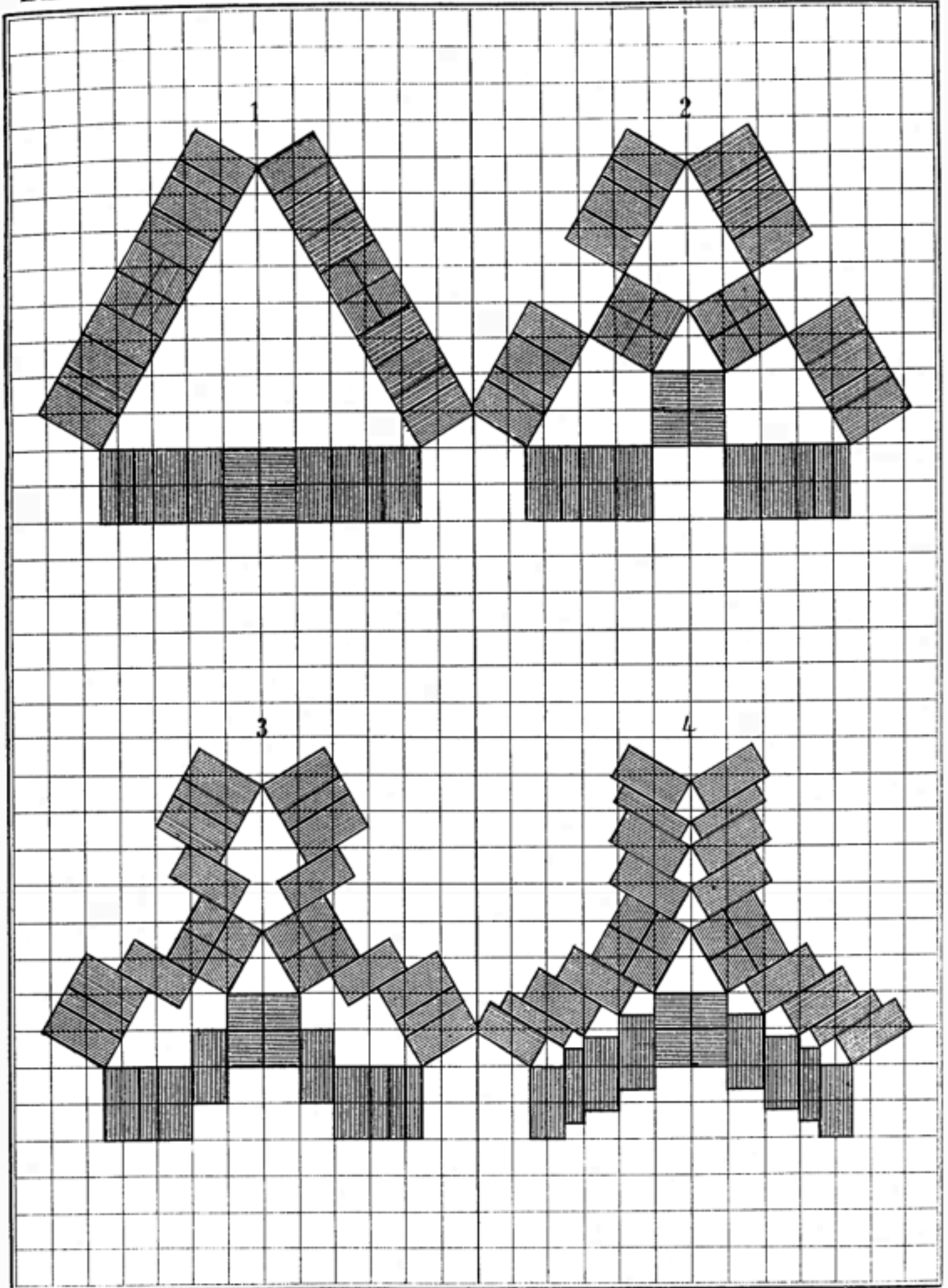

Erkenntnisformen.

A.

1 2 3 4

1 2 3 4 5 6 7 8 9 10

Lebensformen.

B.

1 2 3 4 5 6 7 8 9 10 11 12 13 14 15 16 17 18

Detailed description of the puzzle sheet: The sheet is a large grid with a dashed line forming a central area. At the top, four numbered shapes (1-4) are shown. Below them, the section 'Erkenntnisformen' is divided into two parts, A and B. Part A contains ten numbered shapes (1-10) made of squares. Part B contains eight numbered shapes (1-8) made of squares. Below these, the section 'Lebensformen' contains ten numbered shapes (9-18) made of squares and diamonds. The shapes are arranged in a roughly grid-like pattern across the page.

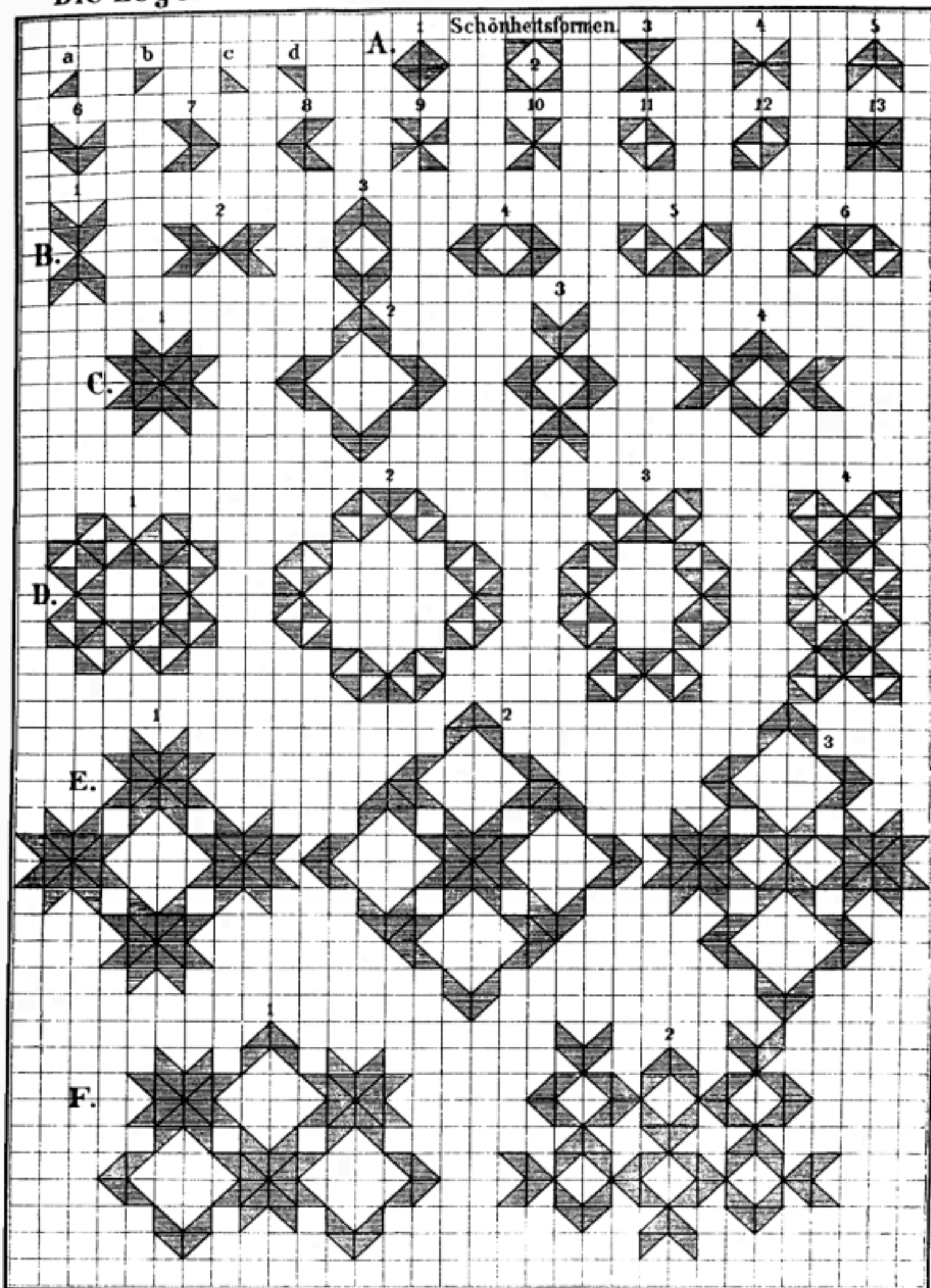

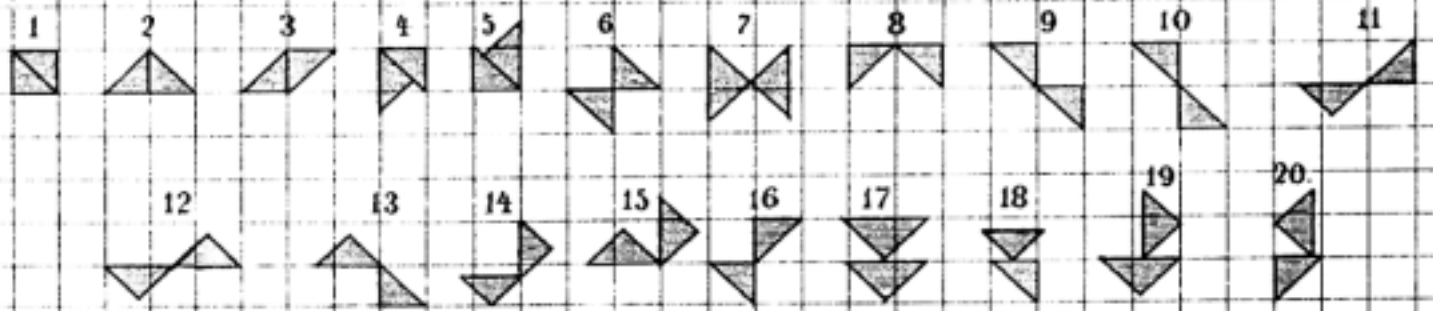

Erkenntnisformen.



Lebensformen.

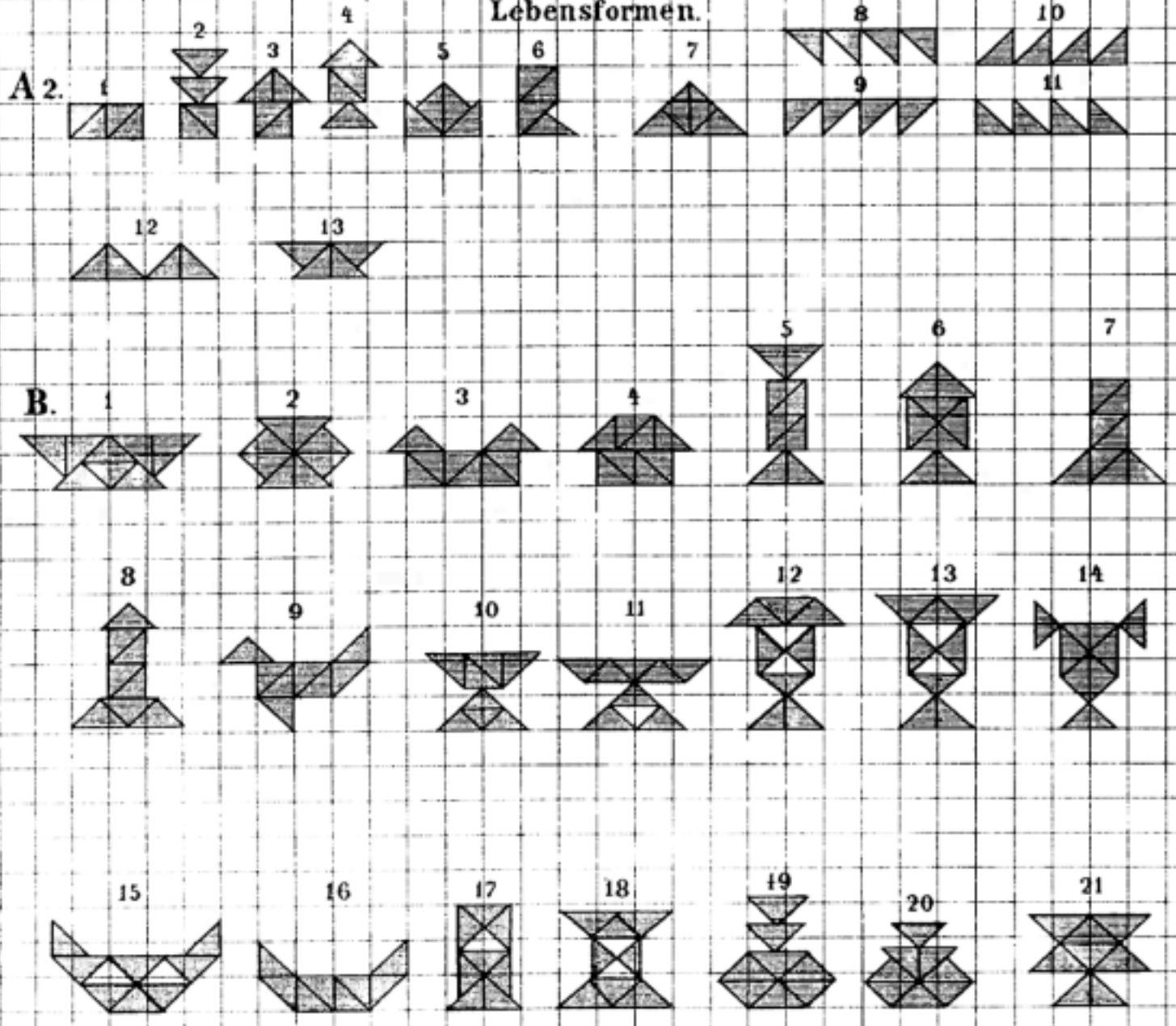

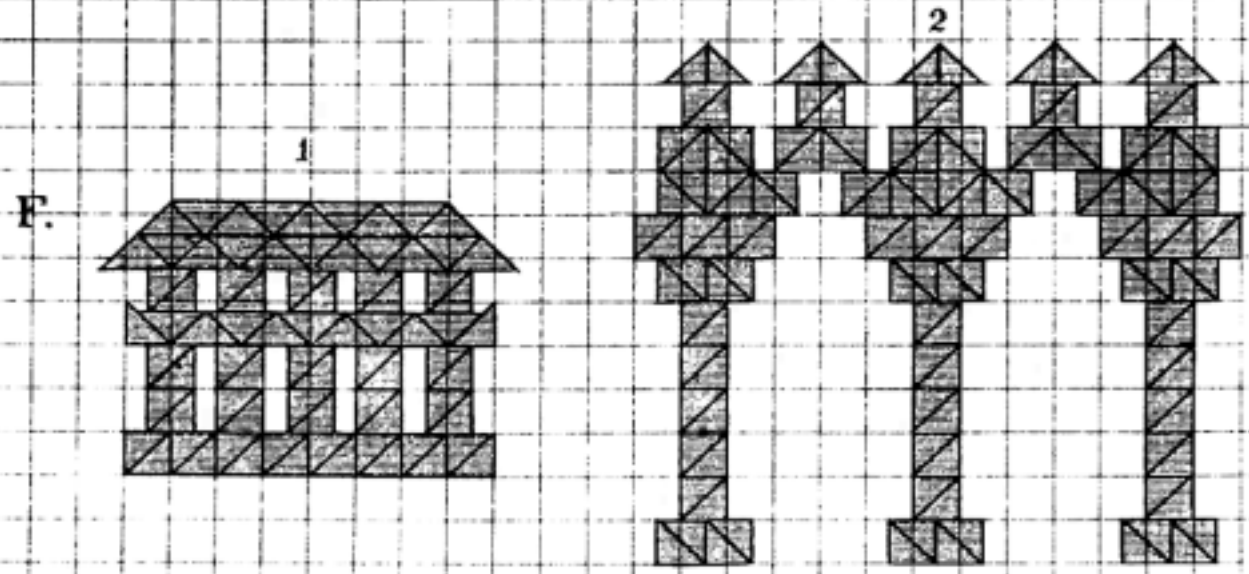
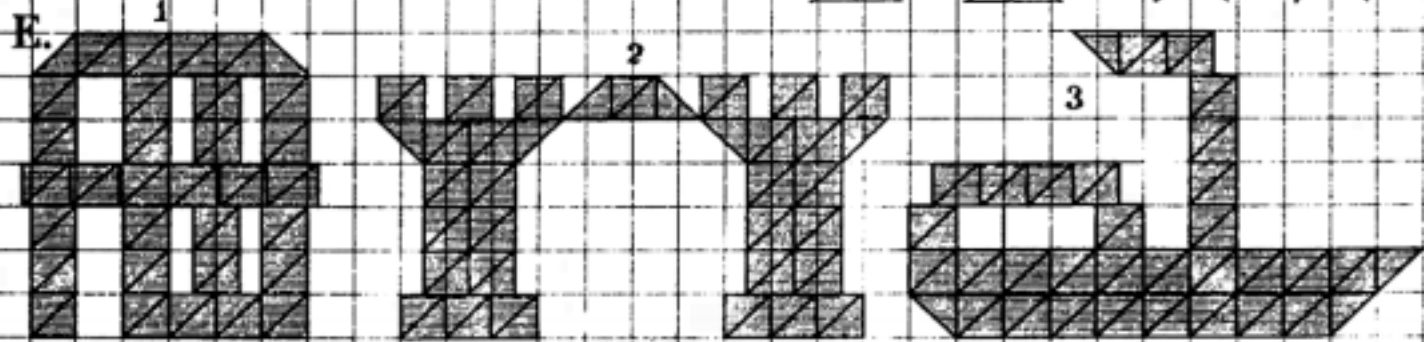
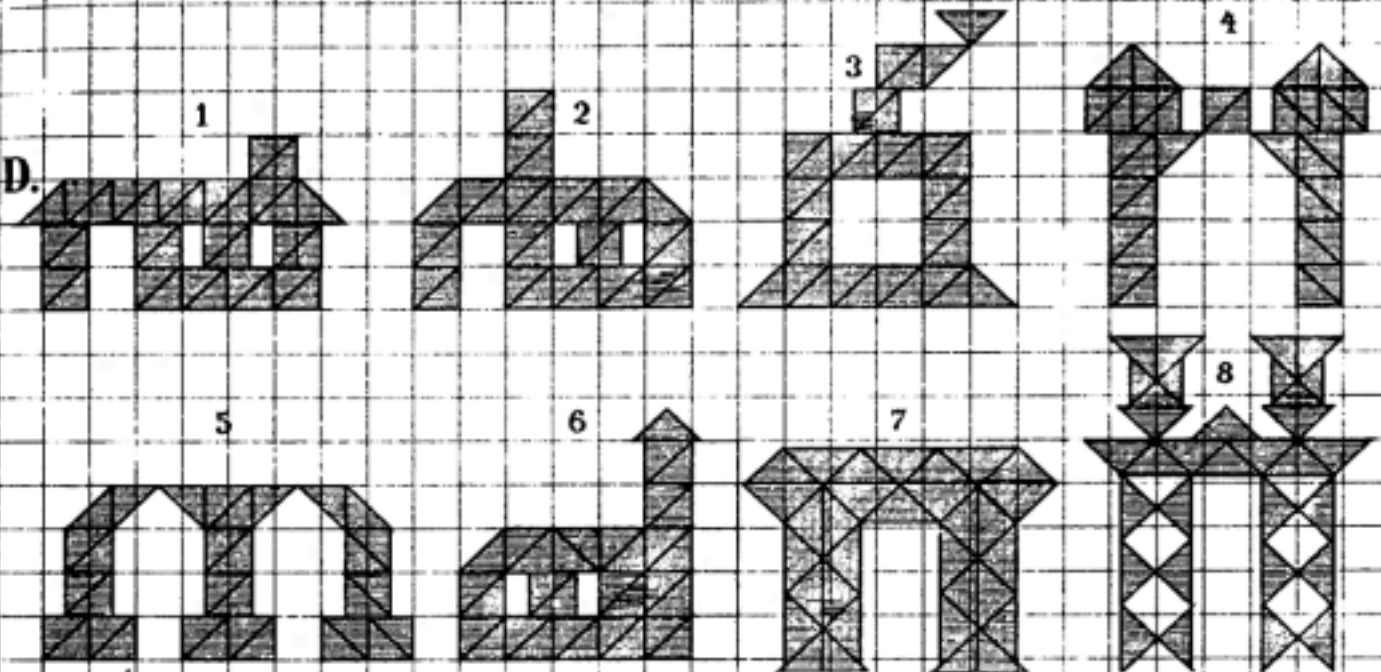
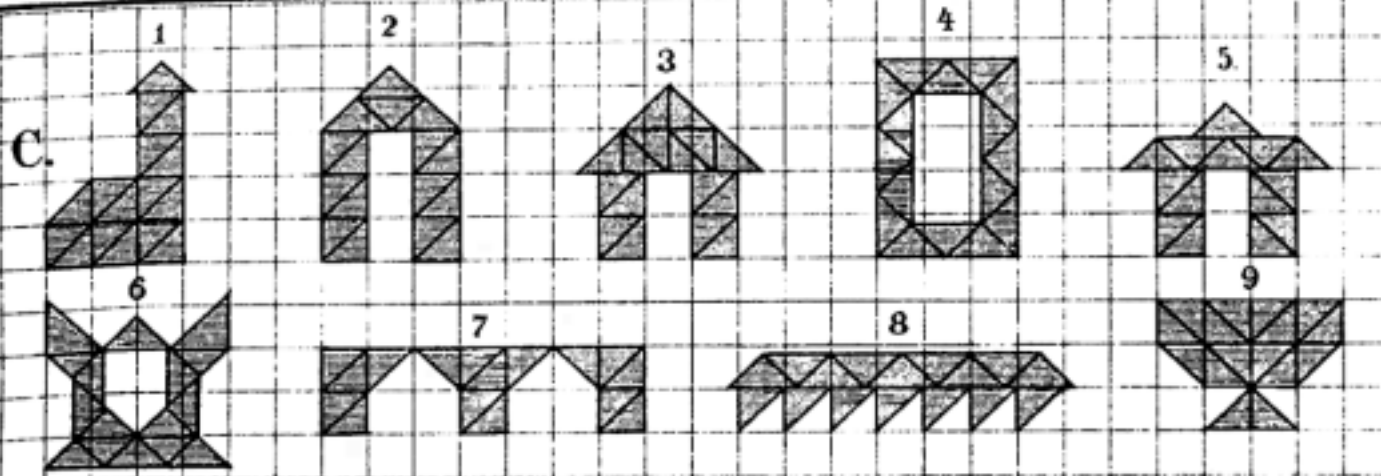



Erkenntnisformen.

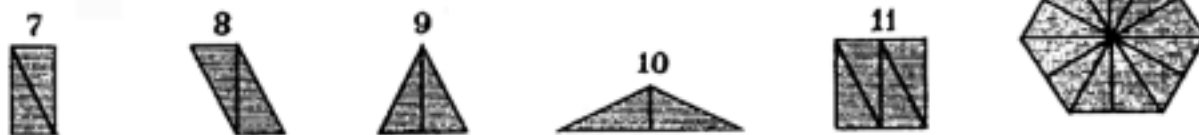

Schönheitsformen.

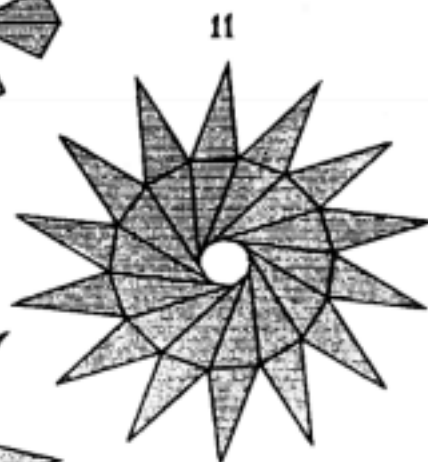
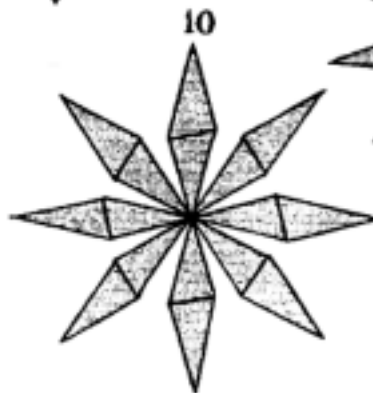
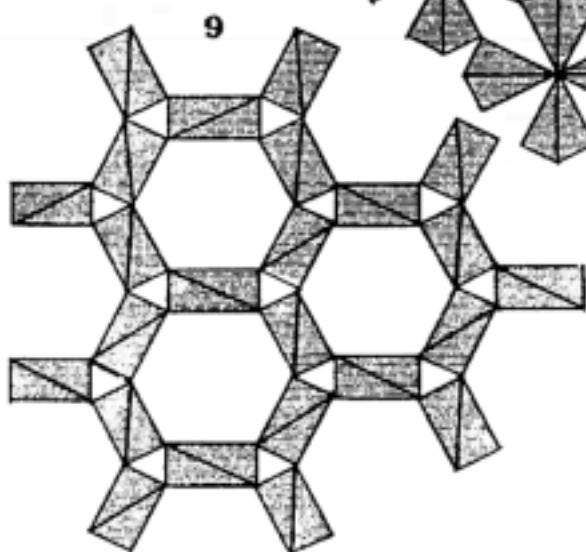
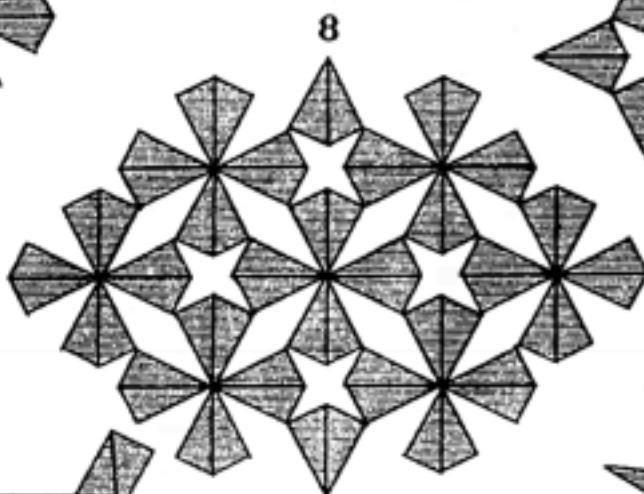
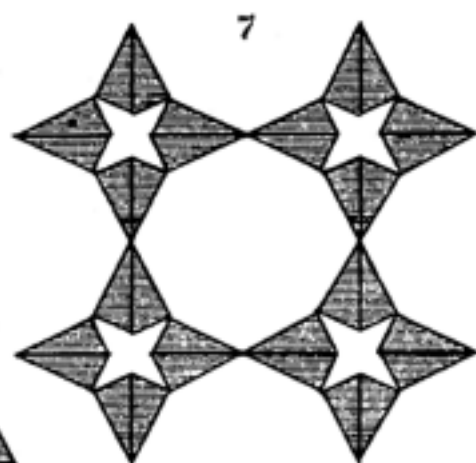
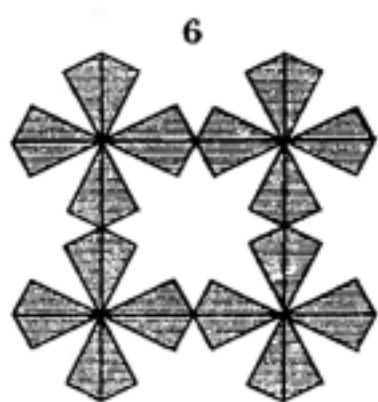
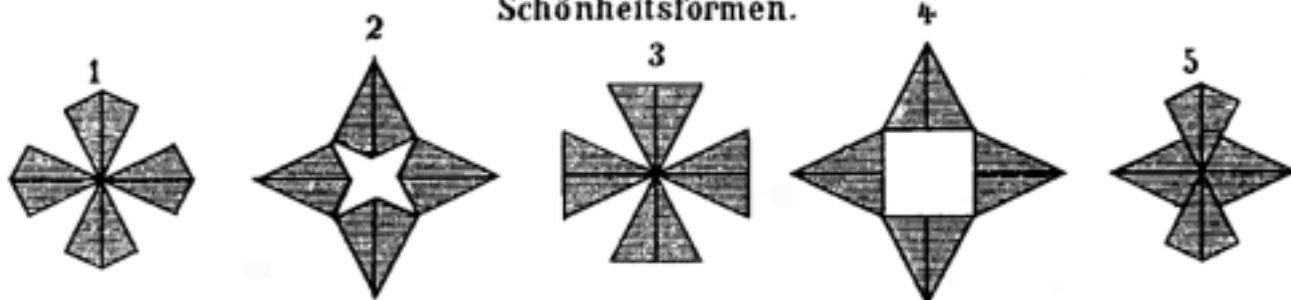

Lebensformen.

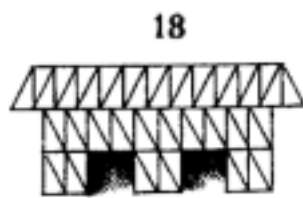
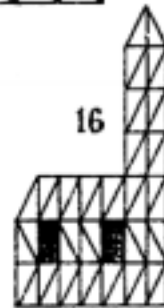
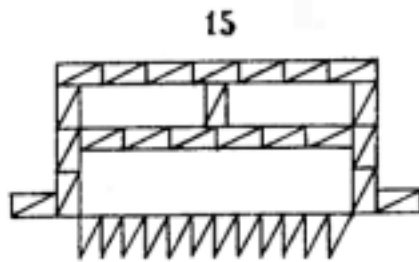
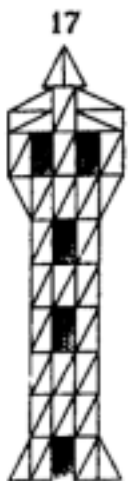
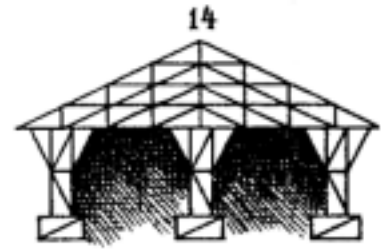
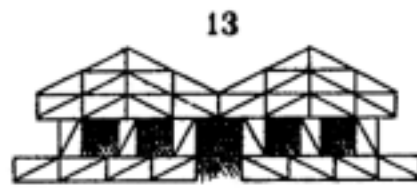
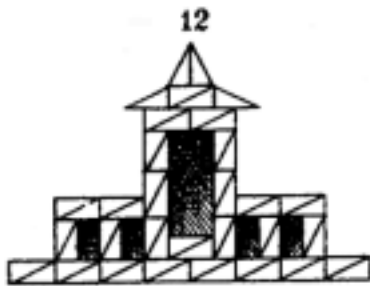
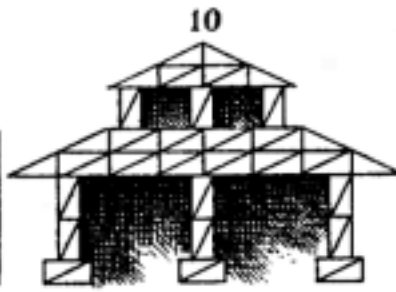
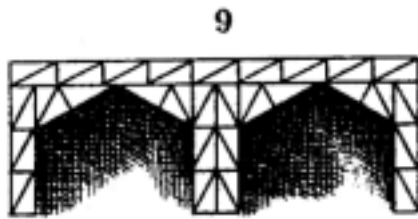
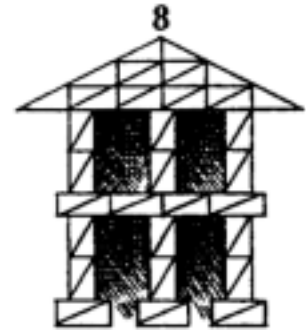
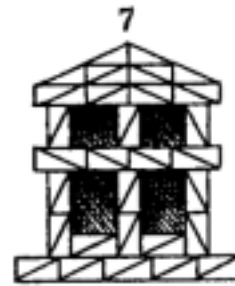
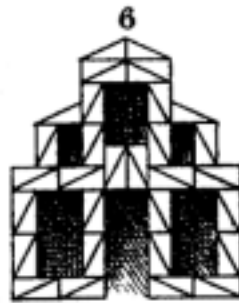
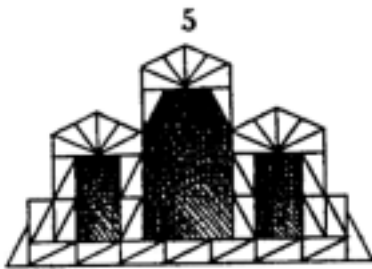
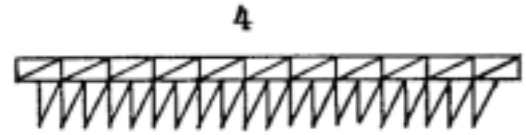
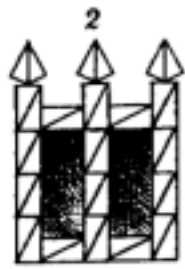

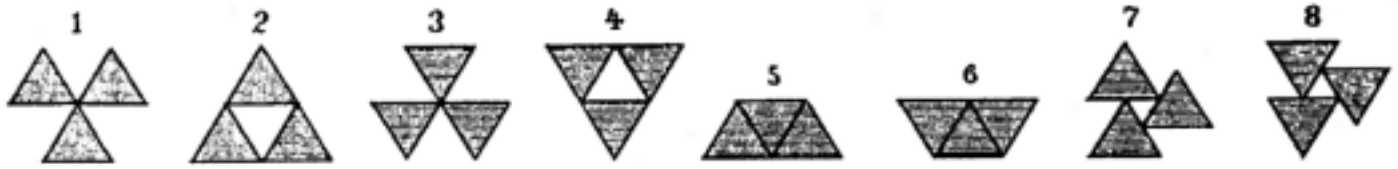

Erkenntnisformen. 3



Schönheitsformen.

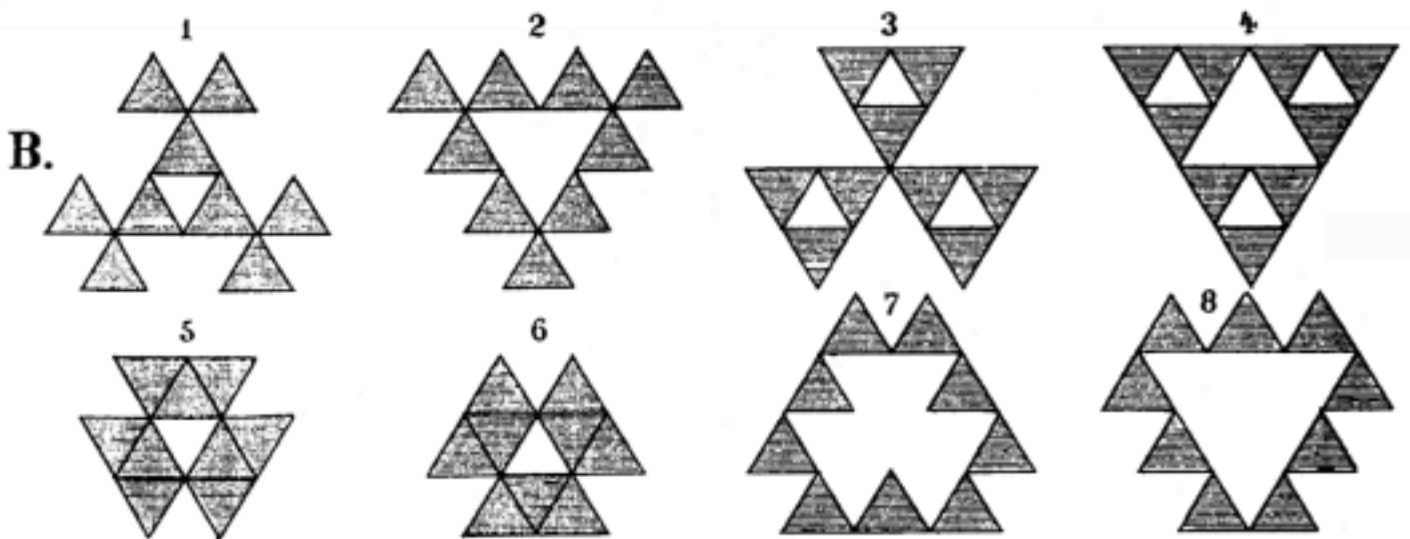
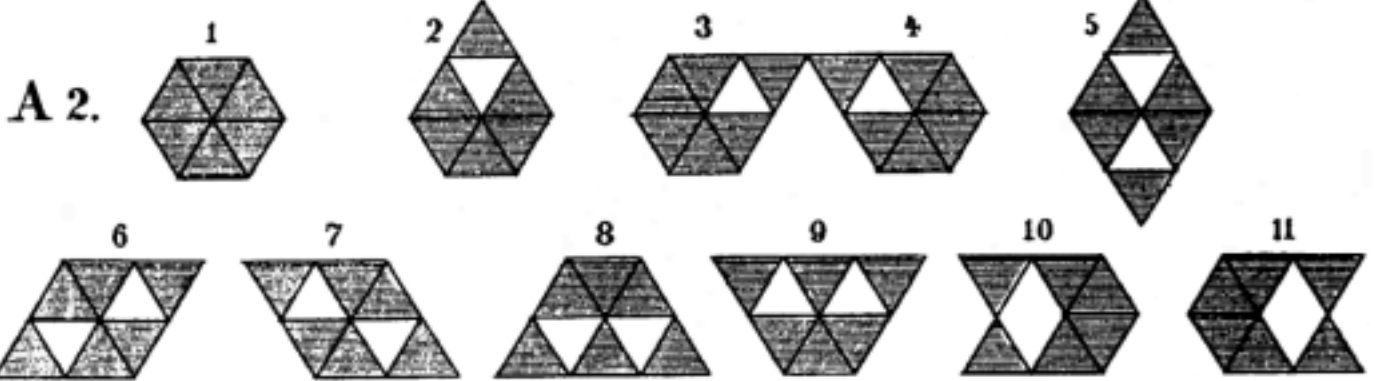
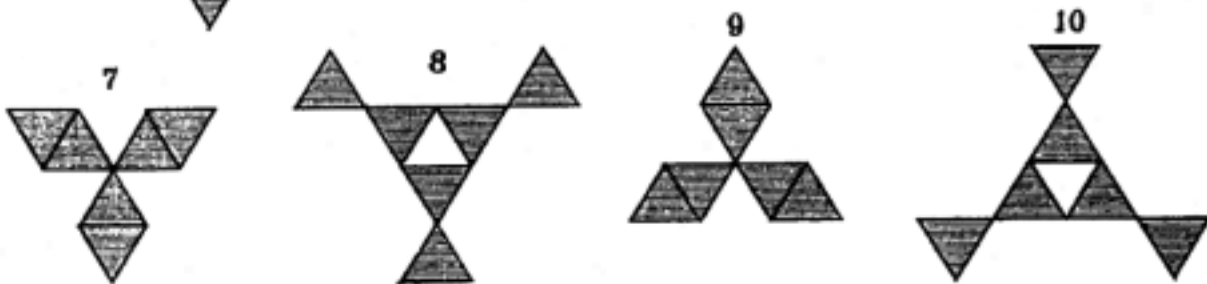
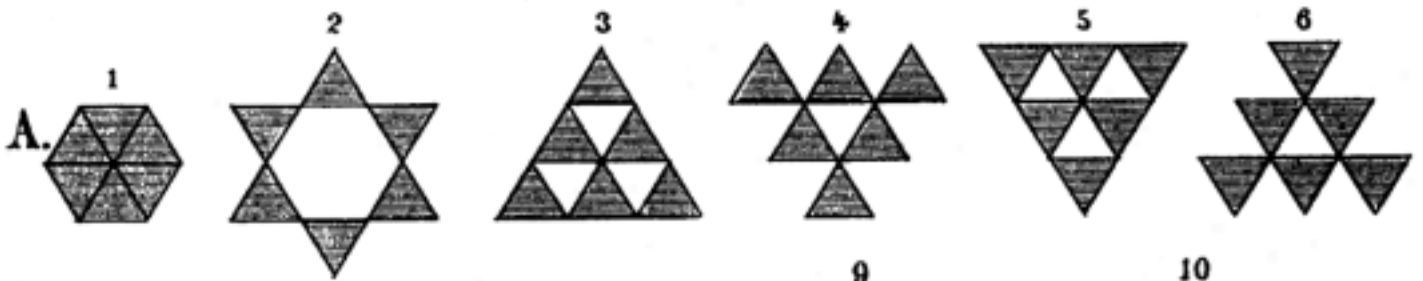

Lebensformen.

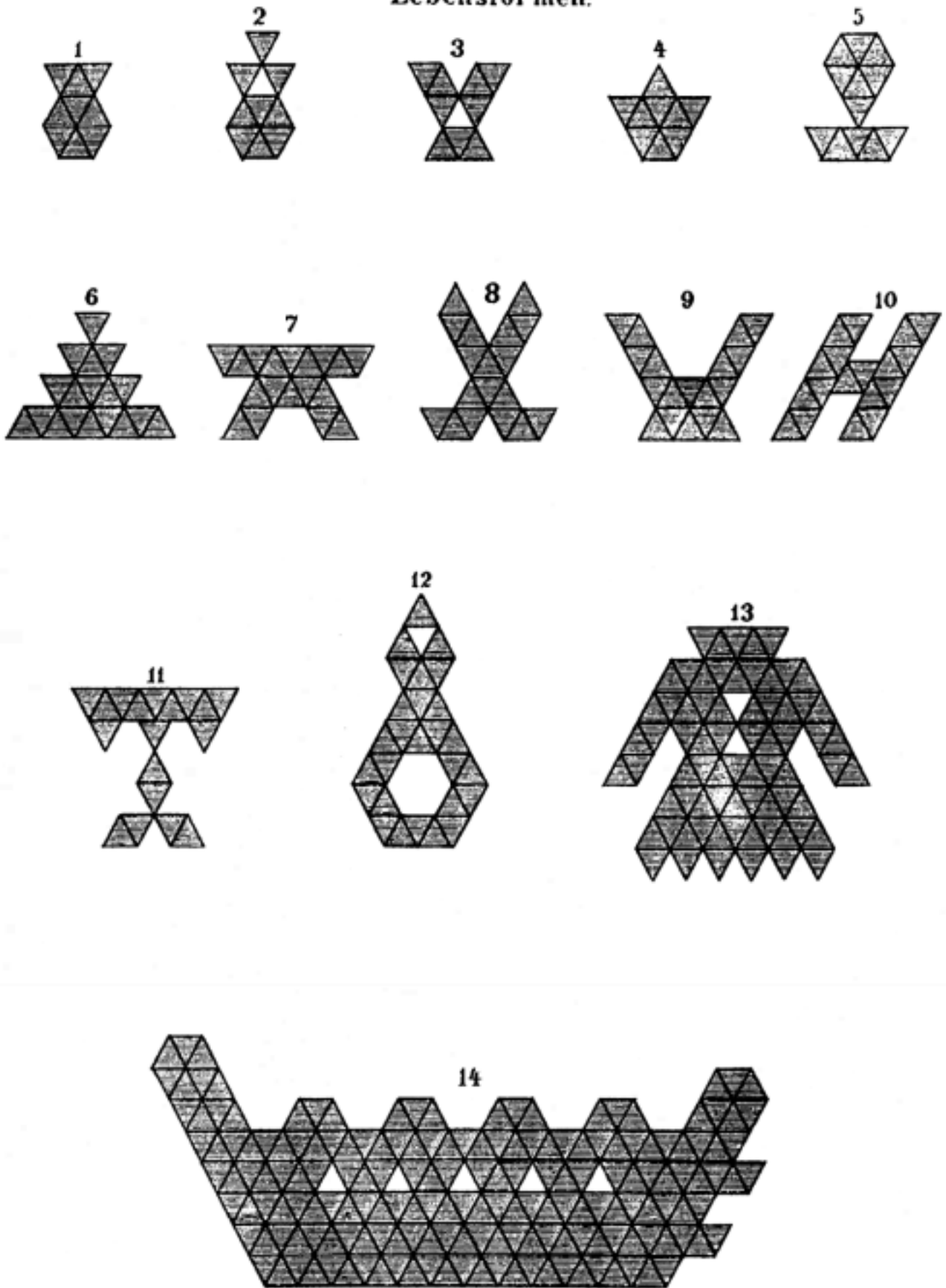

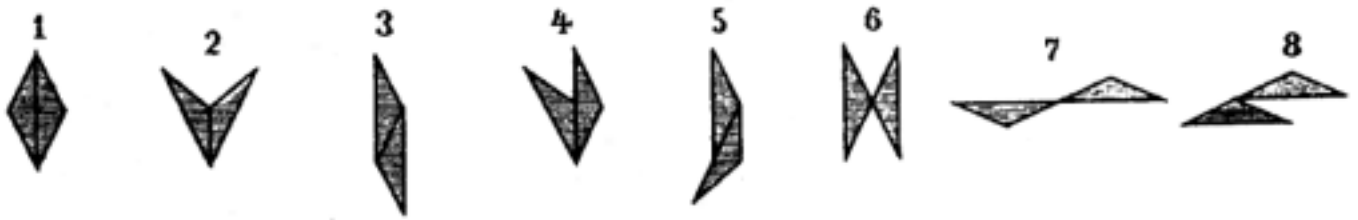

Erkenntnisformen.

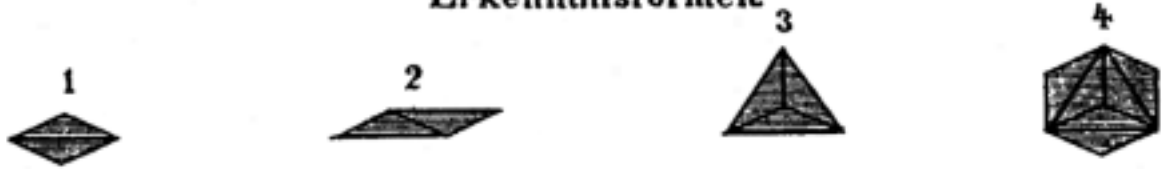



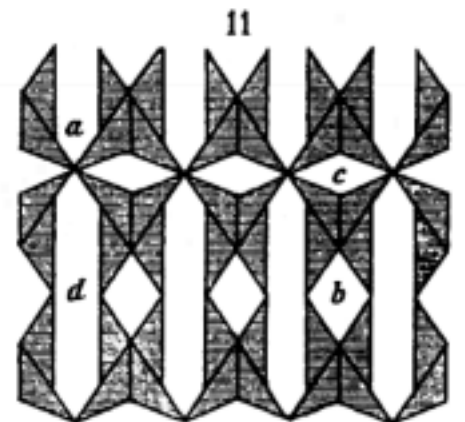
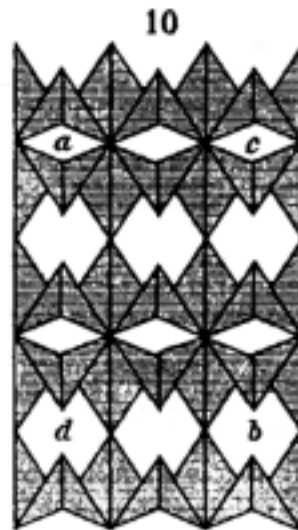
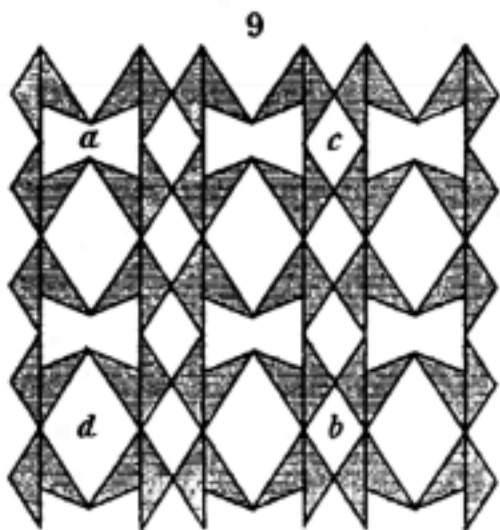
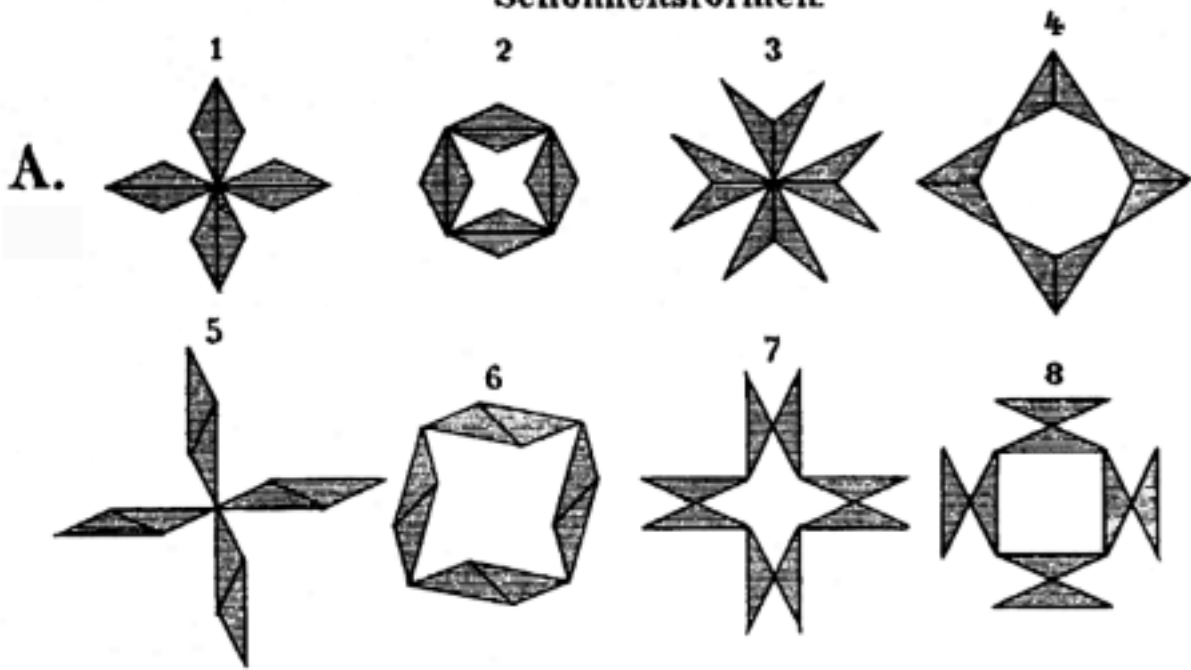



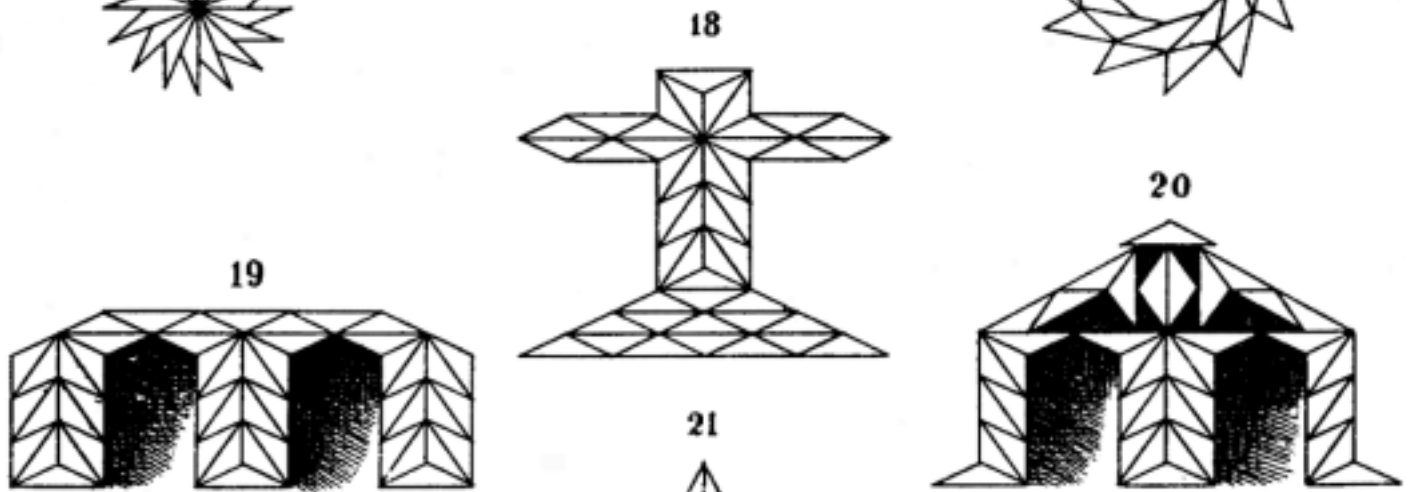
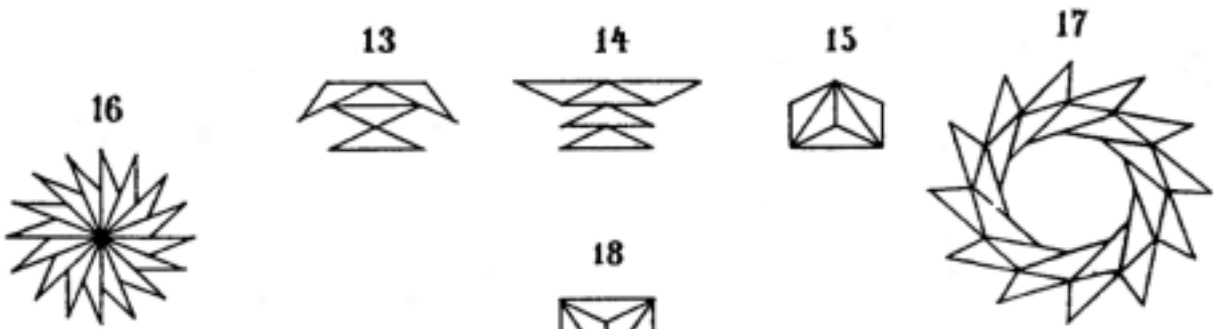
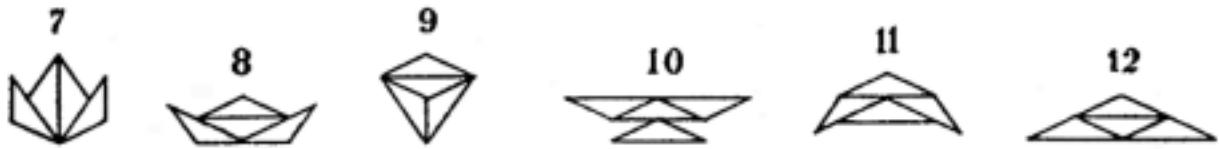
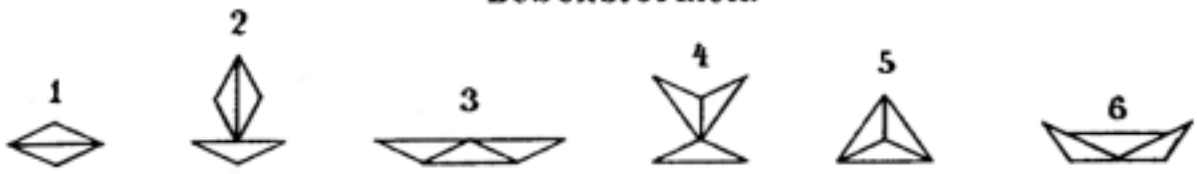



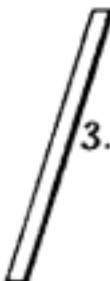

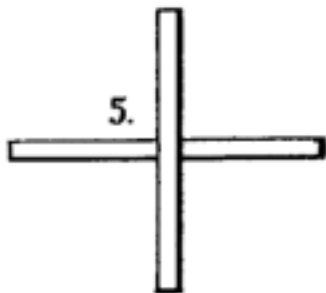
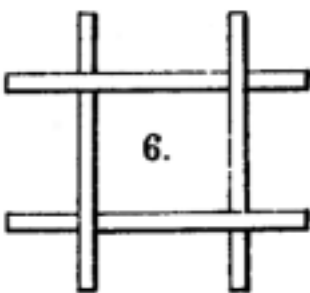
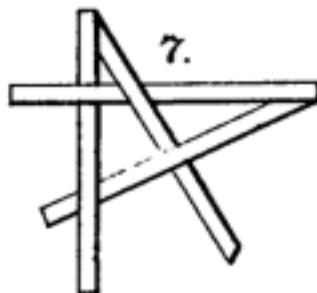
Schönheitsformen.



Lebensformen.

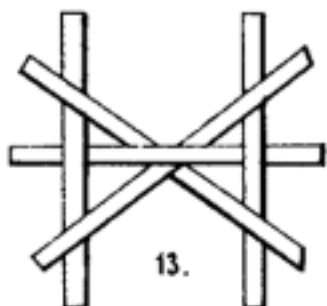

<p>1.</p>  <p>2.</p> 	<p>3.</p>  <p>4.</p> 	<p>5.</p> 
<p>6.</p> 	<p>7.</p> 	<p>8.</p> 
<p>9.</p> 	<p>10.</p> 	<p>11.</p> 
<p>12.</p> 	<p>13.</p> 	<p>14.</p> 

Figuren aus 4 Stäbchen.

Aus 2 Stäbchen.

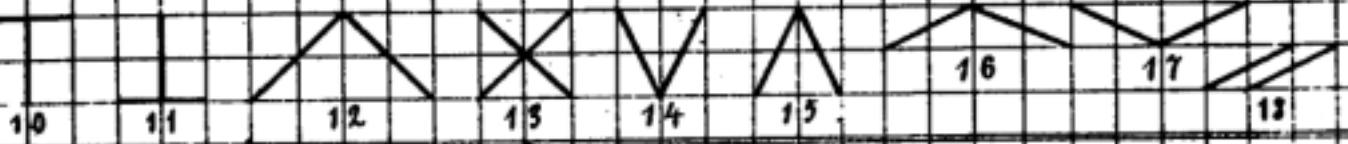
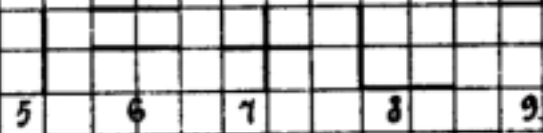
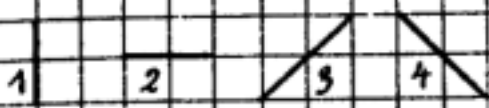

Aus 3 Stäbchen

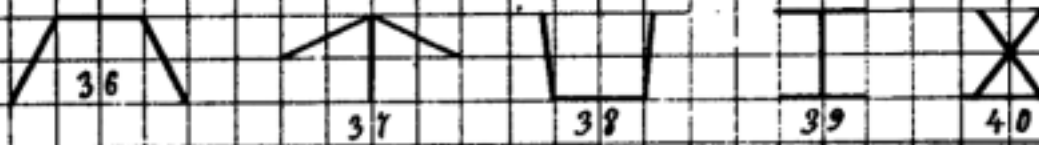
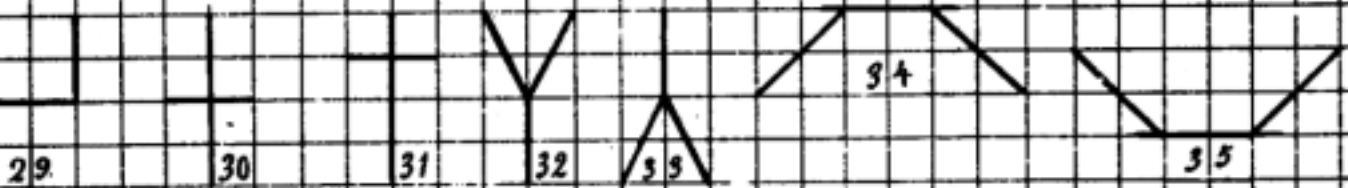
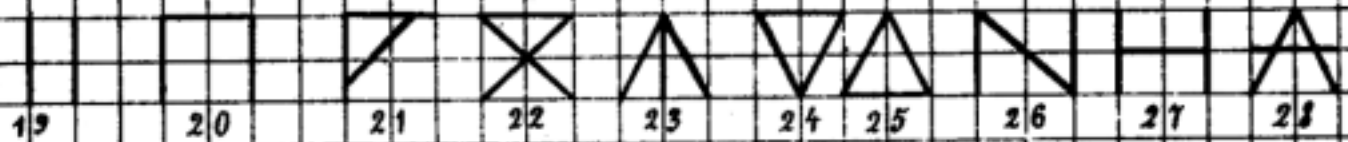

Aus 4 Stäbchen

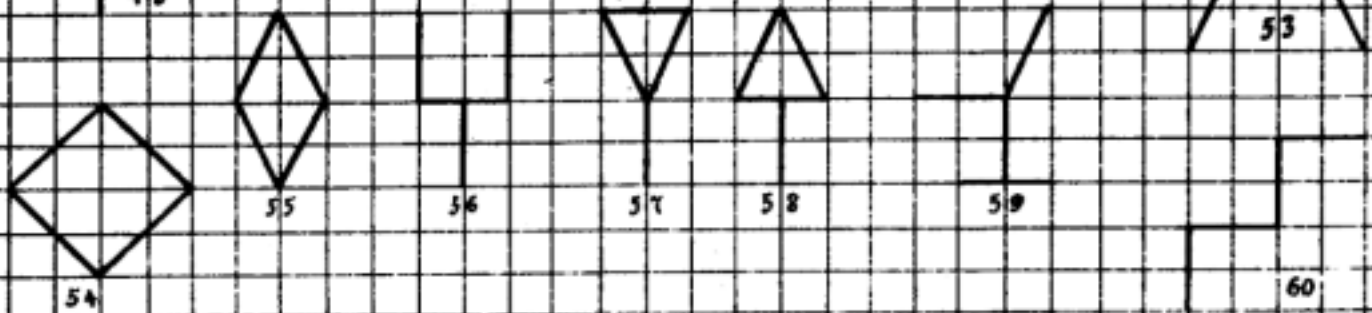
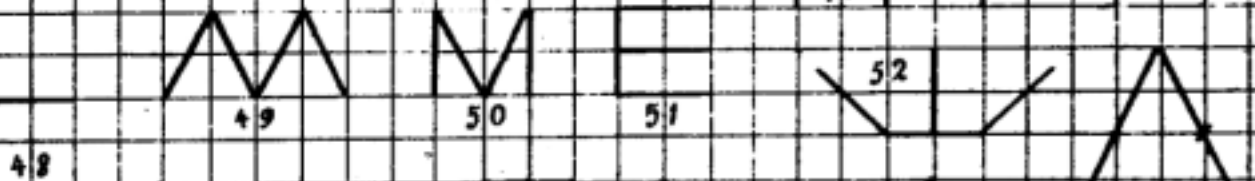
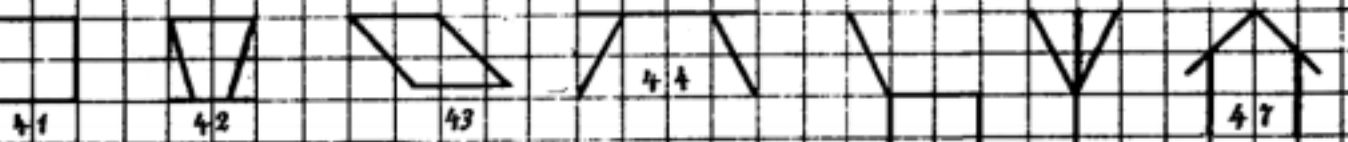

Figuren aus 5 Stäbchen.



61.

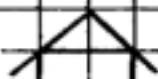

62.



63.

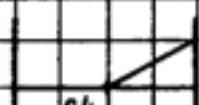

64.



65.



66.

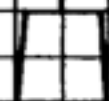

67.



68.



69.



70.



71.

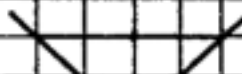

72.



73.



74.

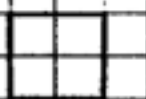

75.



76.

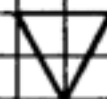

77.

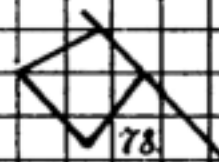

78.

Aus 6 Stäbchen.

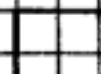

79.



80.

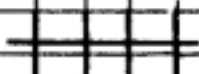

81.

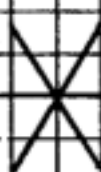

82.



83.

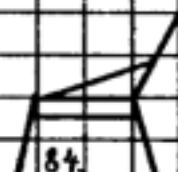

84.



85.



86.

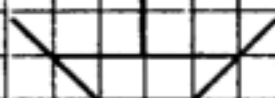

87.

Aus 7 Stäbchen.



88.

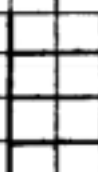

89.

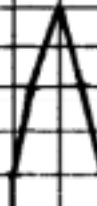

90.

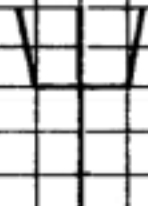

91.

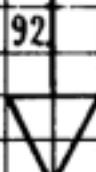

92.



93.

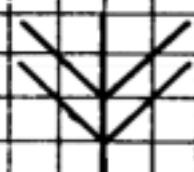

94.

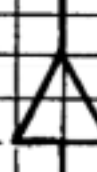

95.

Aus 8 Stäbchen.

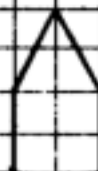

96.



97.



98.



99.

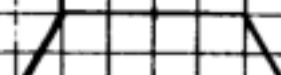

100.

Aus beliebig vielen Stäbchen.

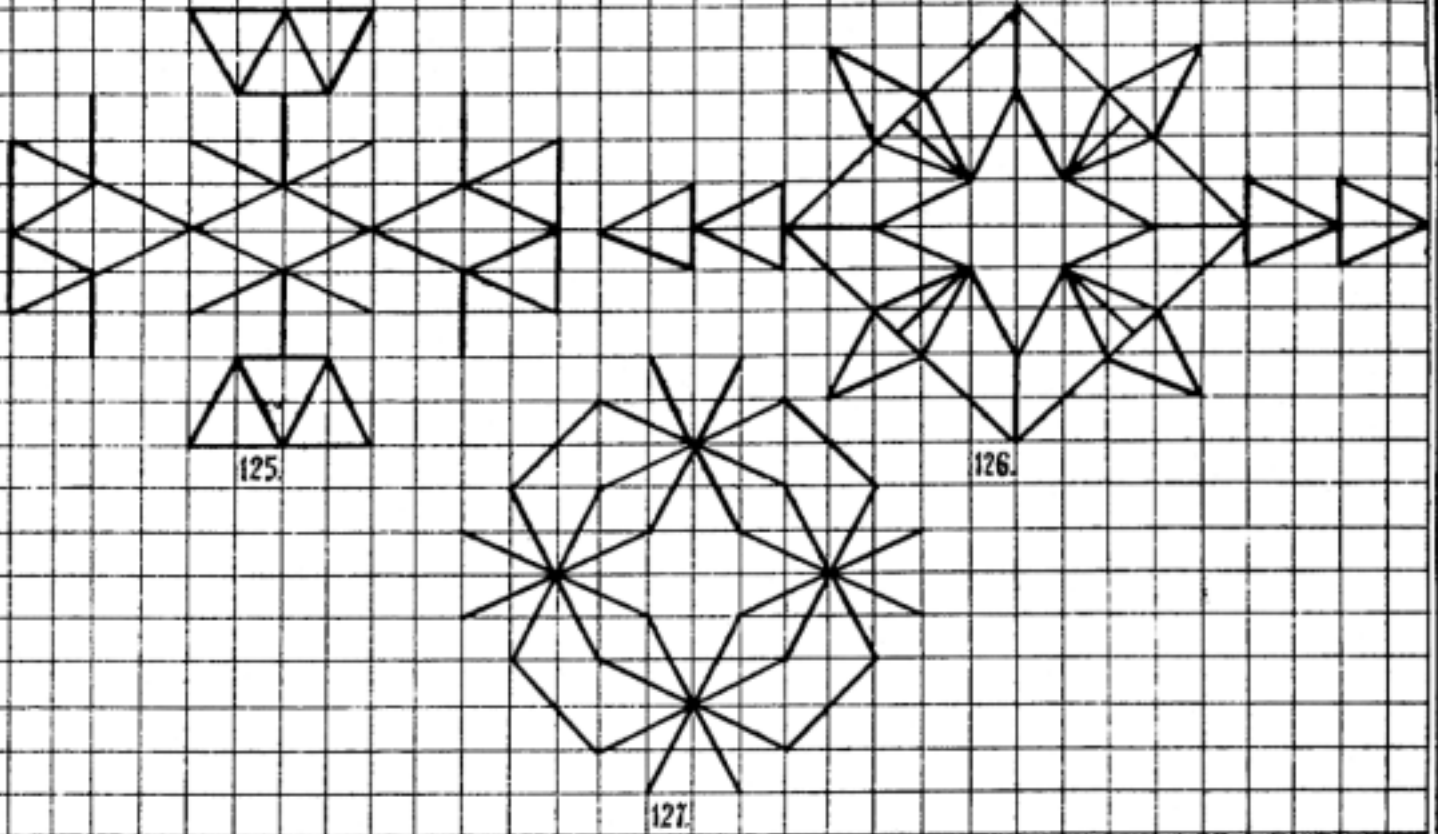

Erfindungen von Kindern aus dem Kindergarten.

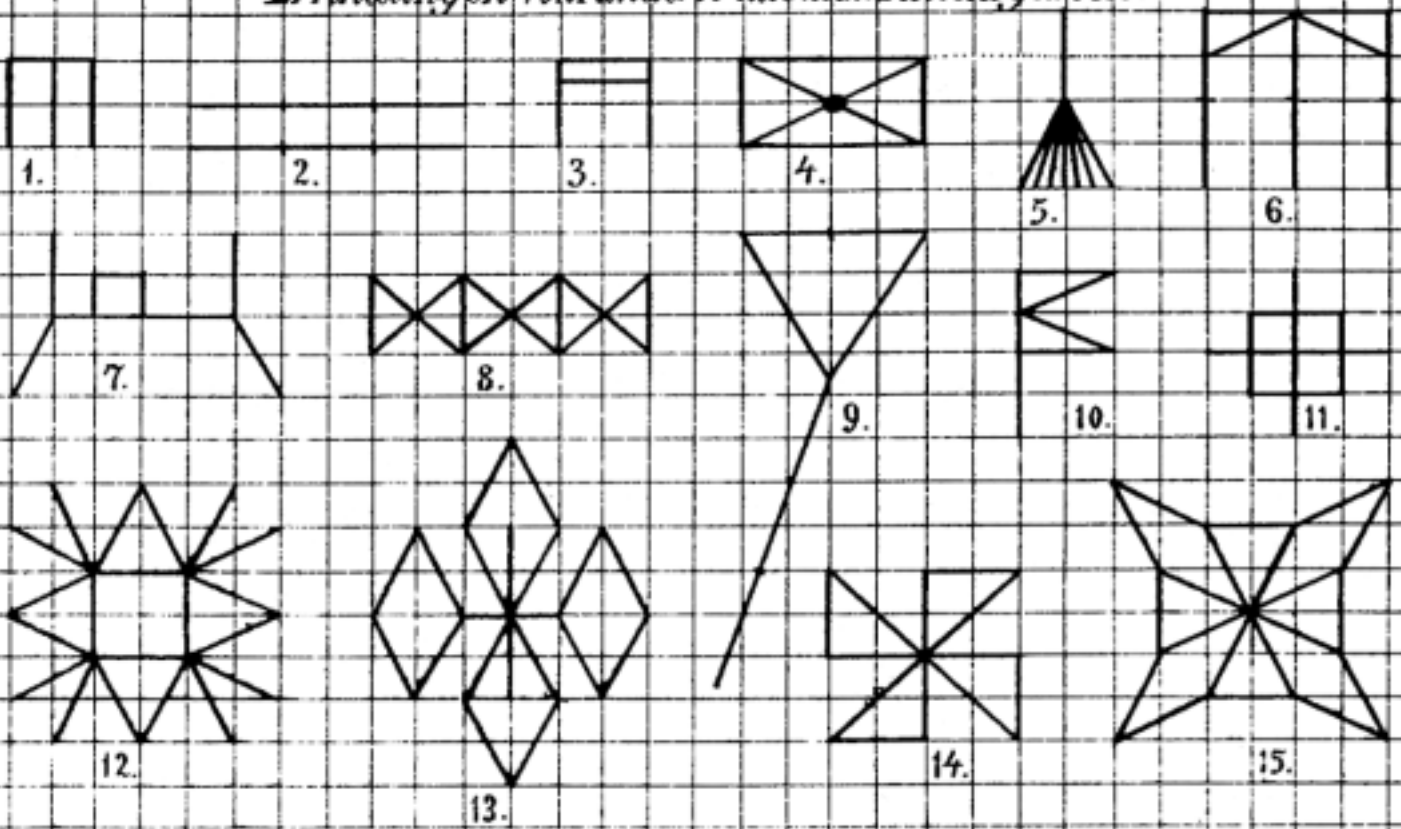

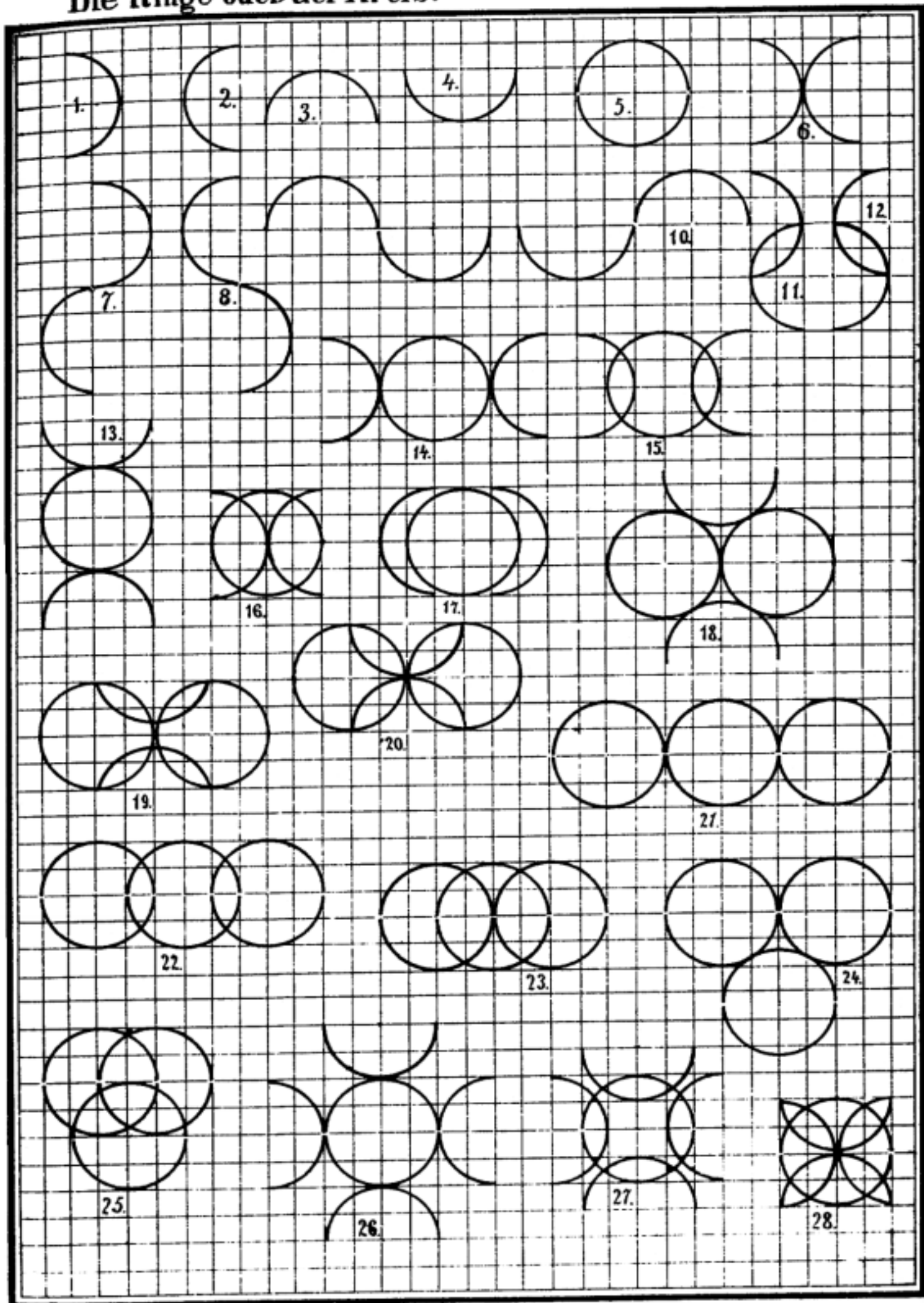

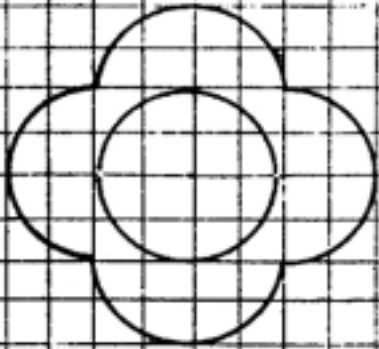

29.

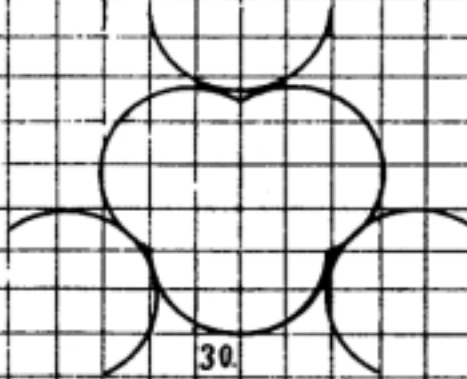

30.

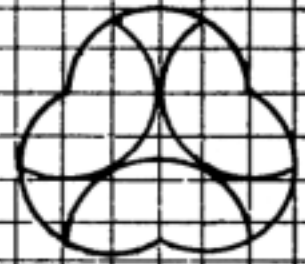

31.

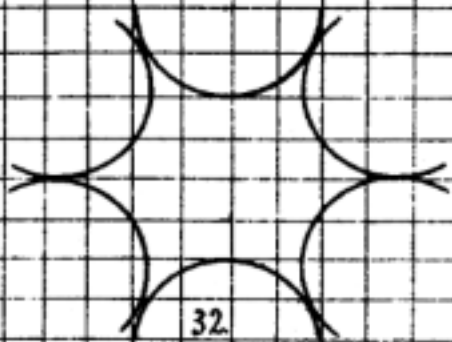

32.

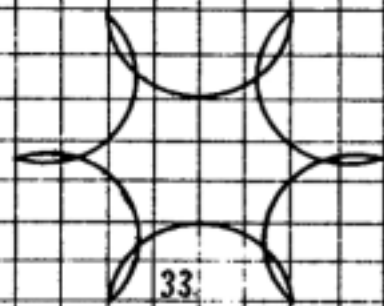

33.

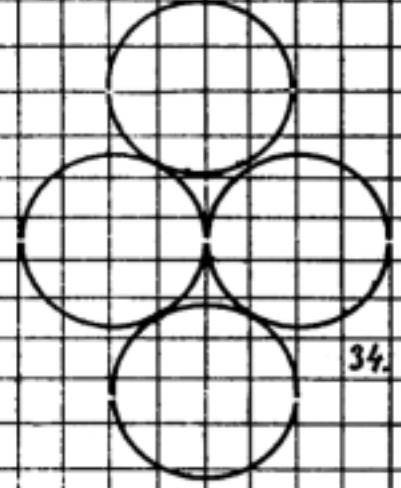

34.

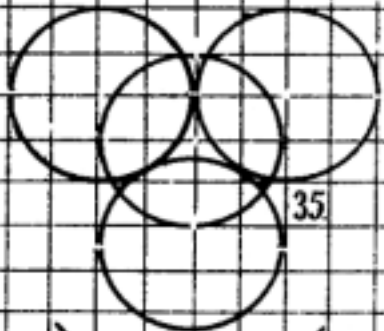

35.

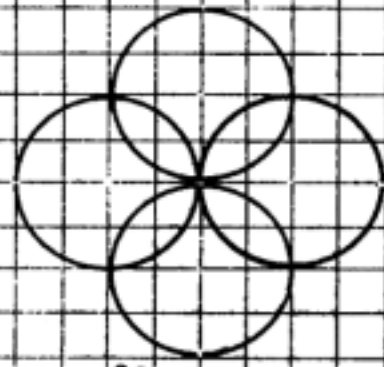

36.

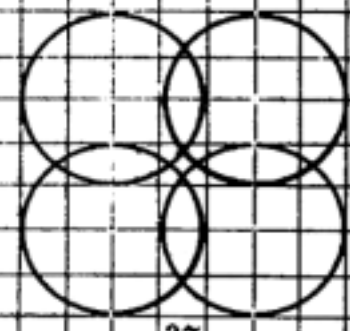

37.

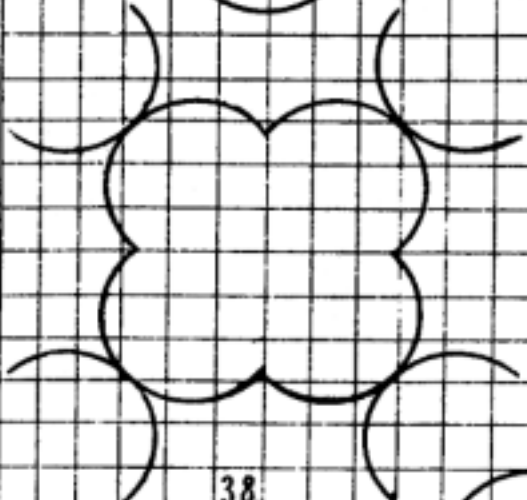

38.

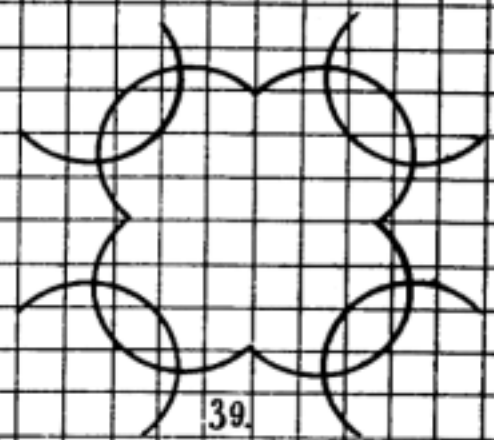

39.

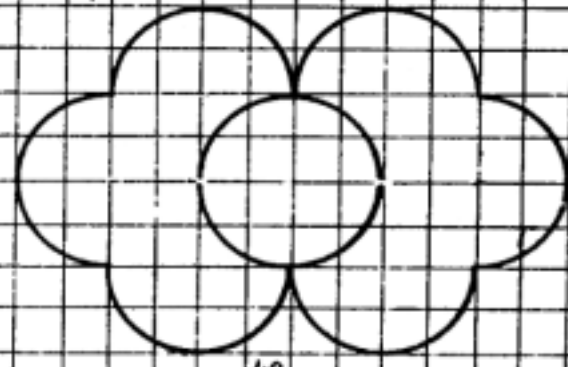

40.

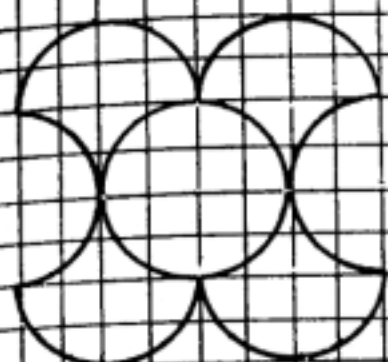

41.

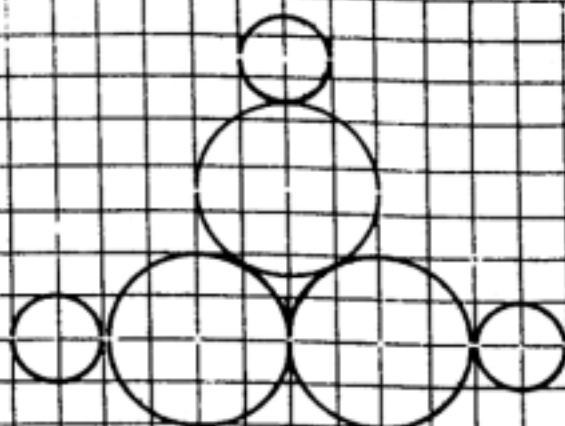

42.

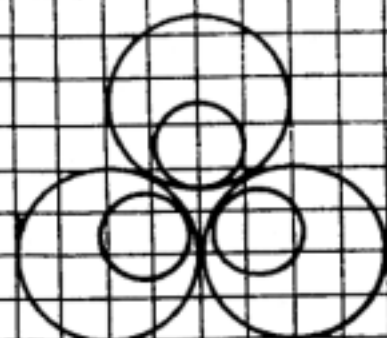

43.

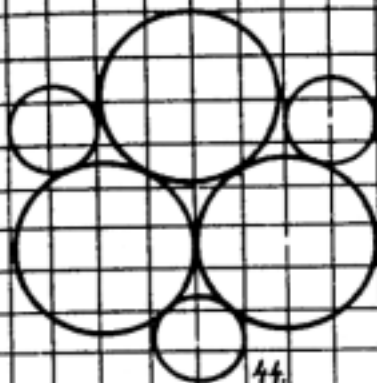

44.

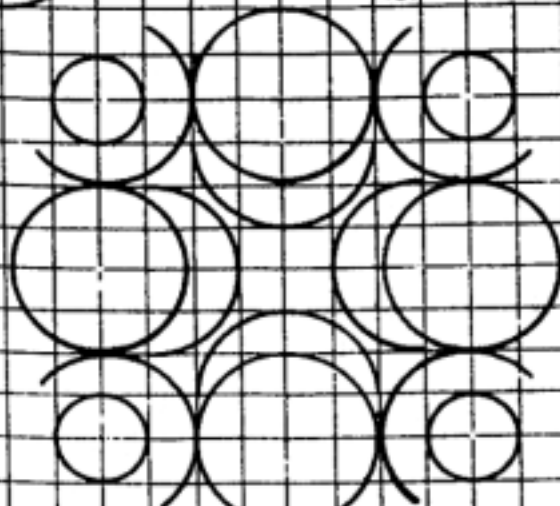

45.

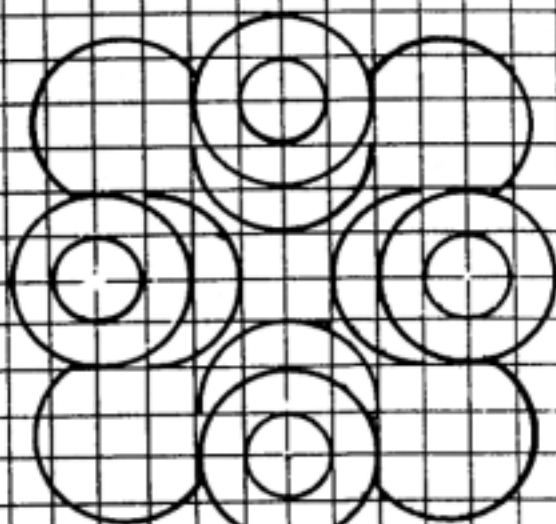

46.

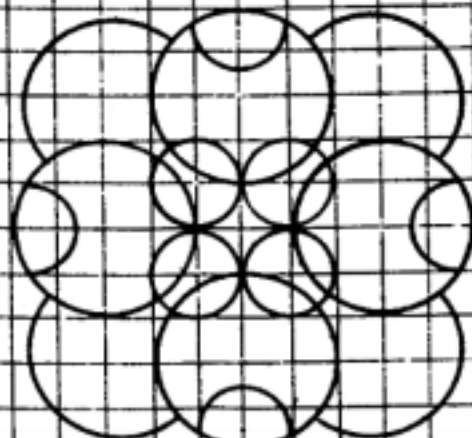

47.

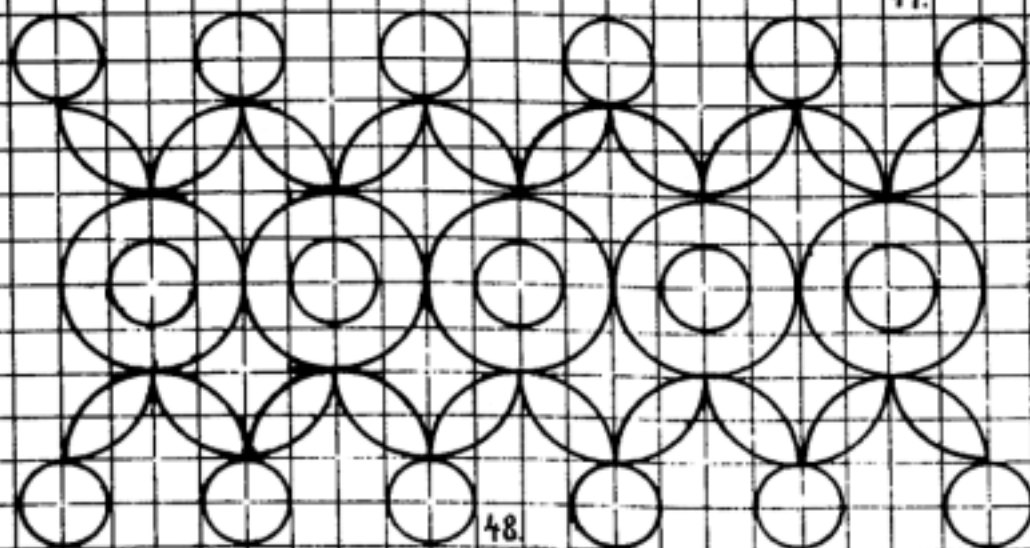

48.

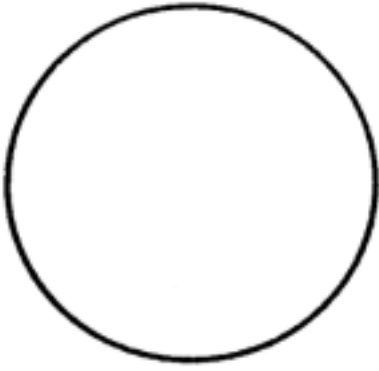

1.



2.

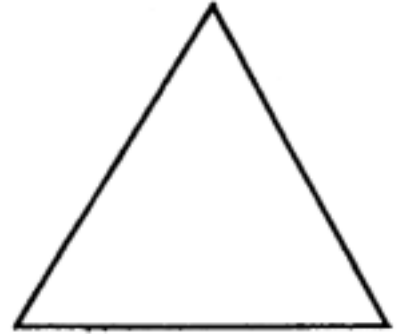

3.

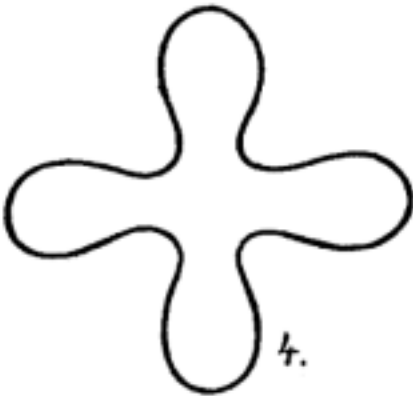

4.



5.



6.

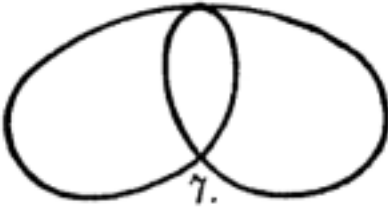

7.

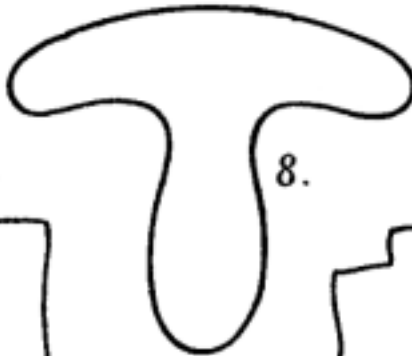

8.

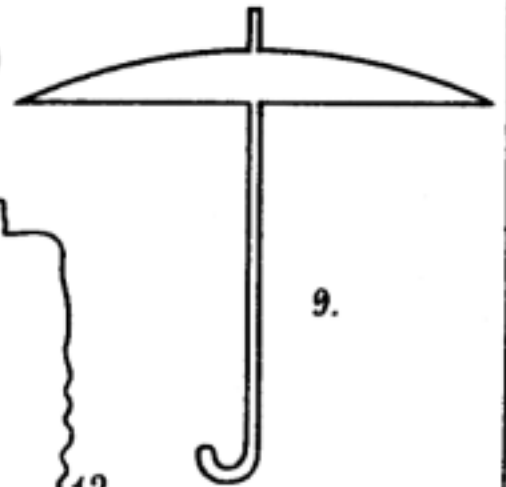

9.



15.



11.

12.

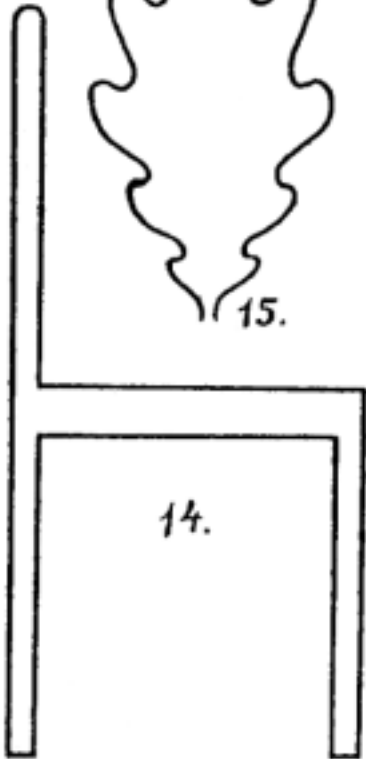

14.

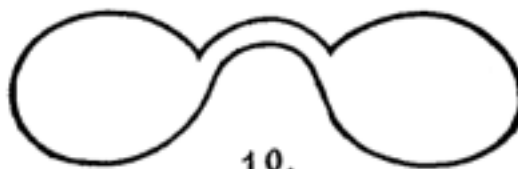

10.

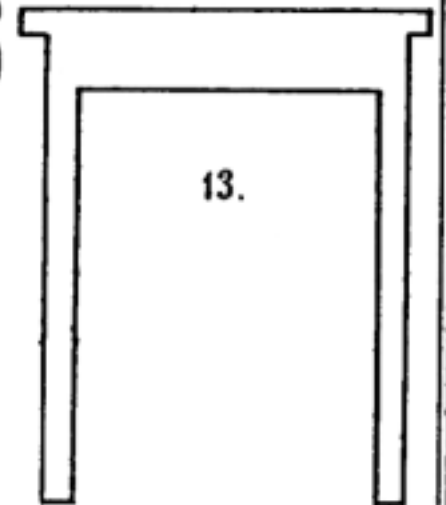

13.

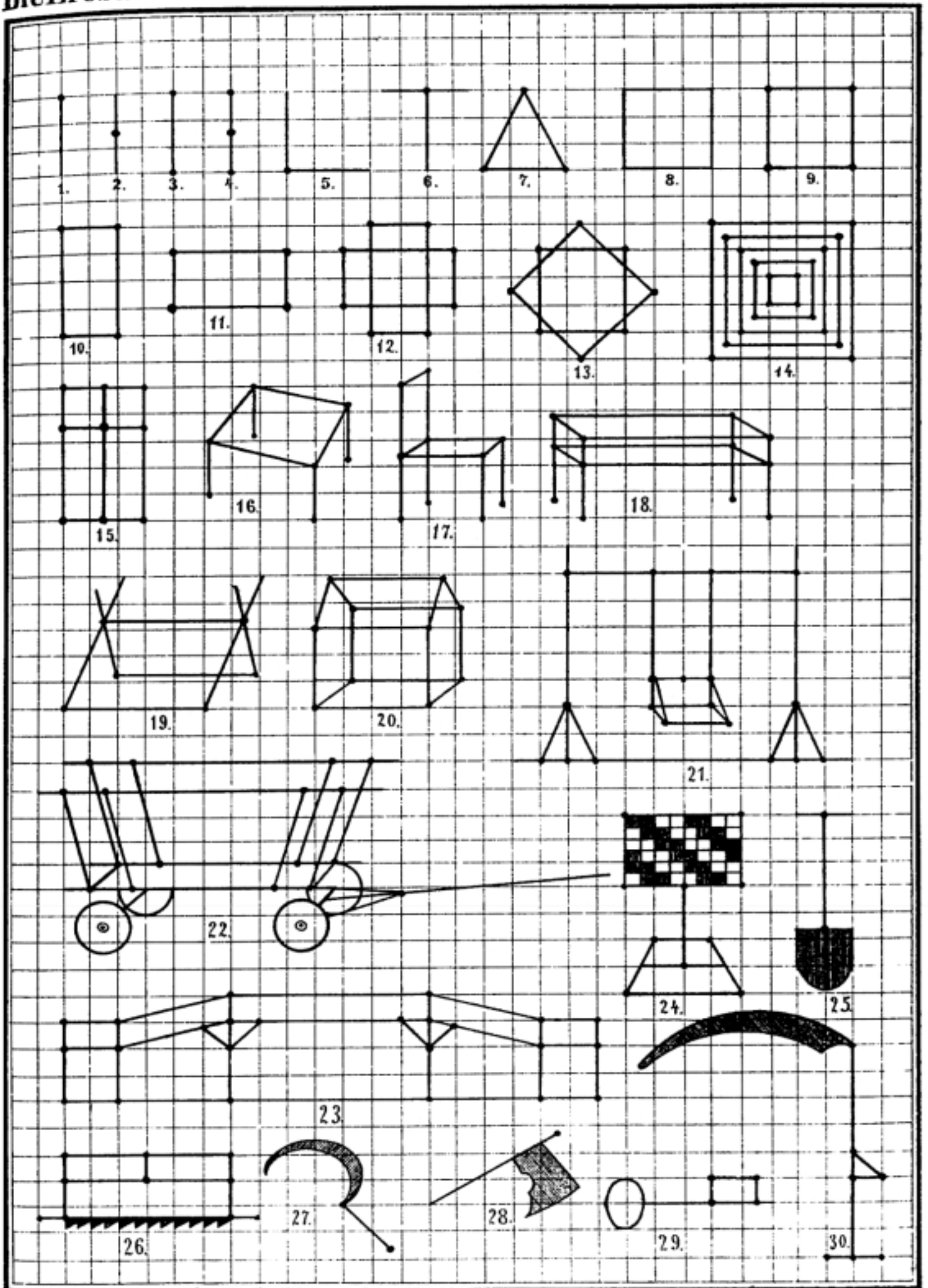

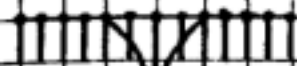

31.

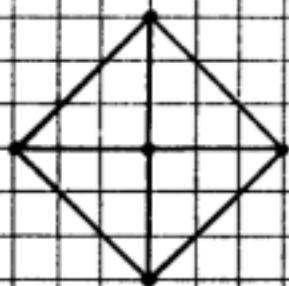

32.

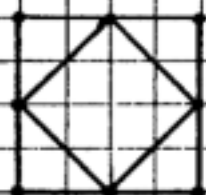

33.

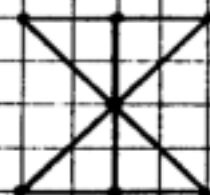

34.

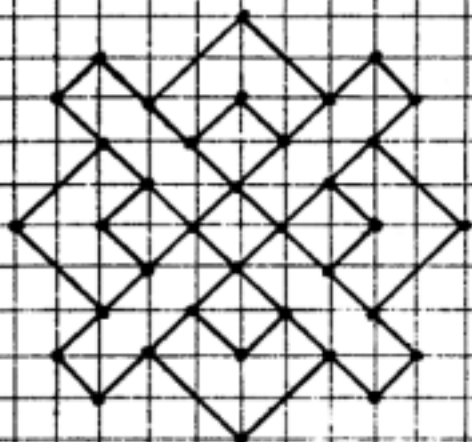

35.

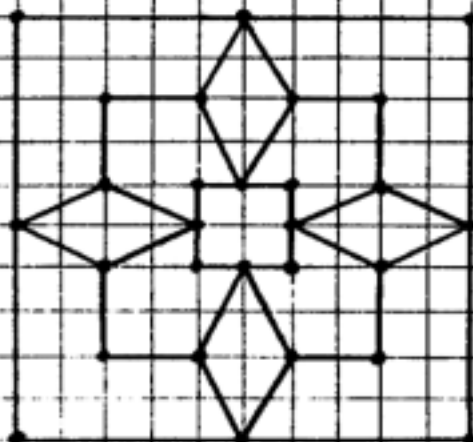

36.

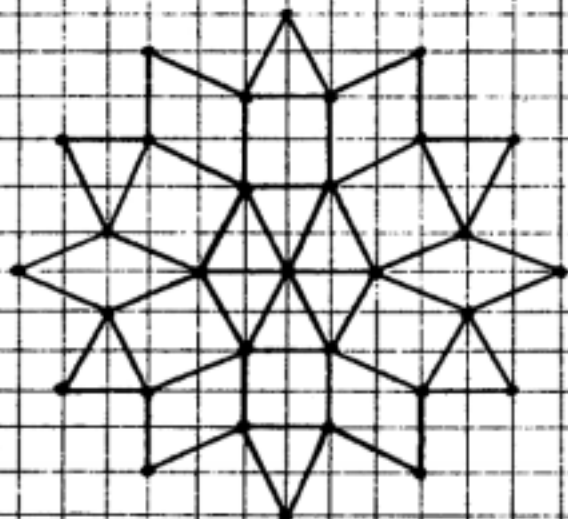

37.

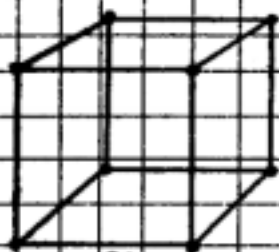

38.

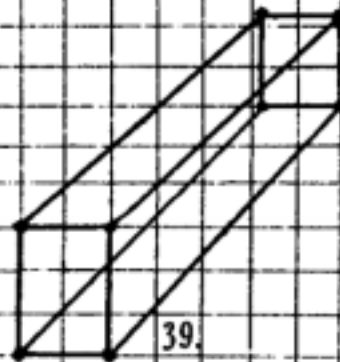

39.

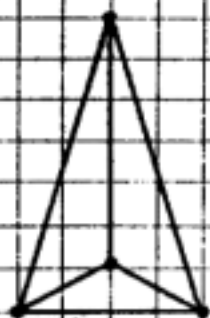

40.



41.

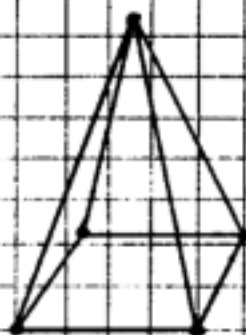

42.

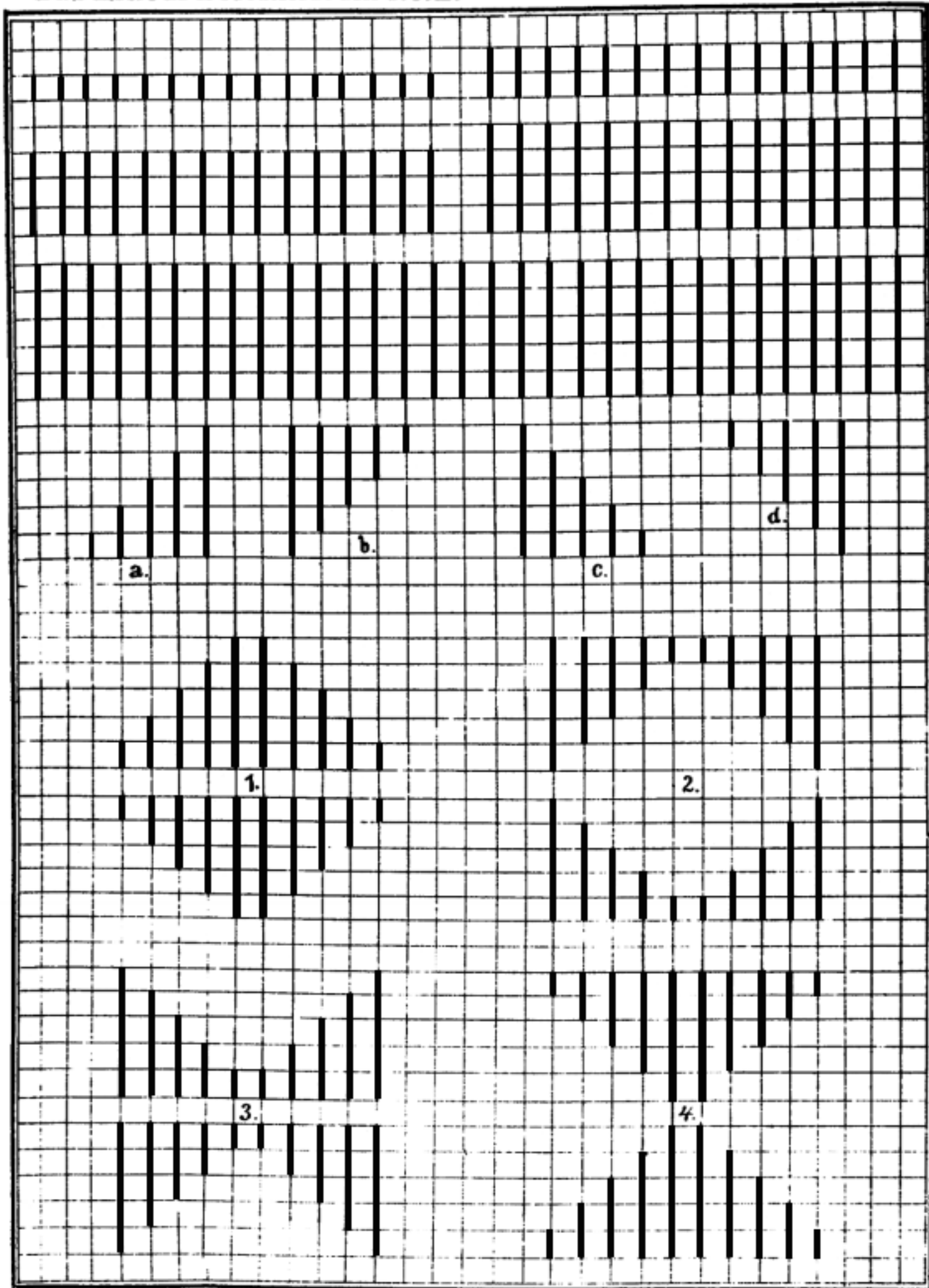

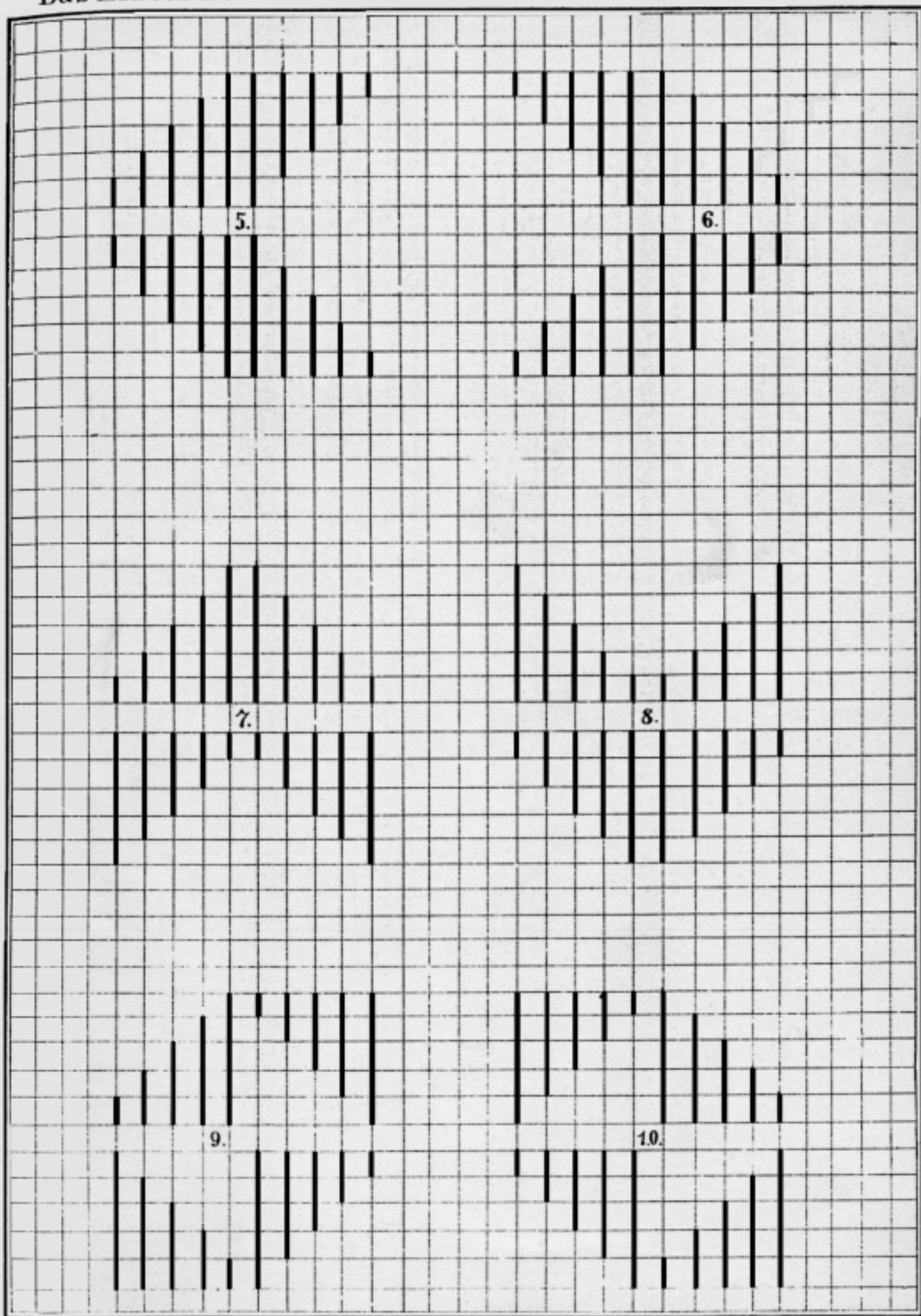

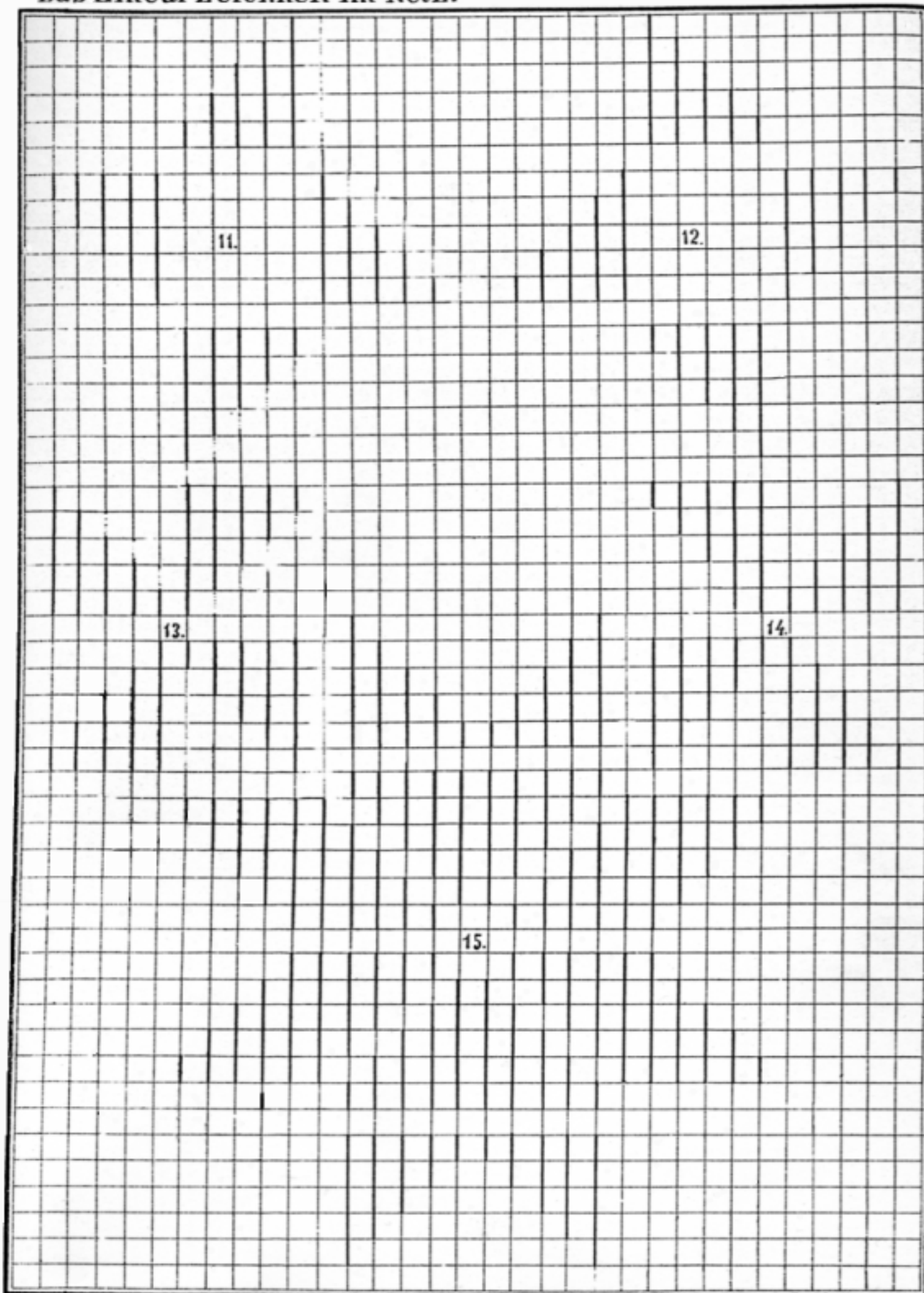

A large grid of graph paper, approximately 30 squares wide and 40 squares high. The grid is composed of thin, light gray lines. In the center of the grid, the number '16.' is printed in a small, black, sans-serif font. The number is positioned roughly in the middle of both the horizontal and vertical axes of the grid.

16.

17.

18.

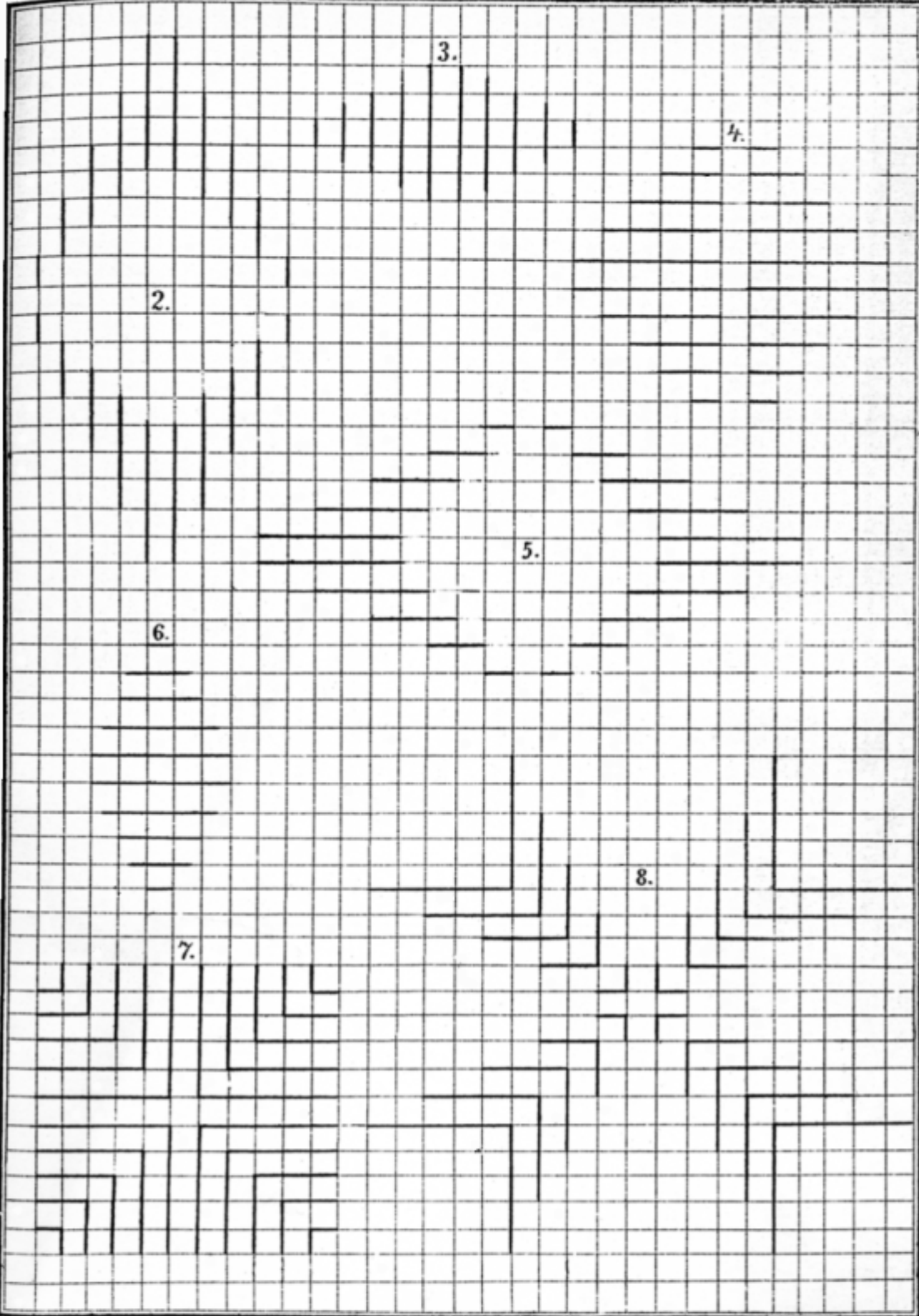

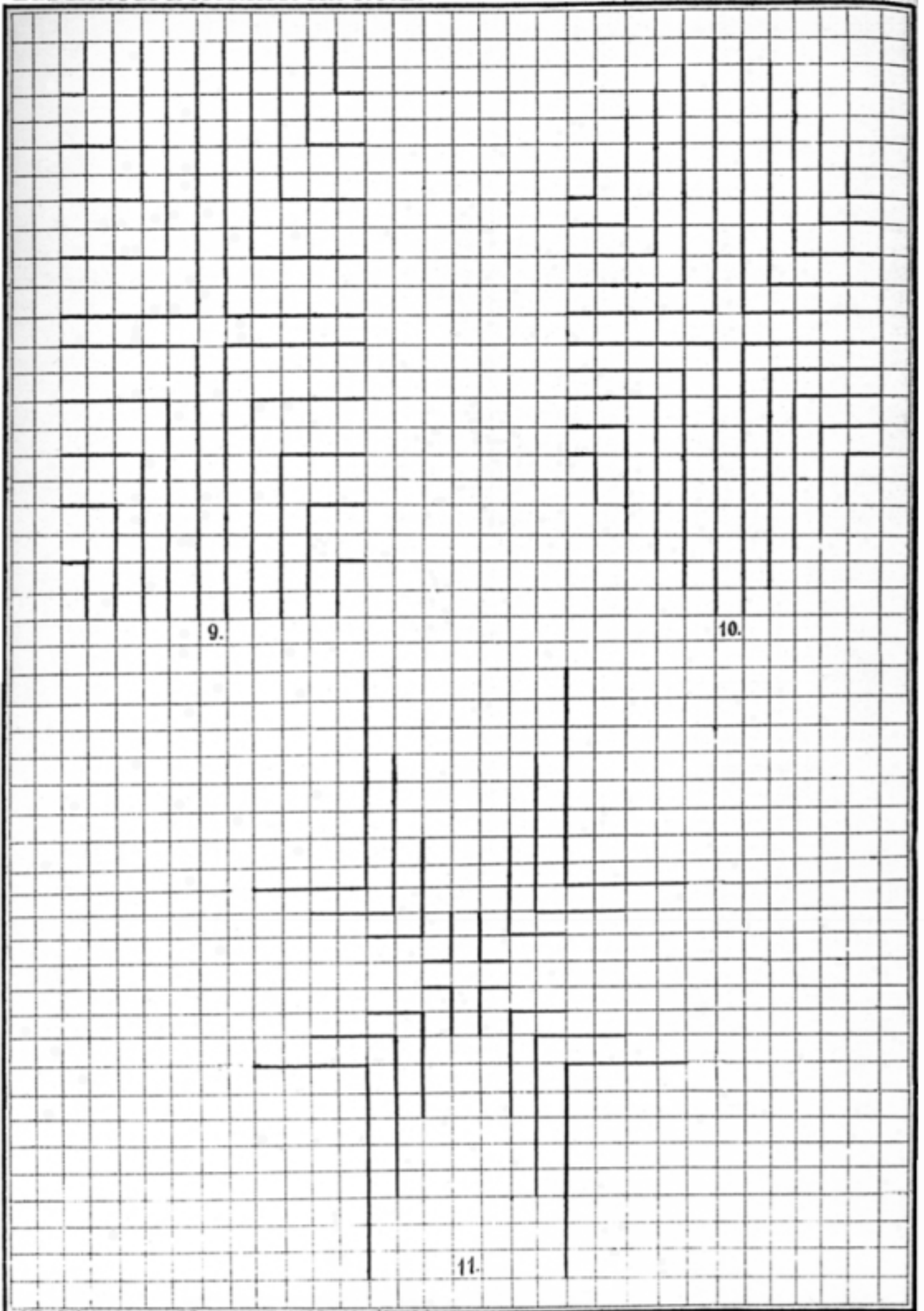

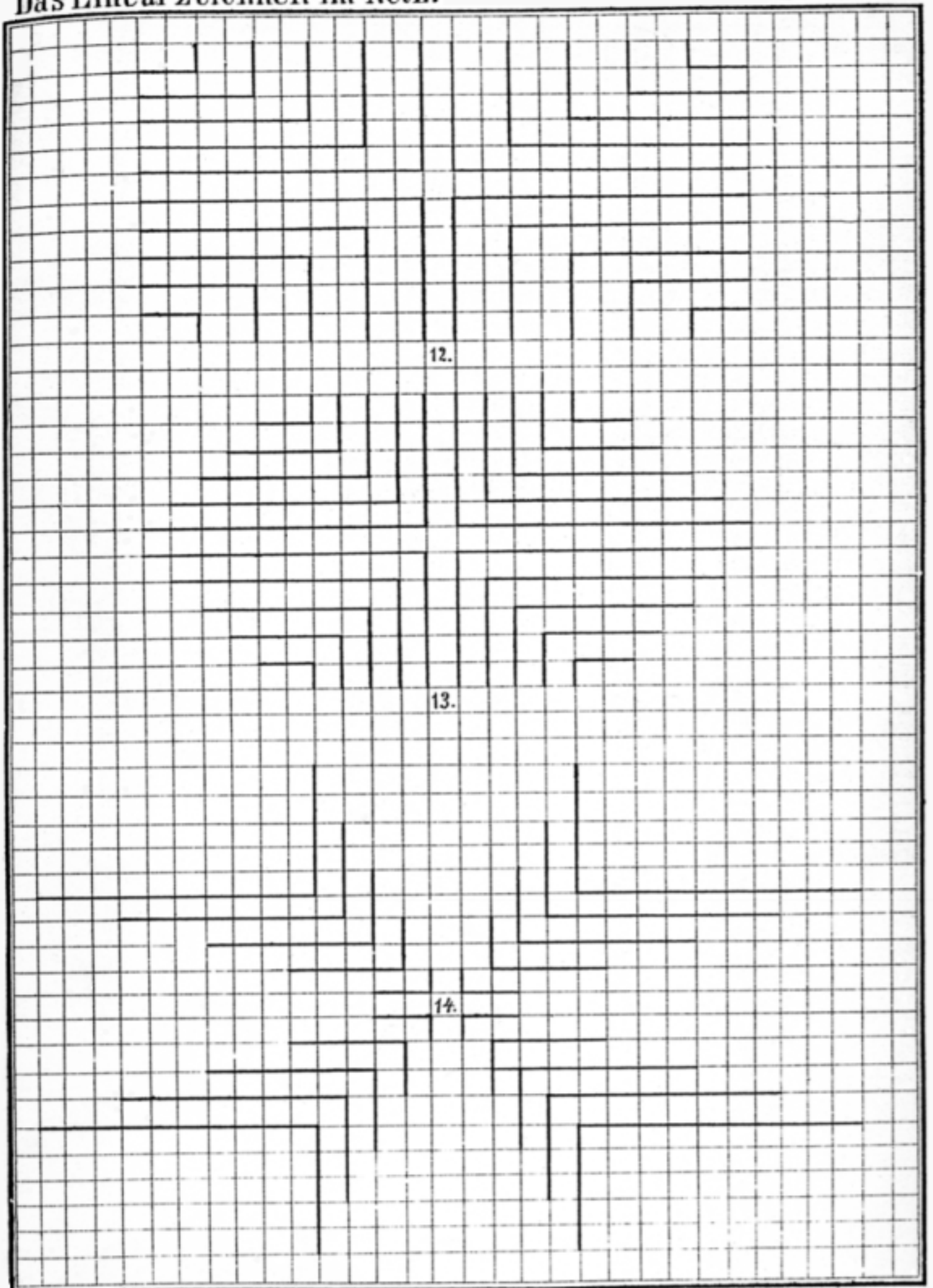

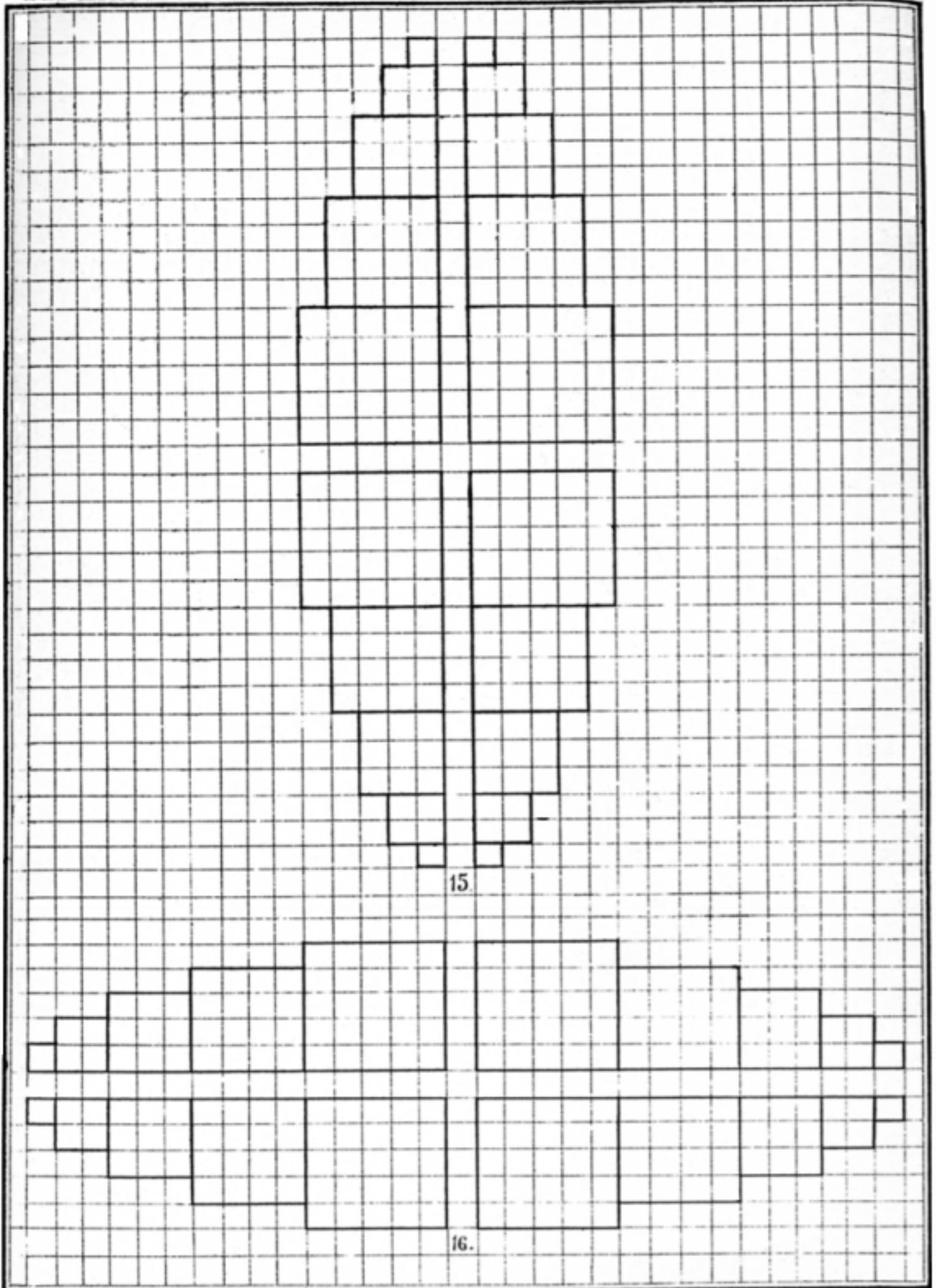

15.

16.

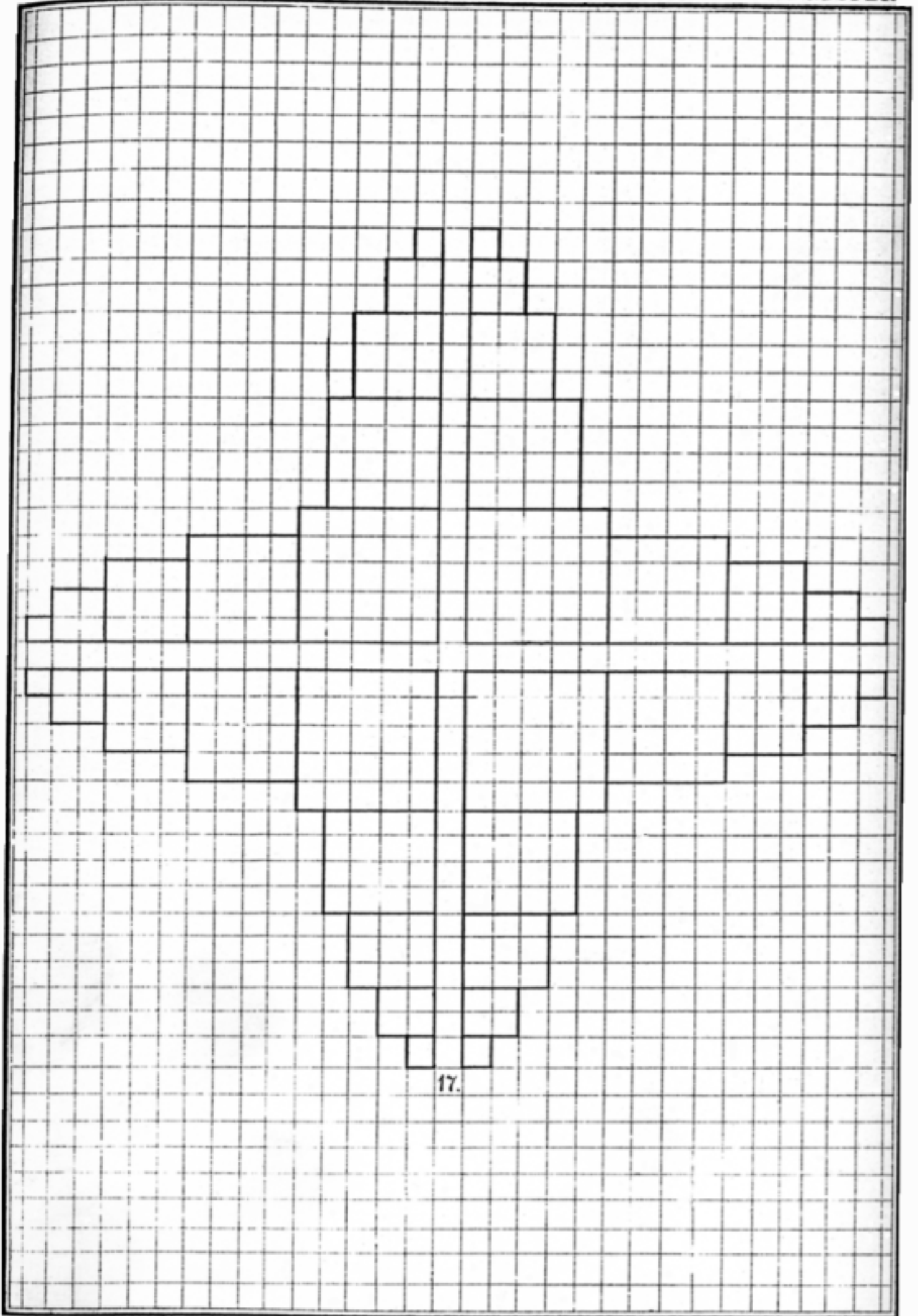

17.

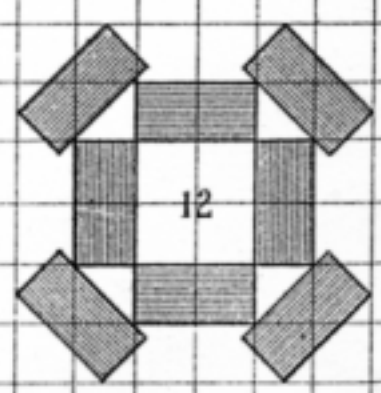
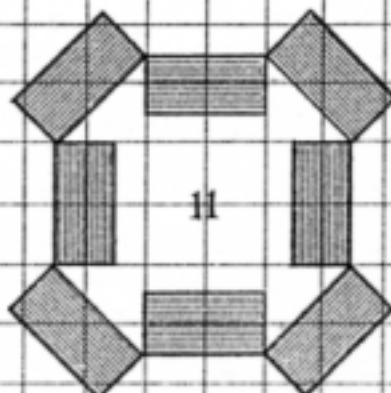
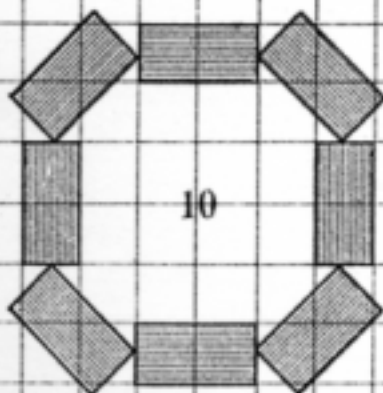
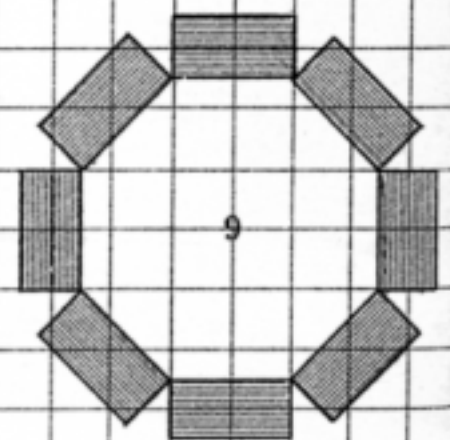
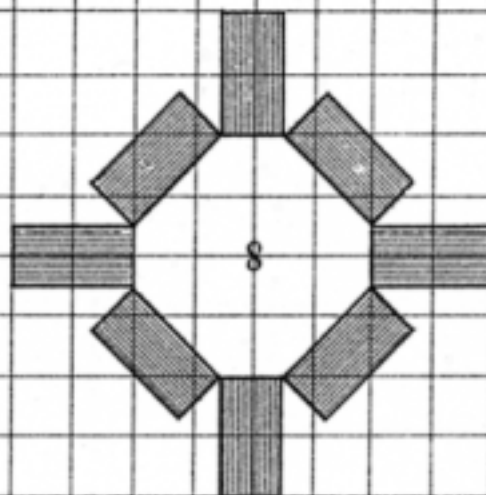
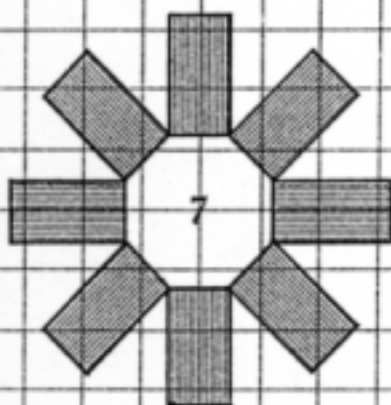
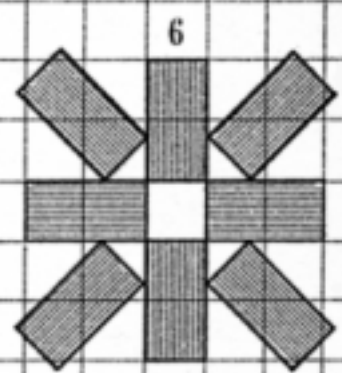
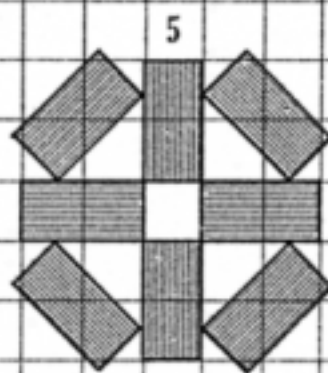
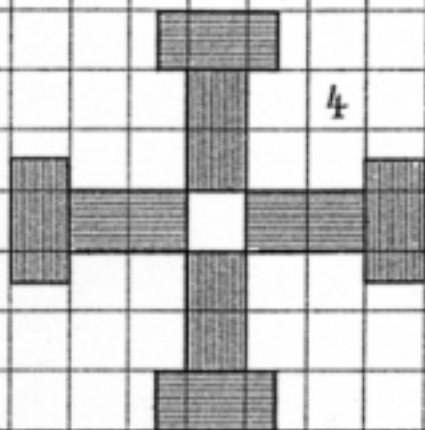
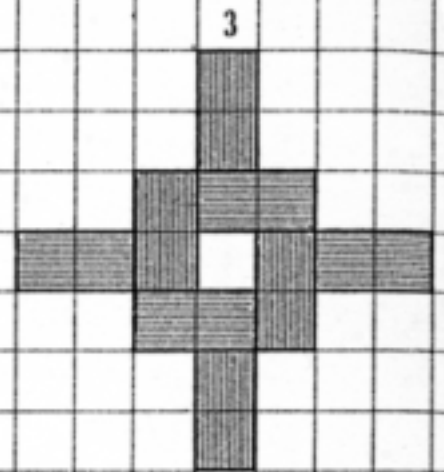
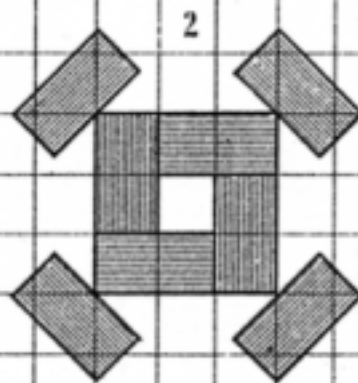
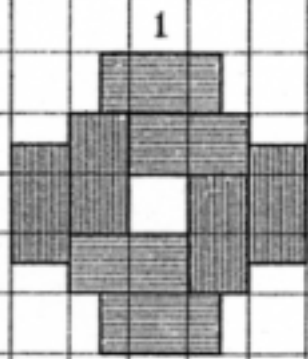

Erfindungen.

1



2

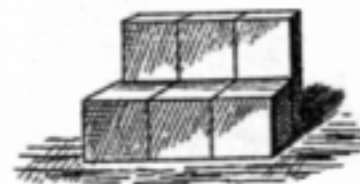
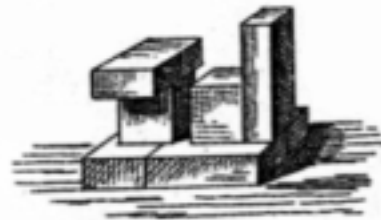

Ställe.

Schulzimmer

3



4

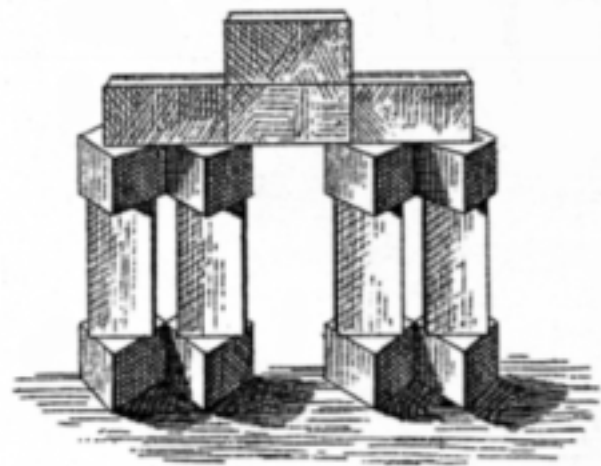

Terrasse.

Thor.

Erfindungen.

5

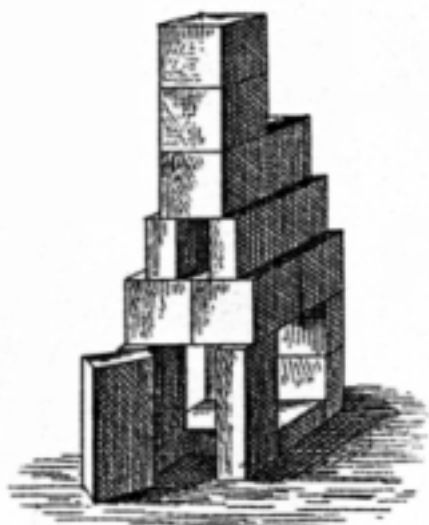

Kirche.

6



Stall u. Wagenremise.

7



Denkmal.

8

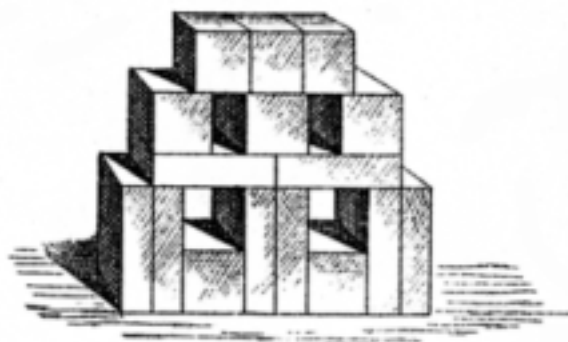

Haus.

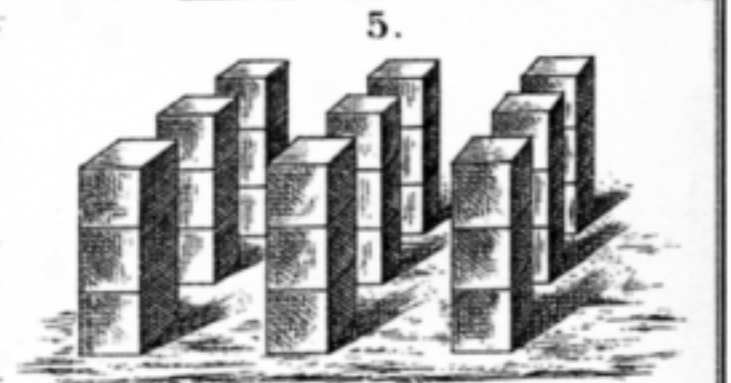
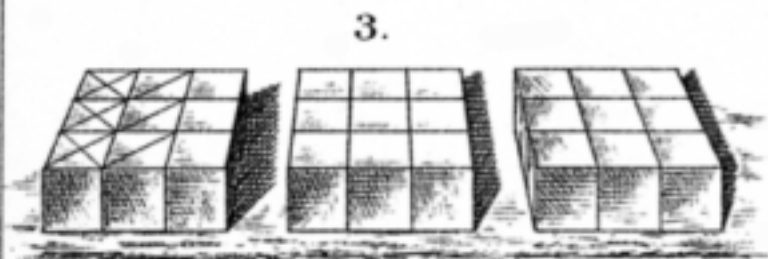
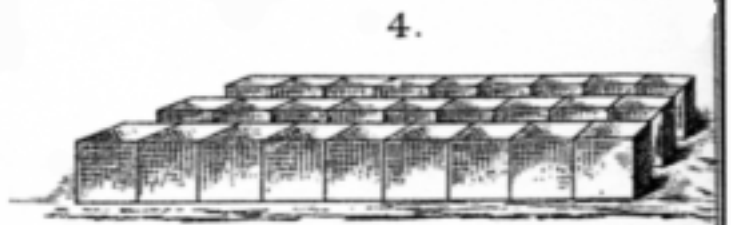
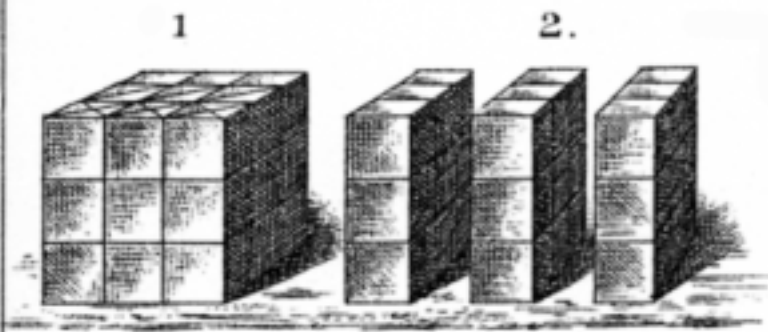

6.

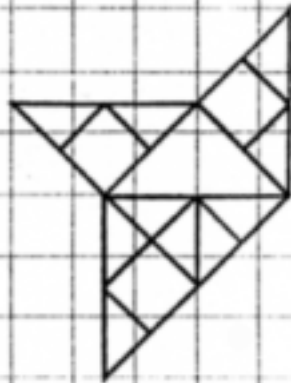
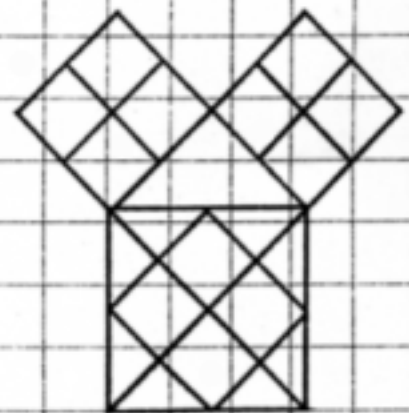
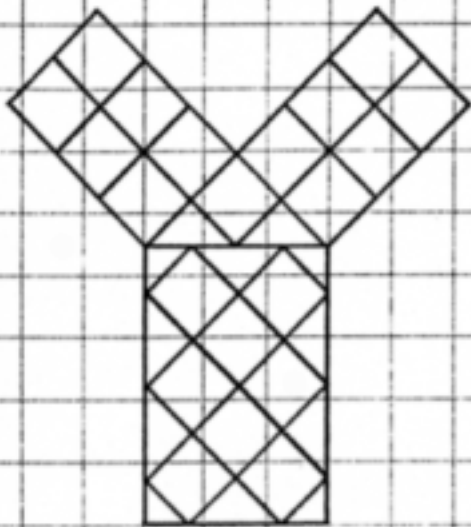

1.

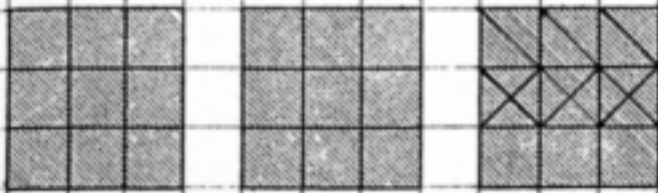

2.

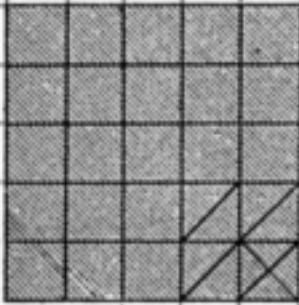

3.

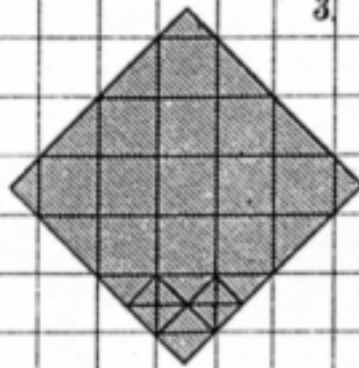

4.

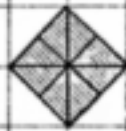
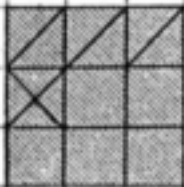
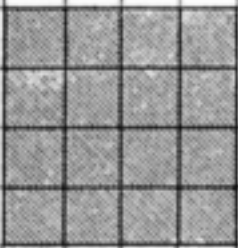

7.

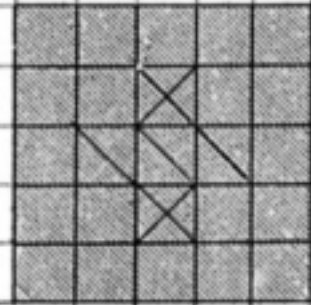

5.

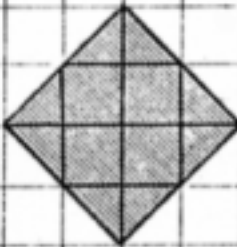
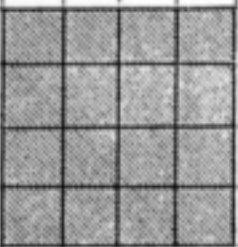

8.

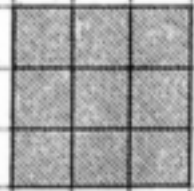
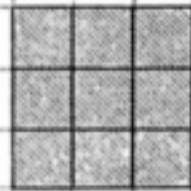

6.

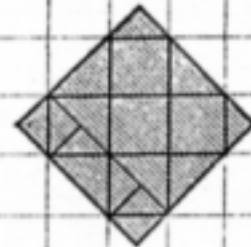
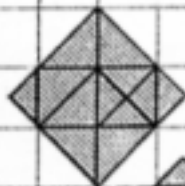
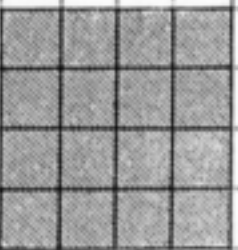

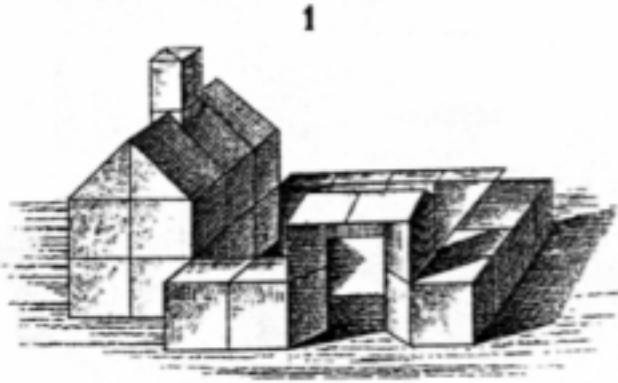

Haus mit Gartenzaun
und Thür.

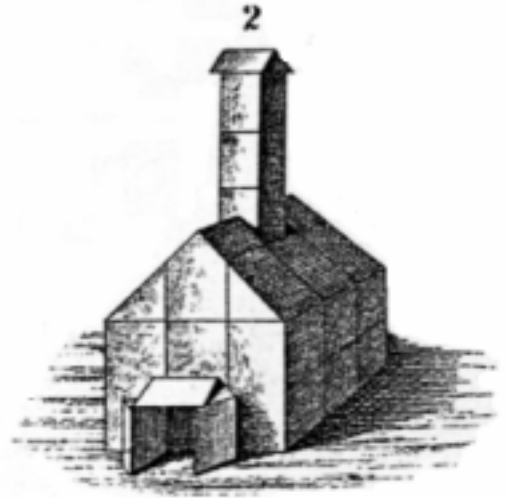

Fabrik.

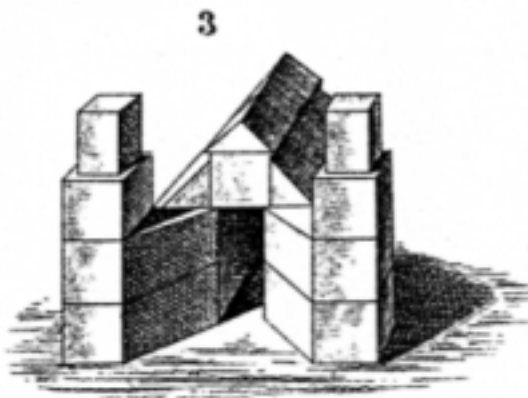

Bahnhofsperron.

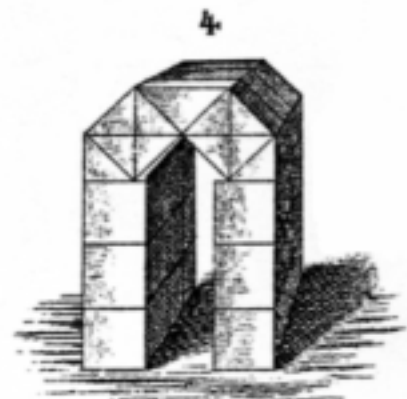

Tunnel.

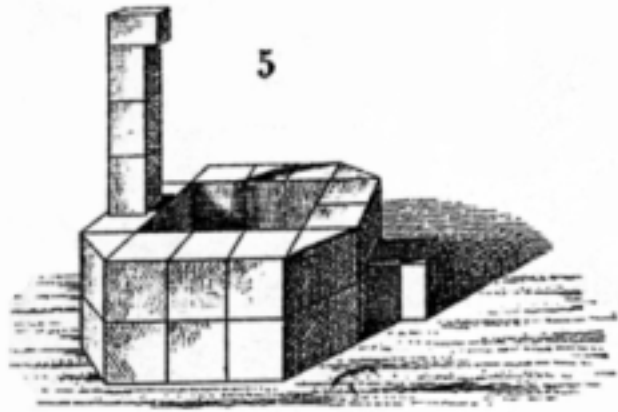

Wassertrog.

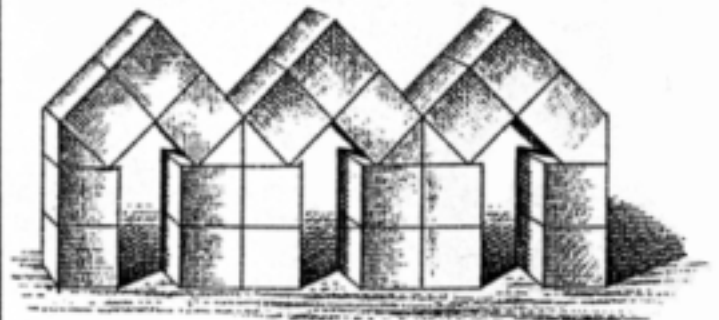
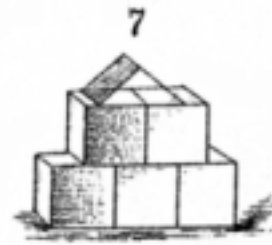

Thor und Haus.

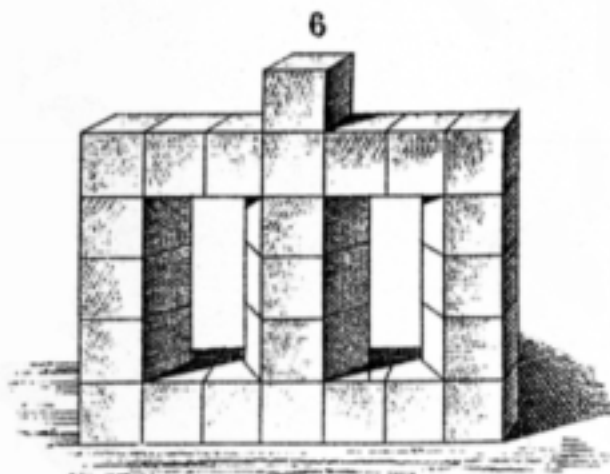

Doppelfenster.

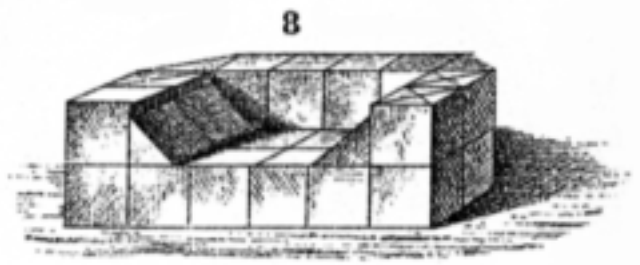

Sopha.

Erfindungen.

9

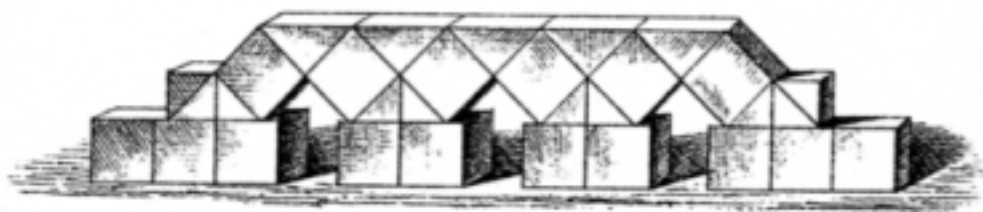
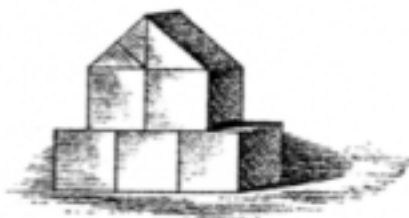

Brücke und Zollhaus.

10

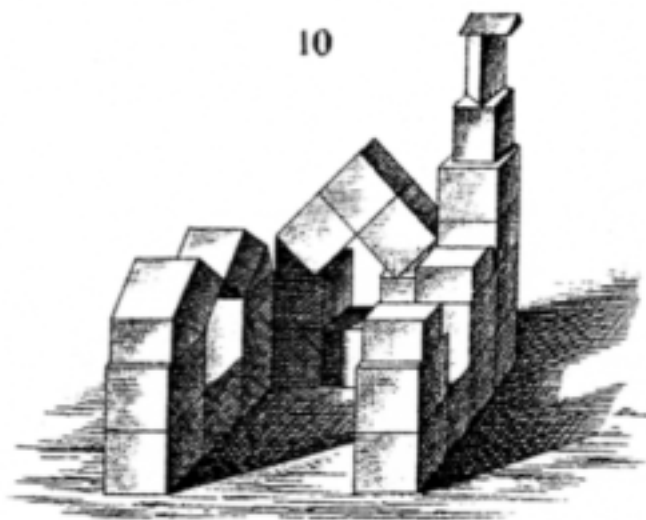

Ruine.

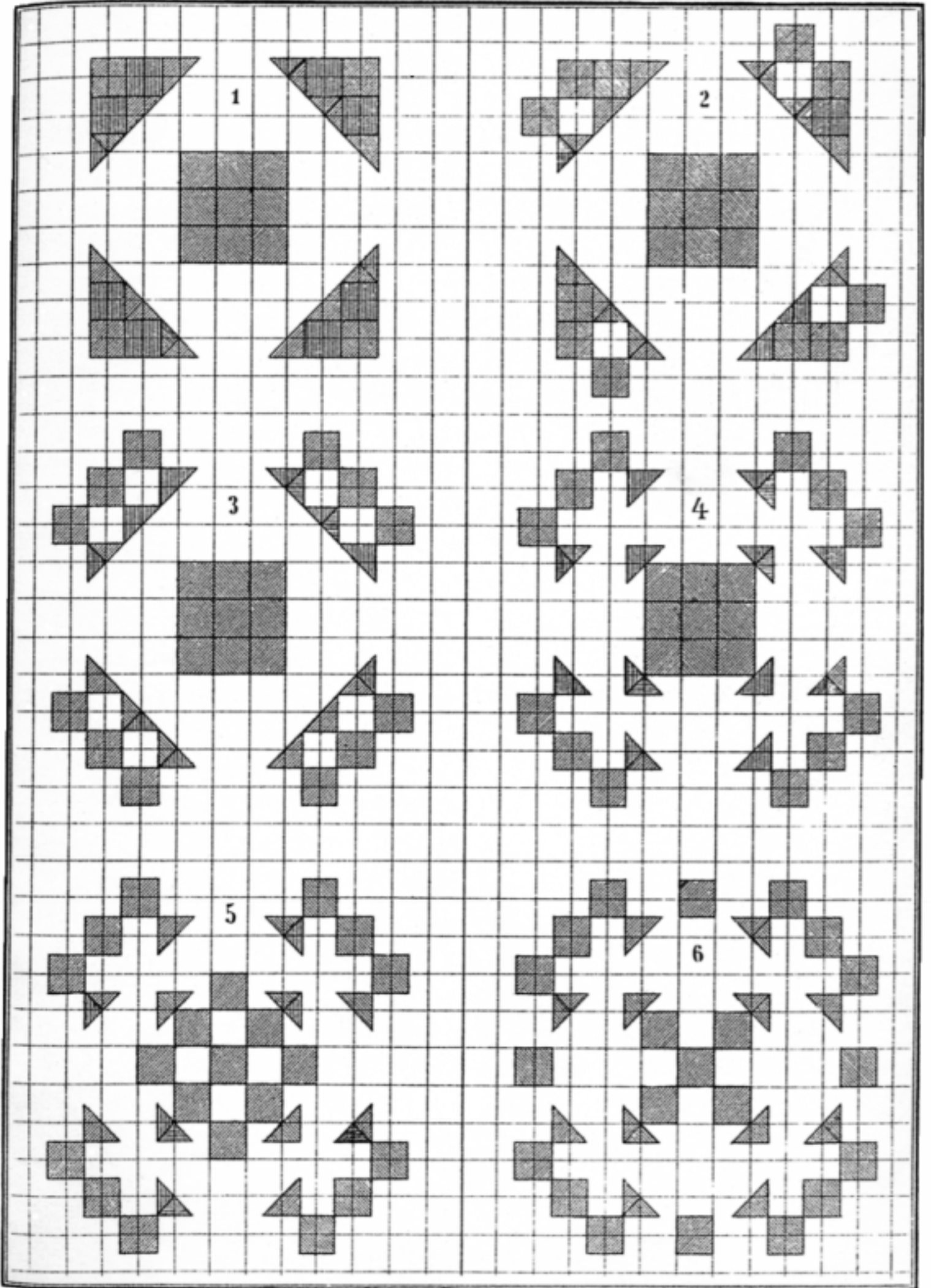

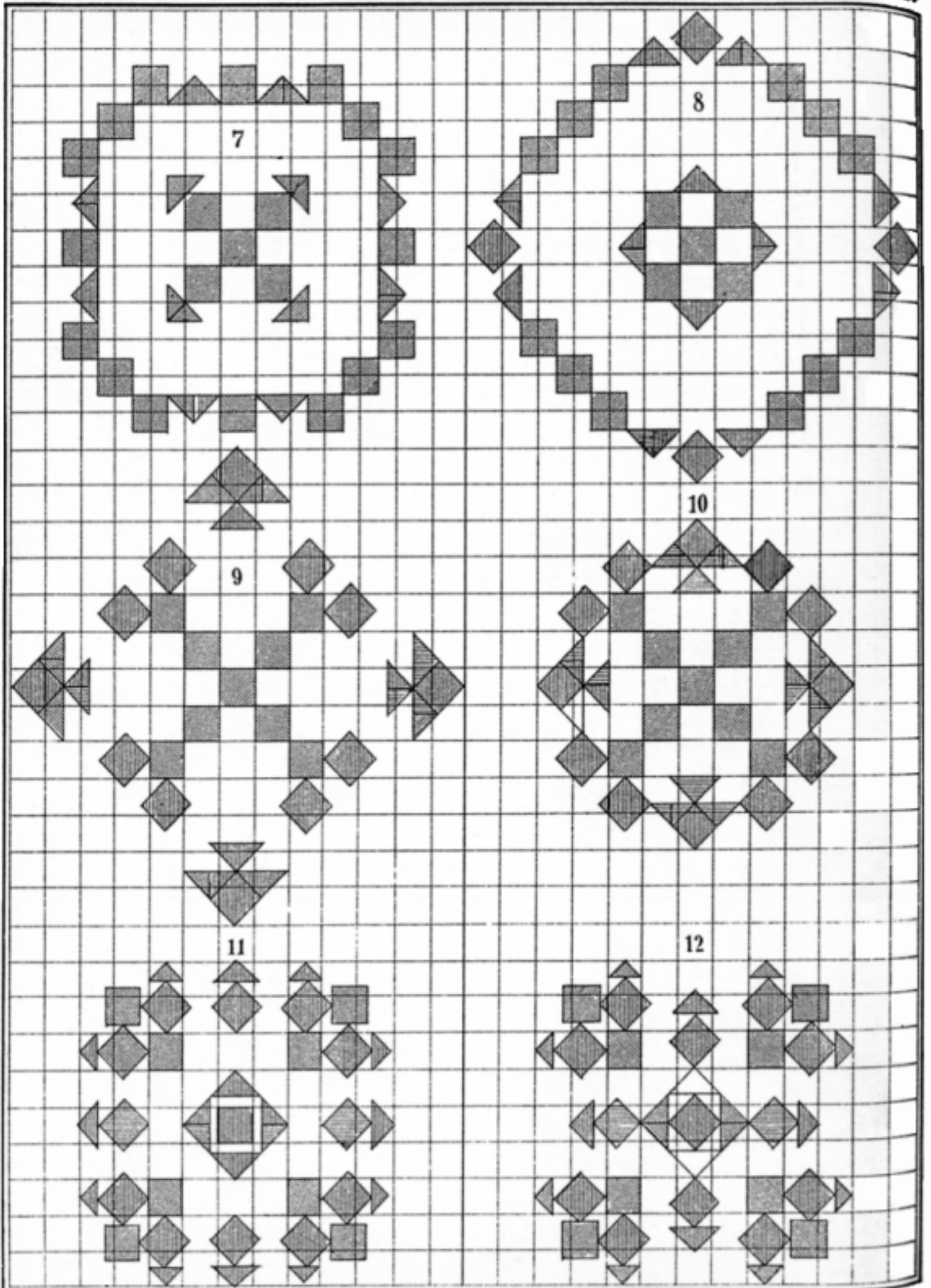

13

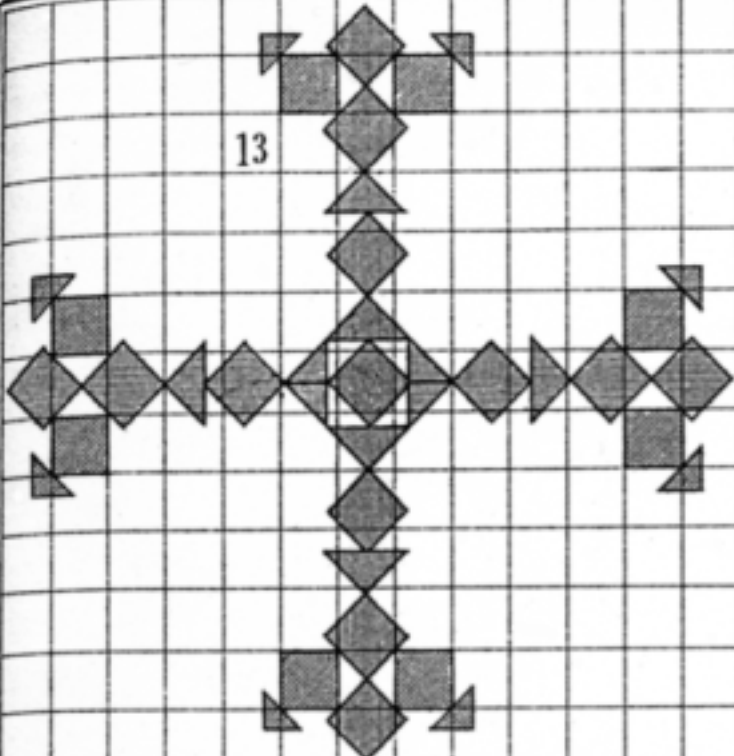

14

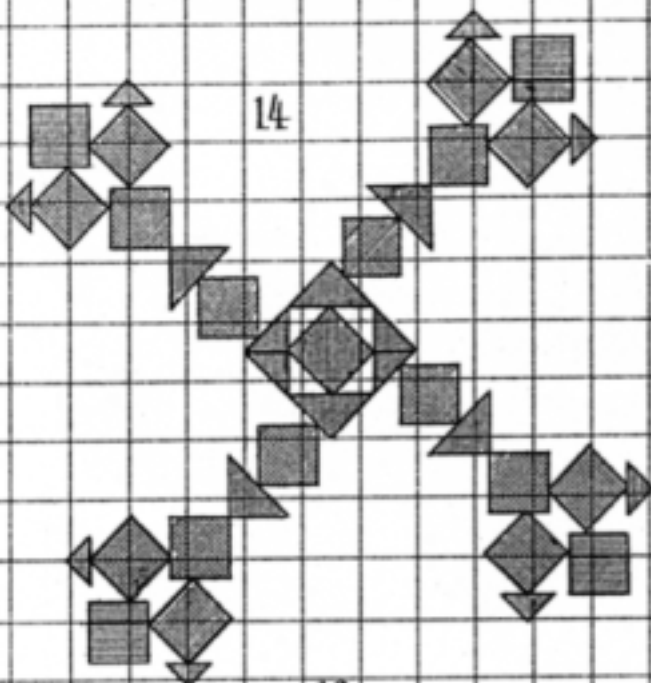

15

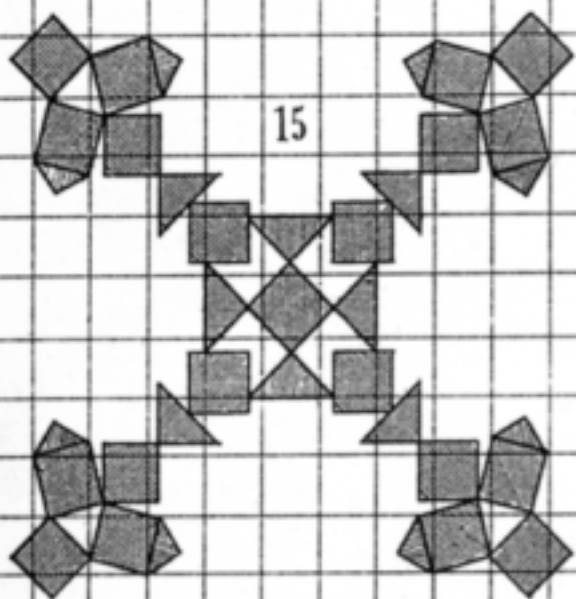

16

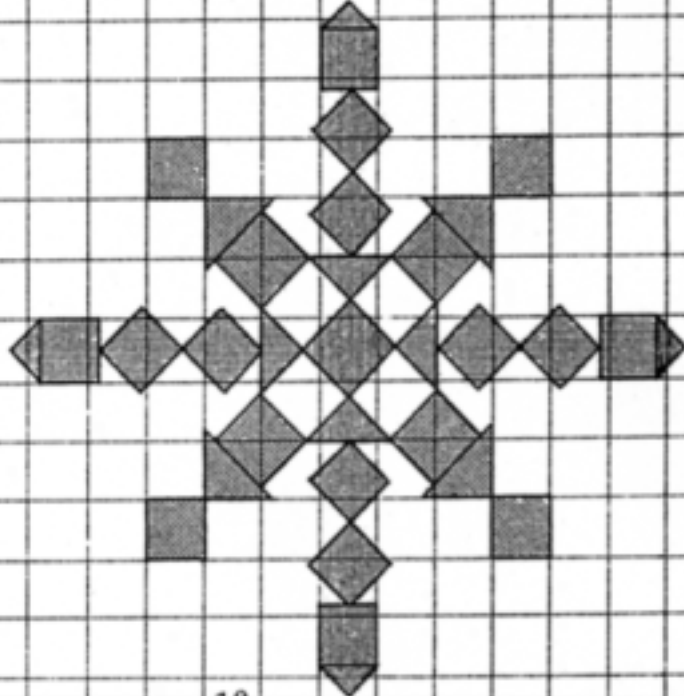

17

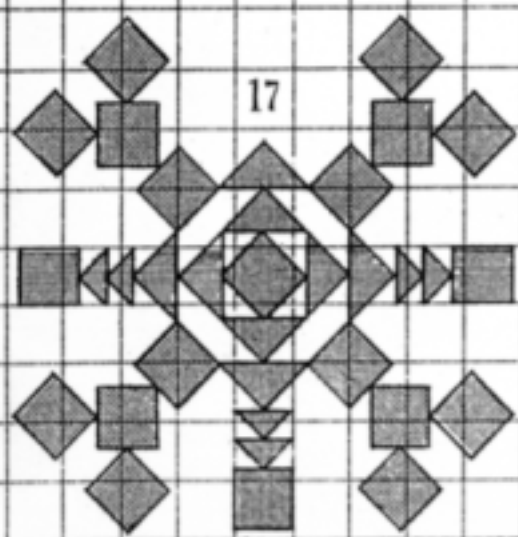

18

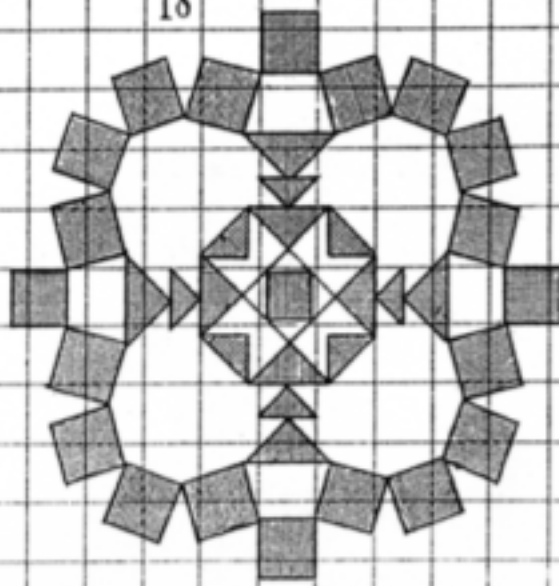

1.

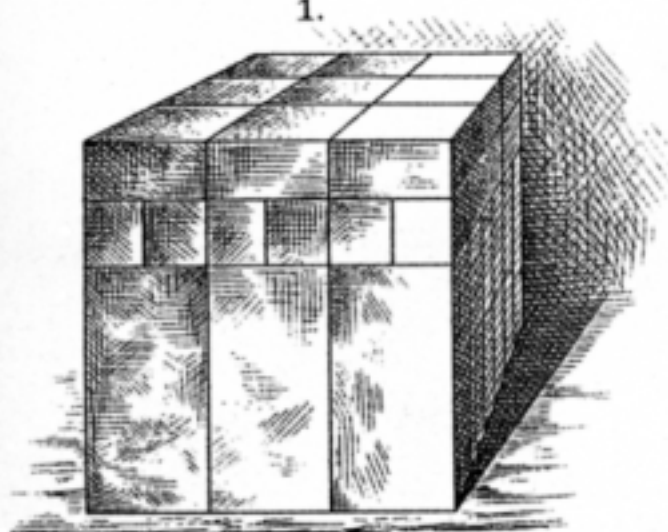

2.

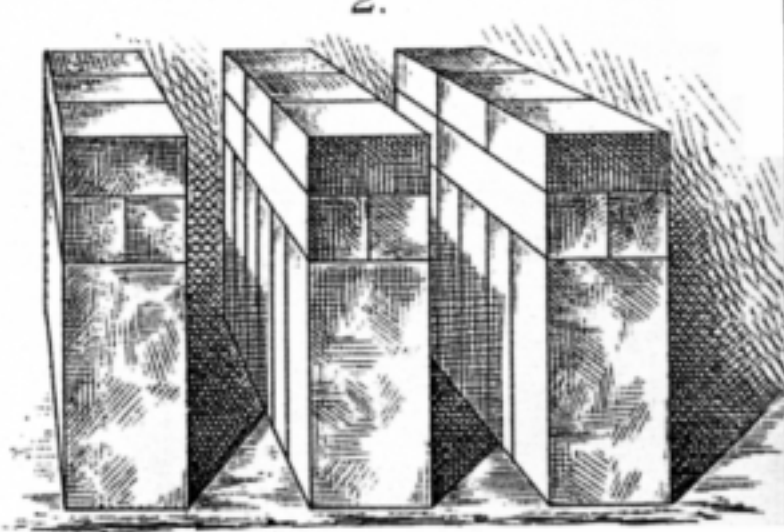

3.

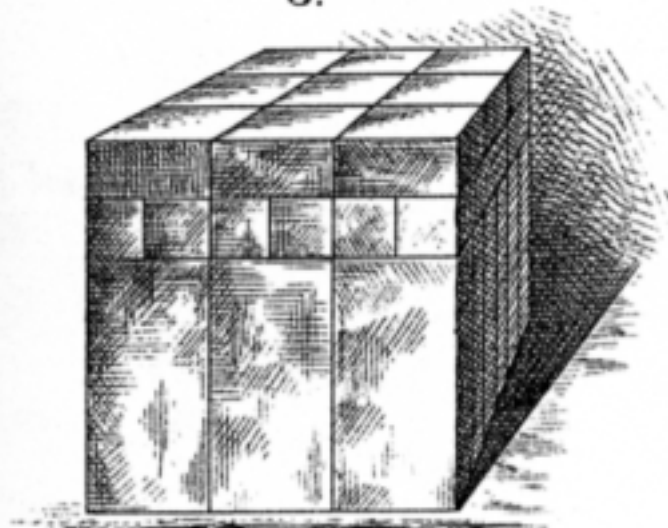

4.

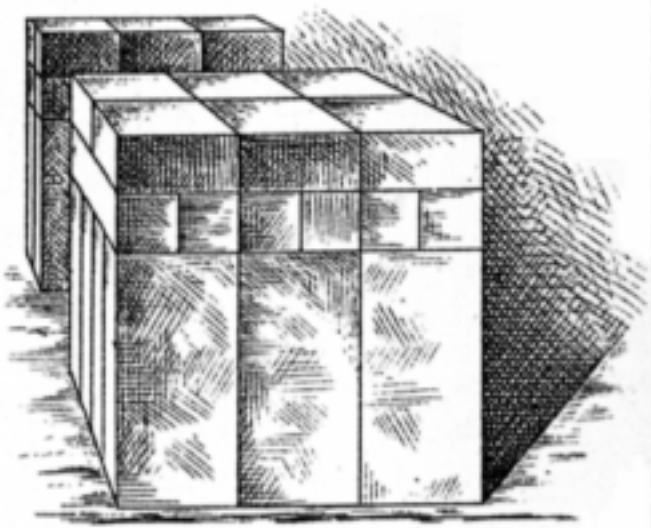

5.

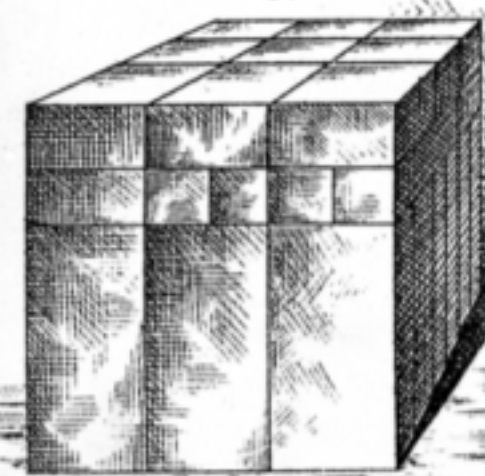

6.

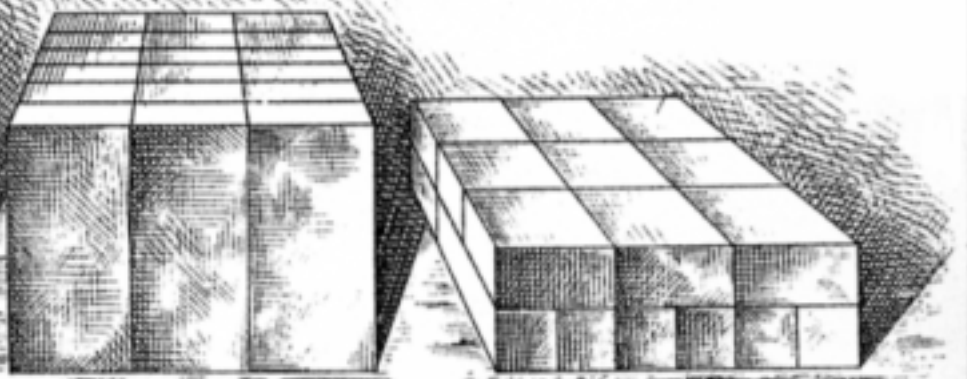



1.



Sofa und Tisch.

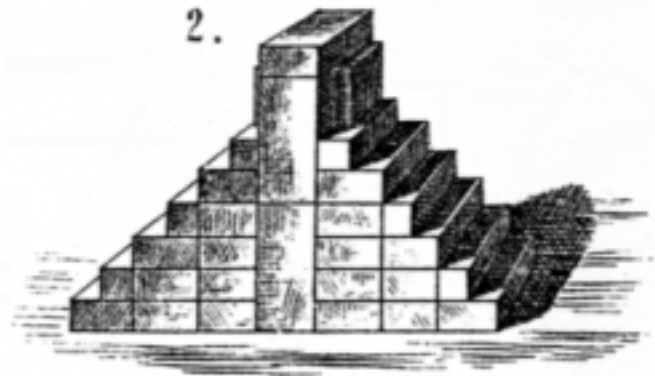

2.

Schacht mit Stufen.

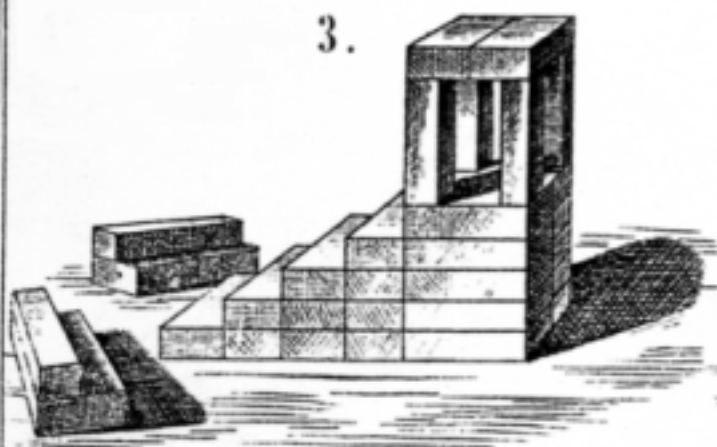

3.

Gartenhaus.

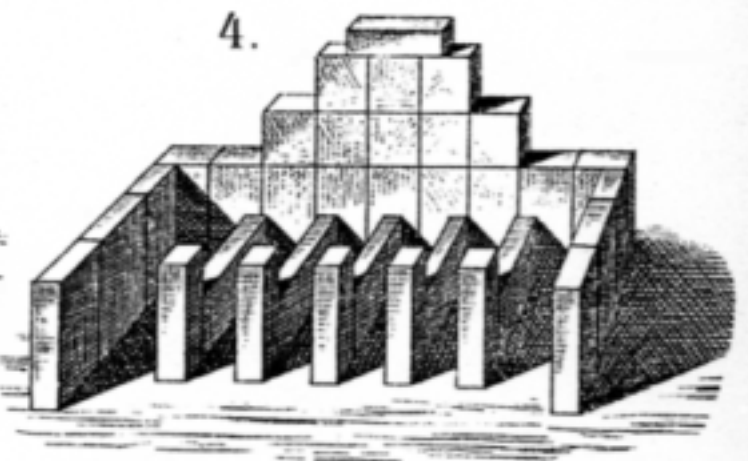

4.

Pferdestall.

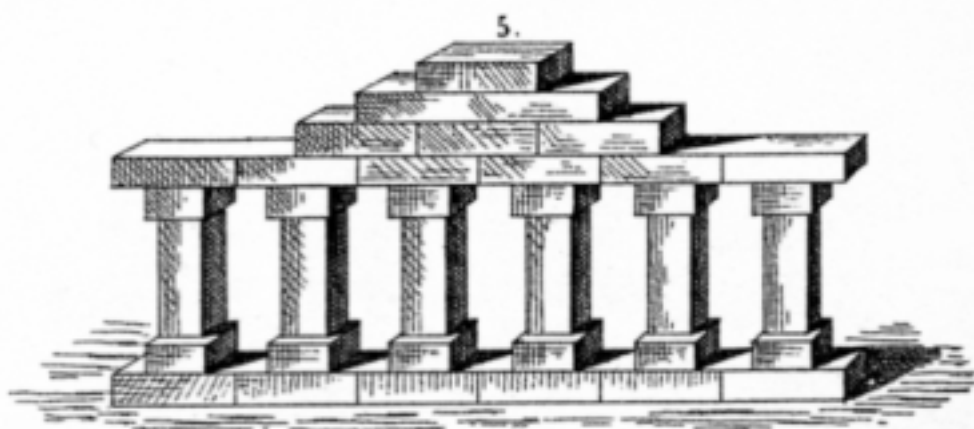

Säulenreihe.

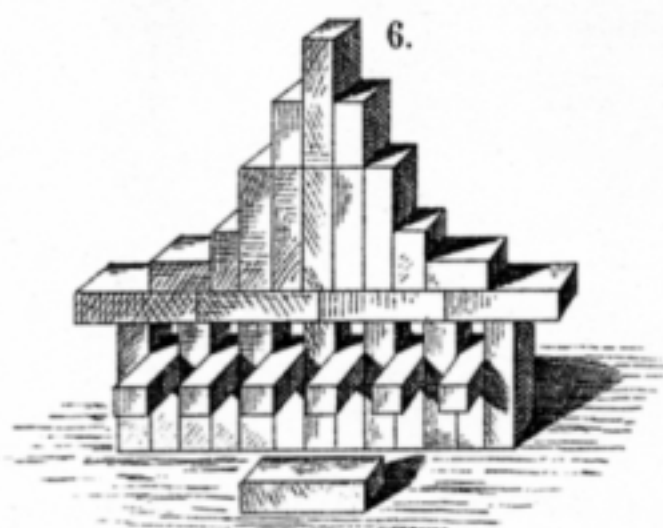

Orgel.



Portal.



Häuschen.

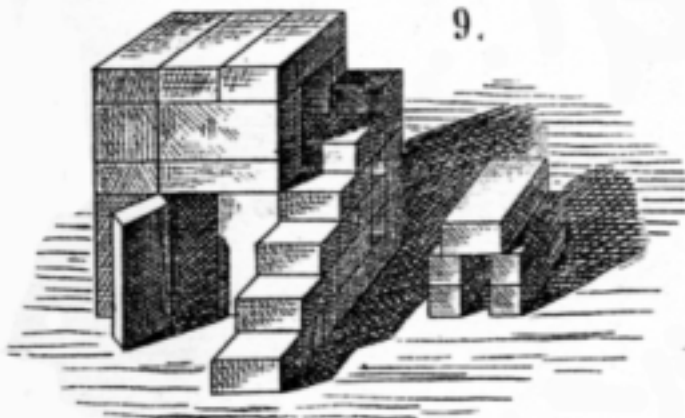

Gänse- und Hühnerstall.
u. Hundehütte.

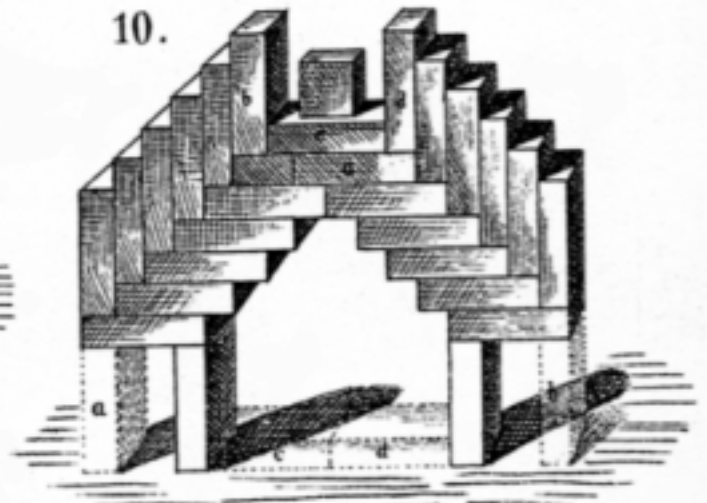

Aegyptisches Thor.

Bauten mit der V. u. VI. Gabe.
Erfindungen.

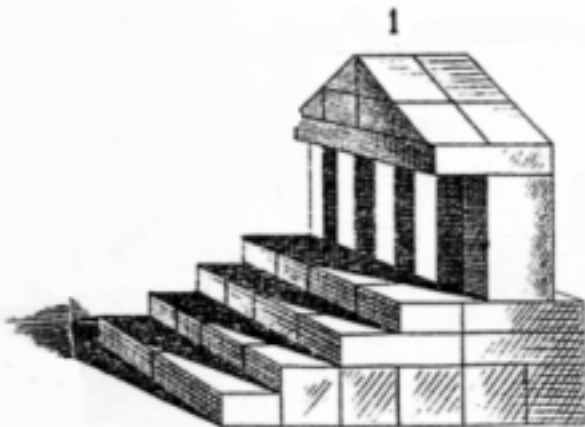

Römischer Tempel.

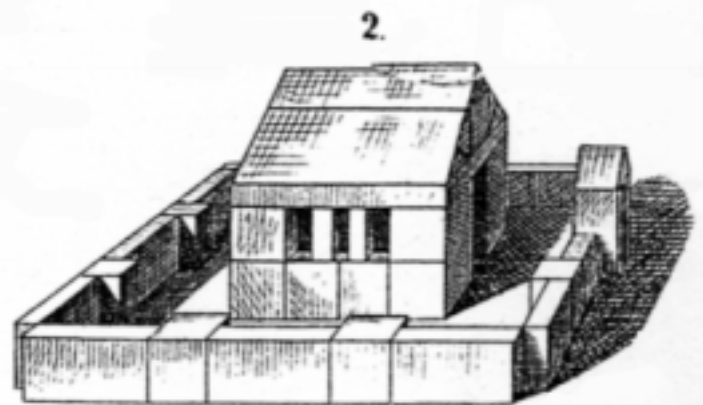

Haus mit Gartenzaun.

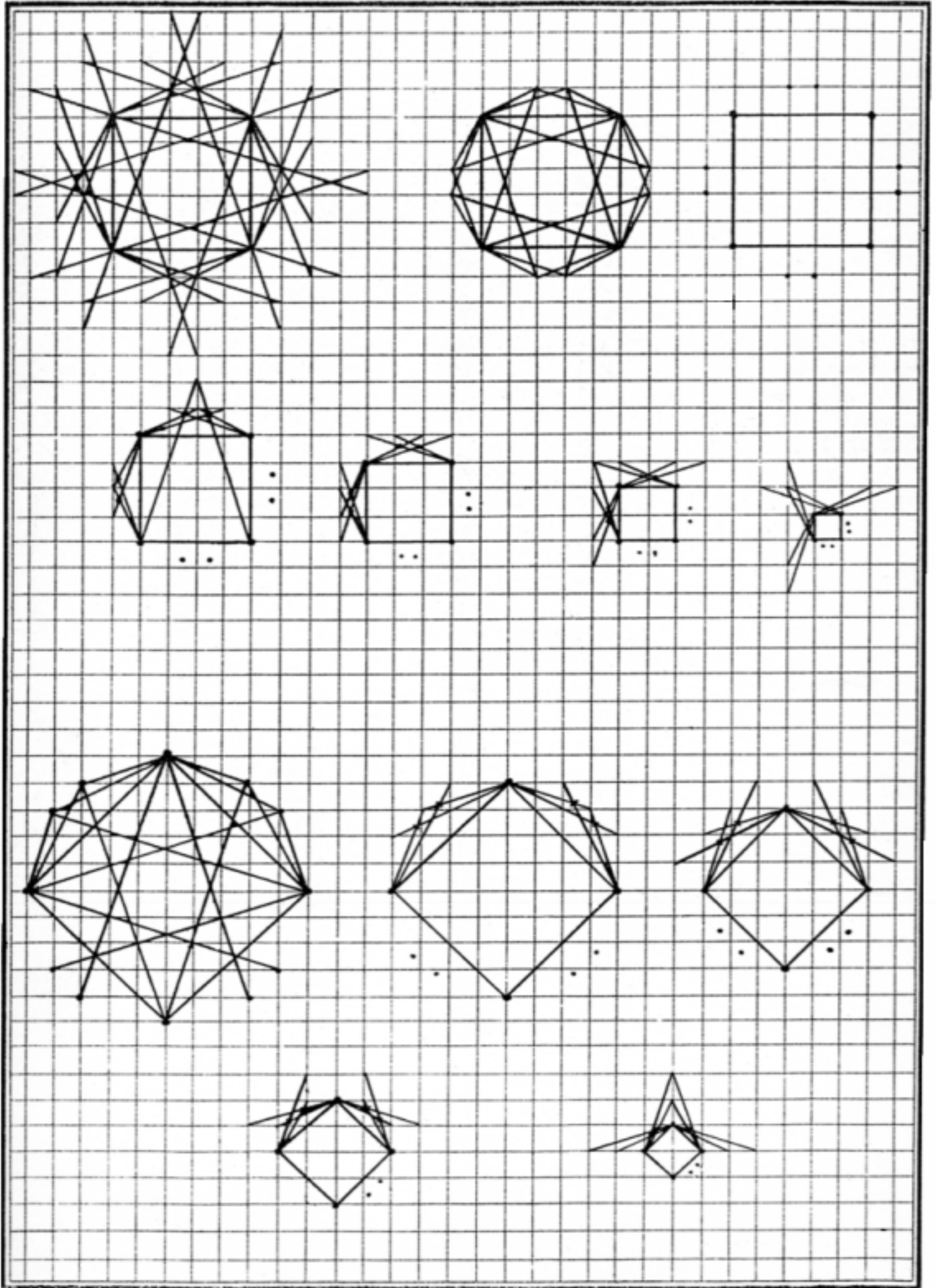

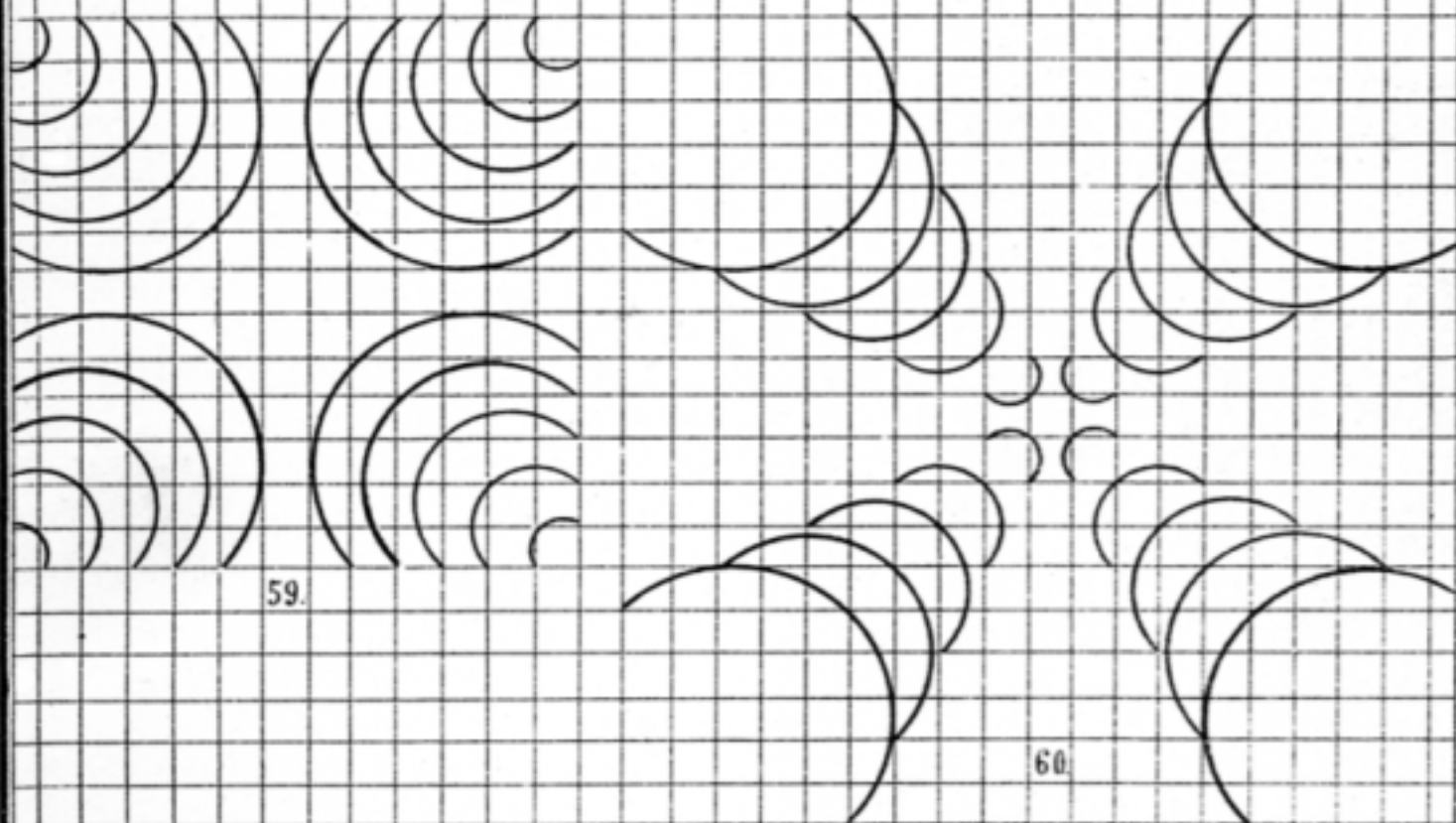

59.

60.

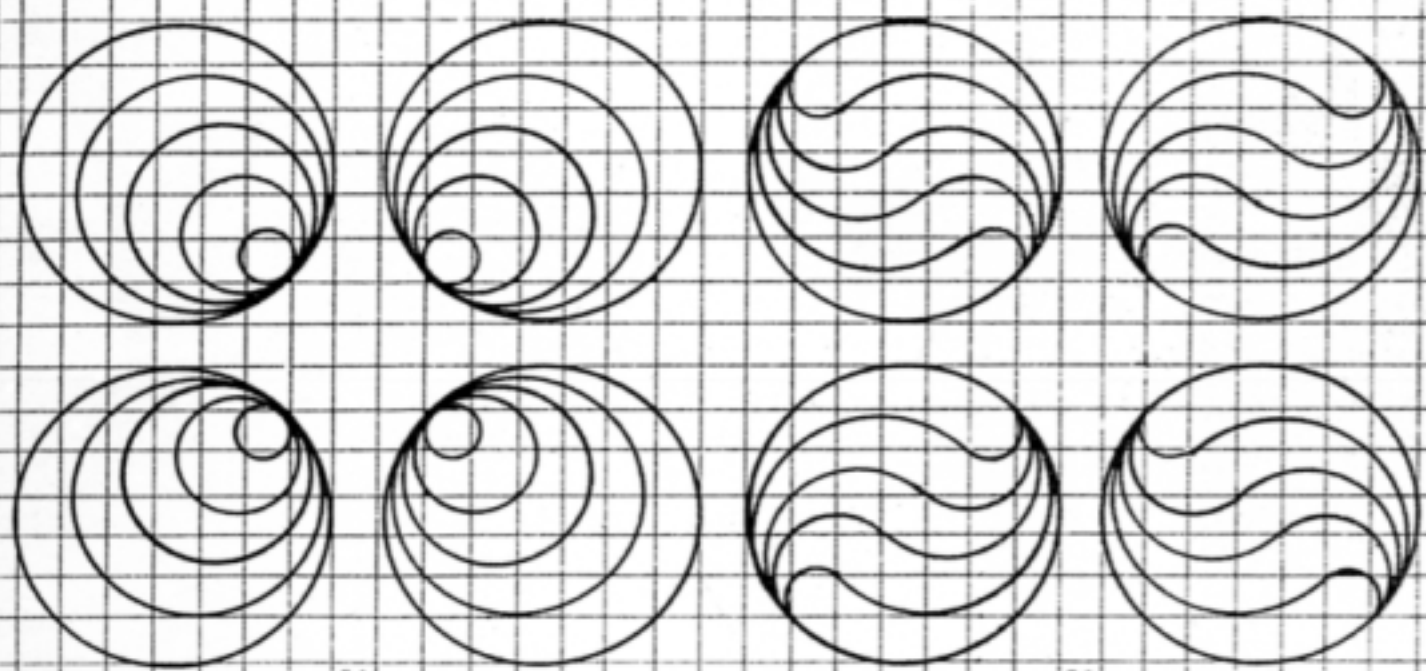

61.

62.

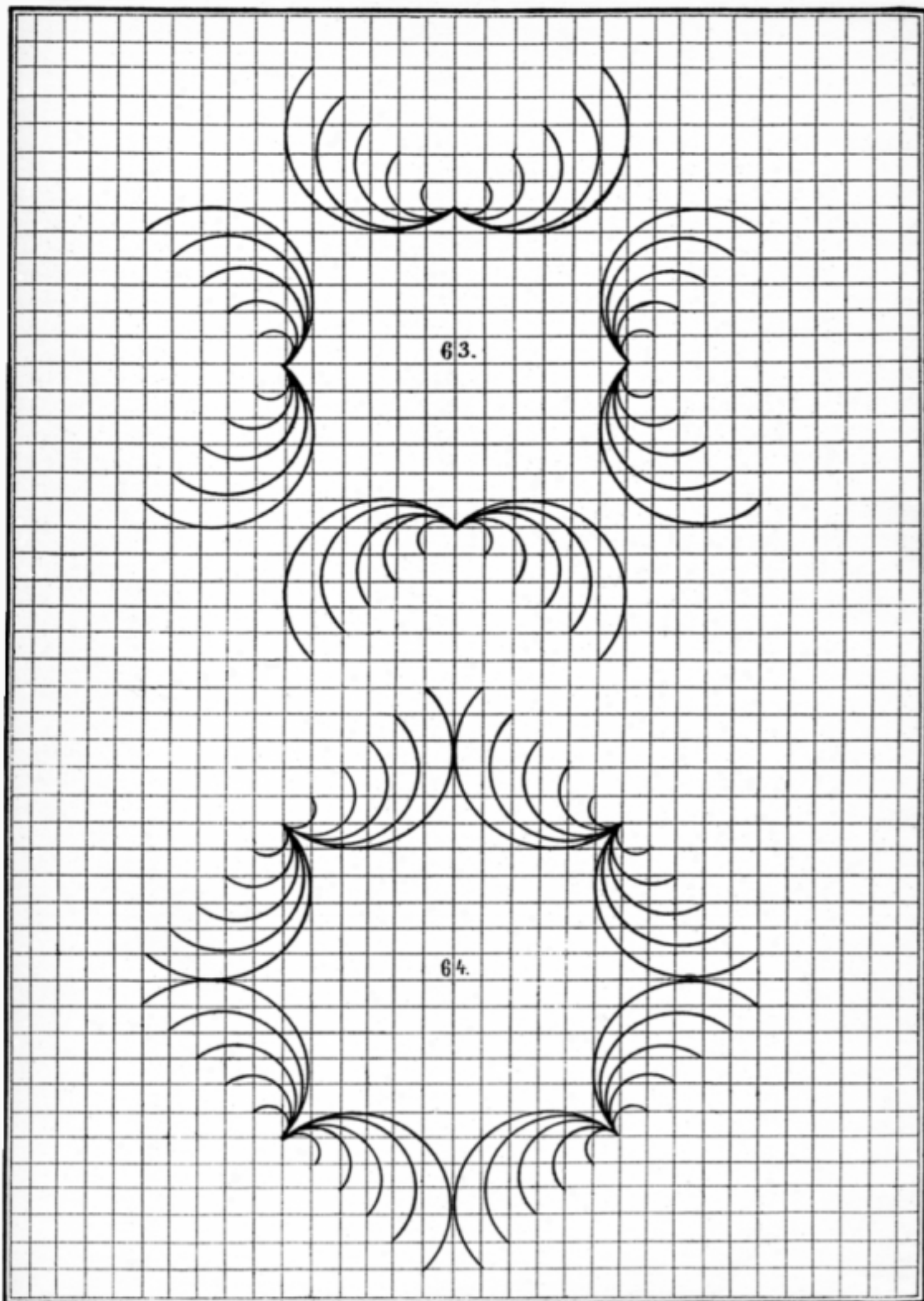

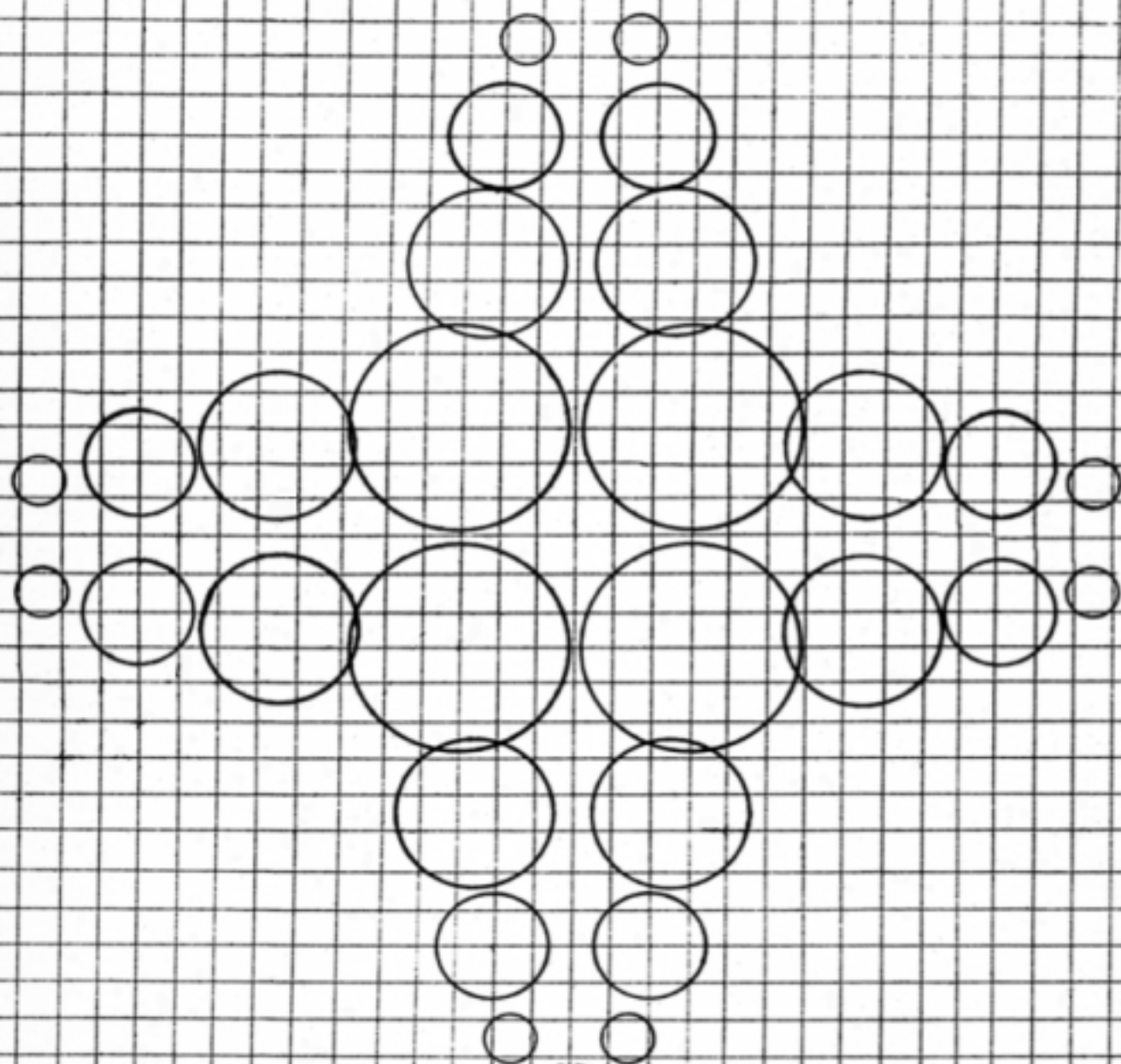

65.

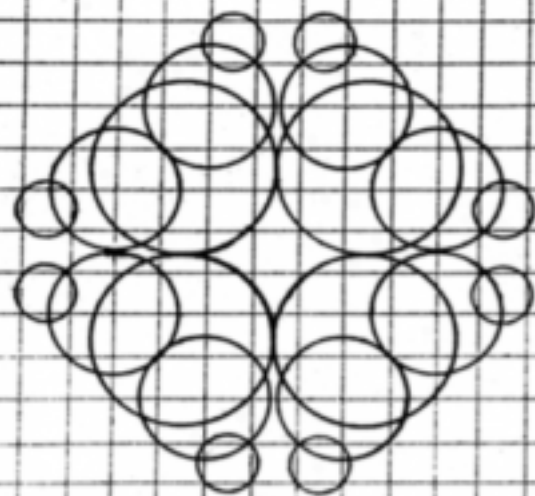

66

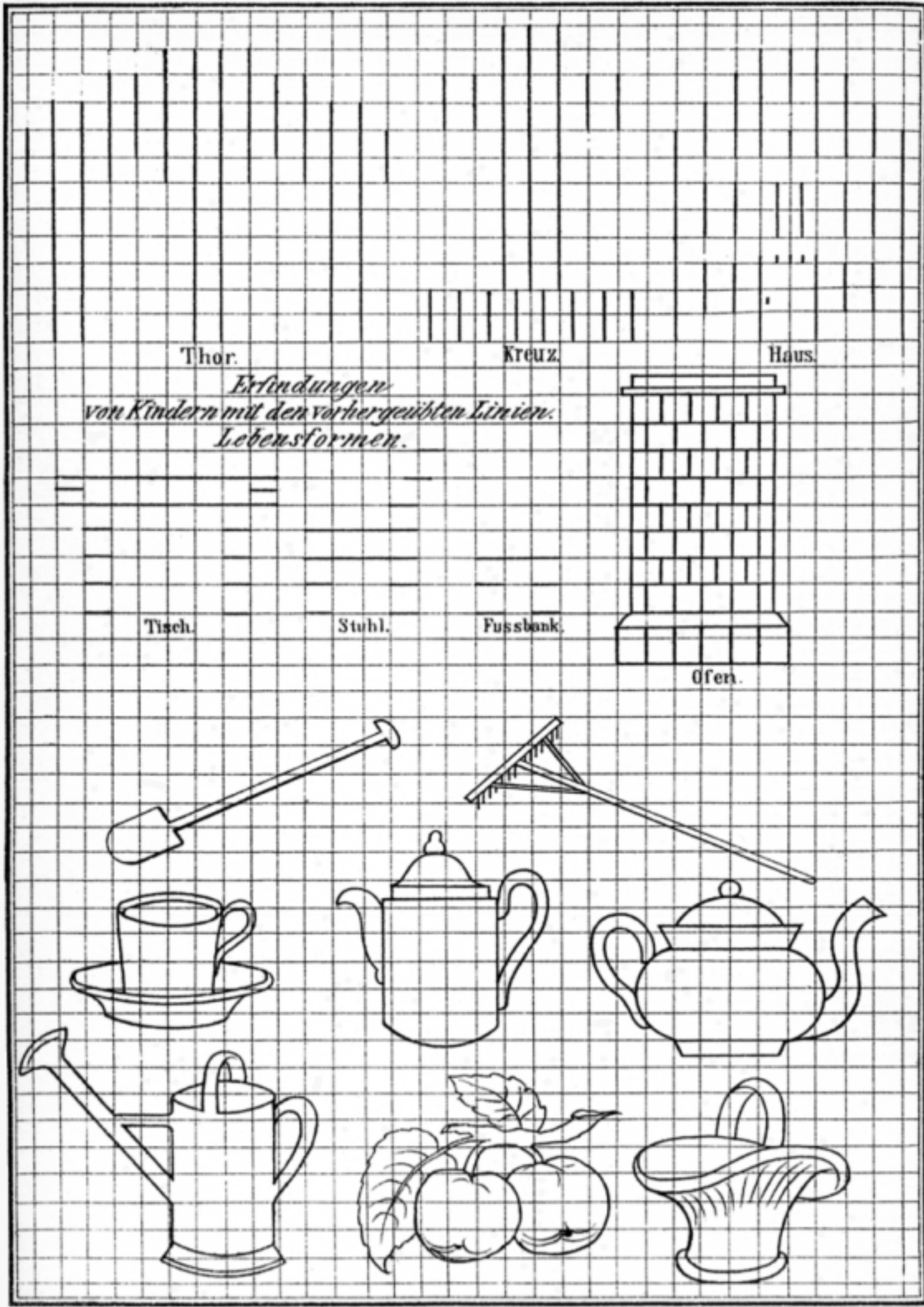

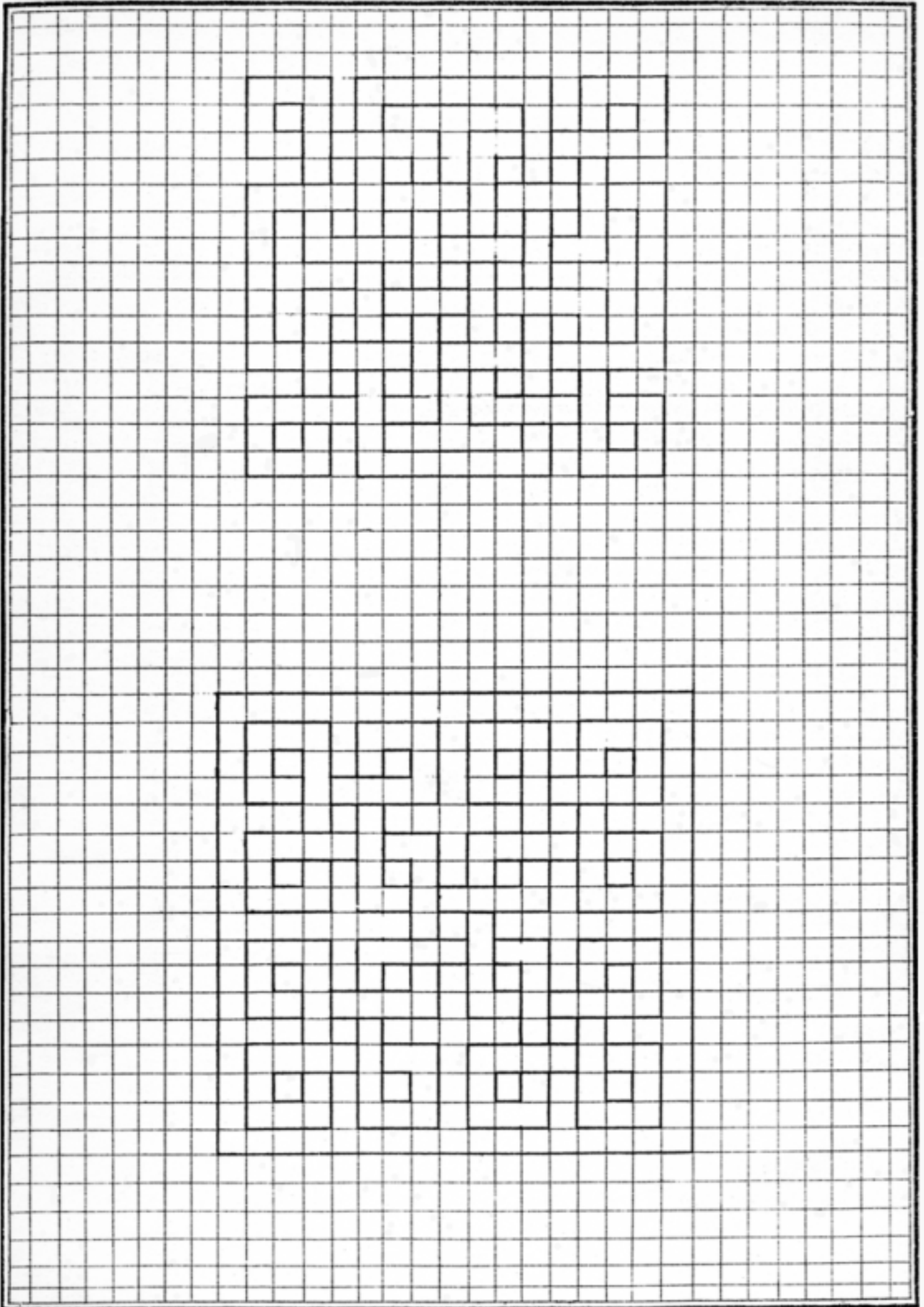

*Erfindungen.
Schönheitsformen.*

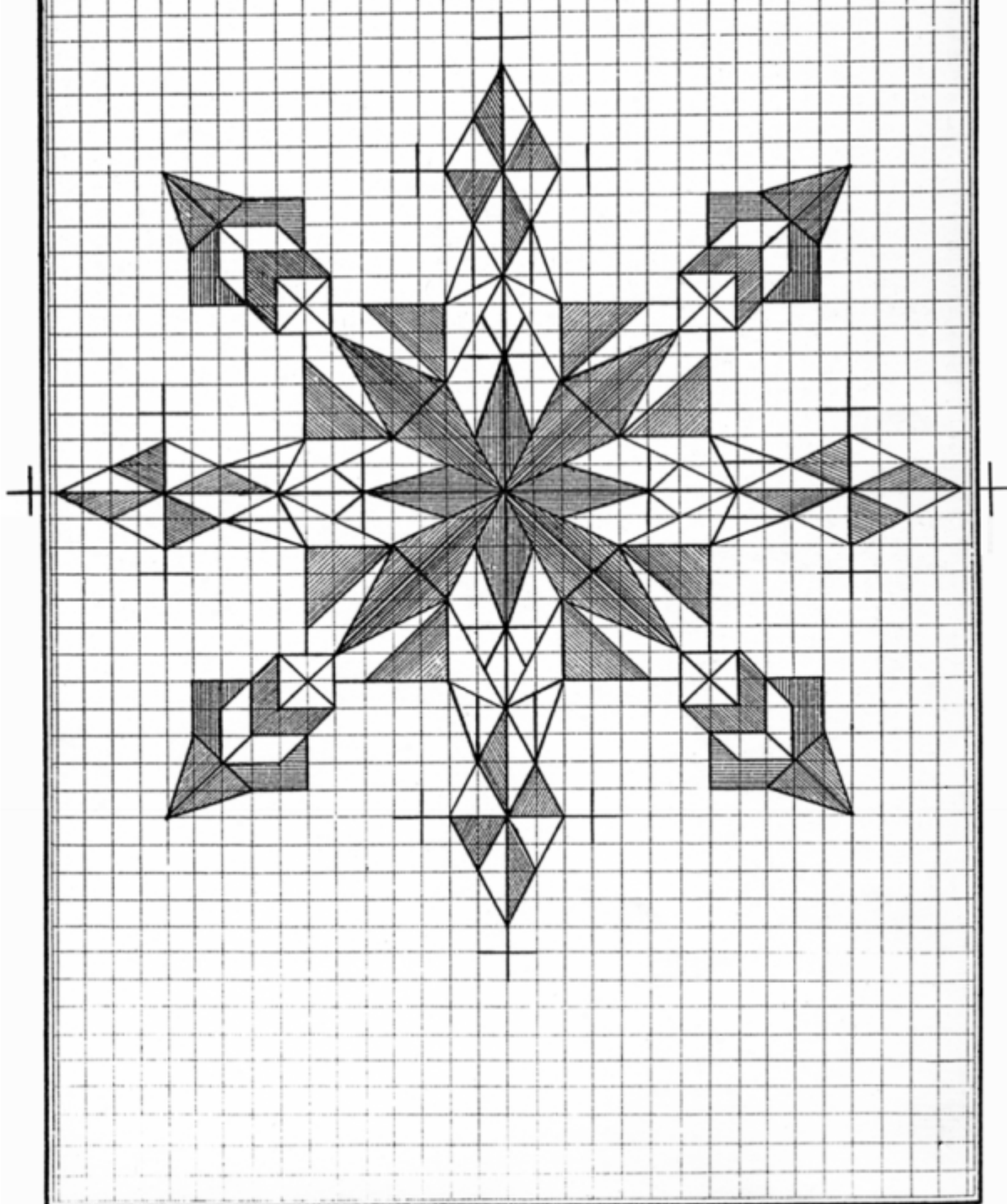

*Erfindungen.
Schönheitsformen.*

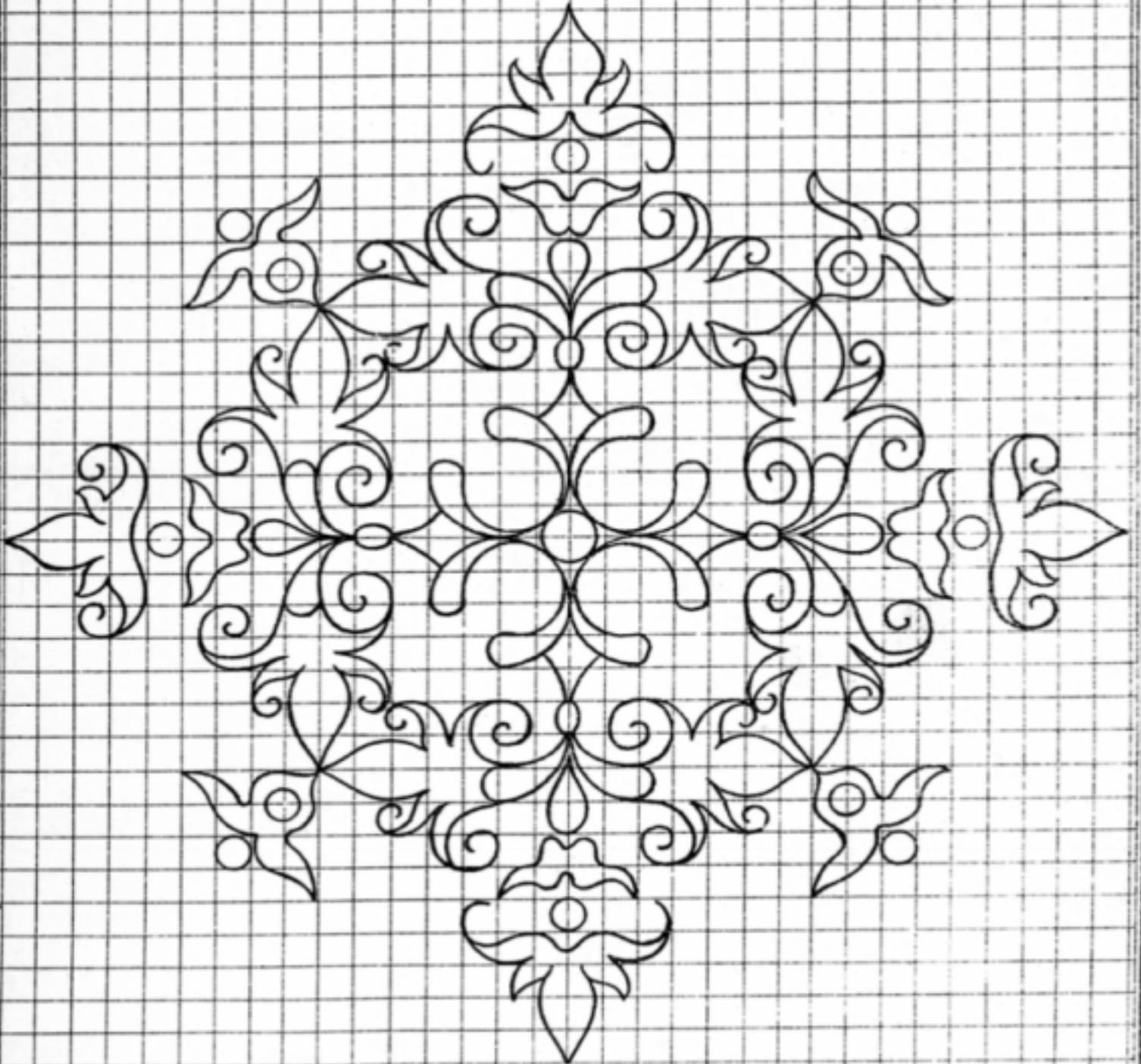

*Erfindungen.
Schönheitsformen.*

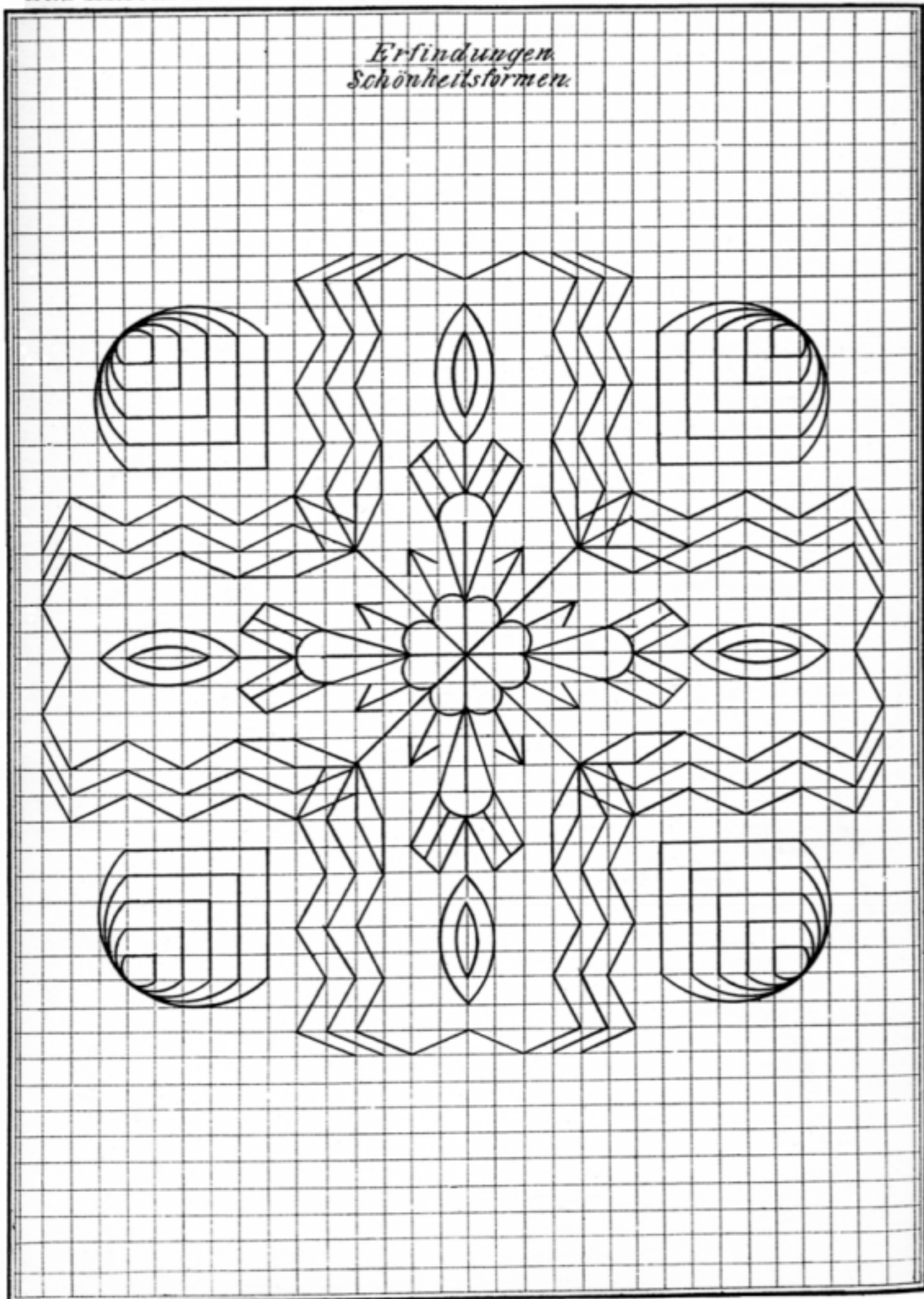

*Erfindungen
Schönheitsformen.*

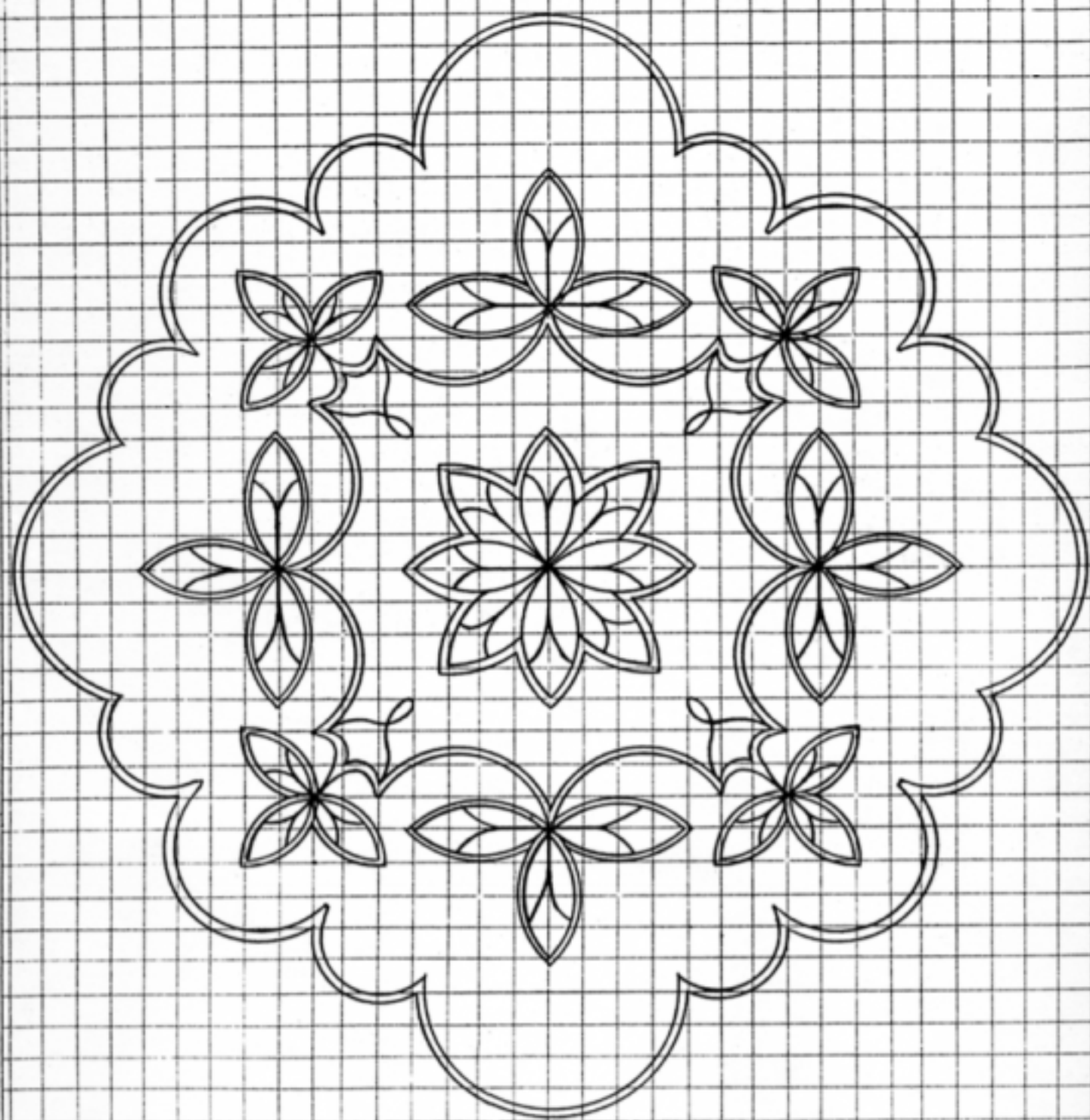

1 Erkenntnisformen u. Lebensformen zugleich.

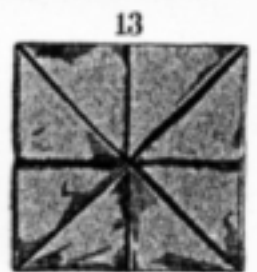
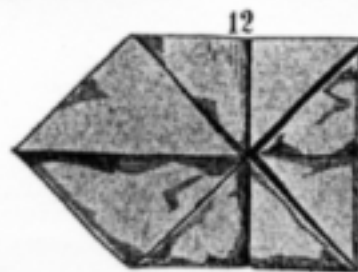
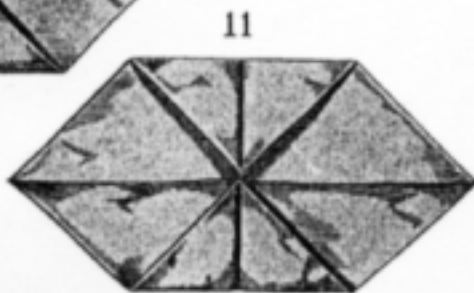
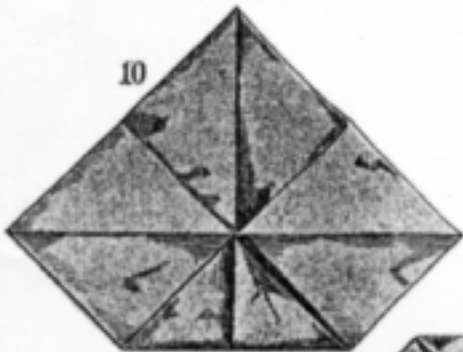
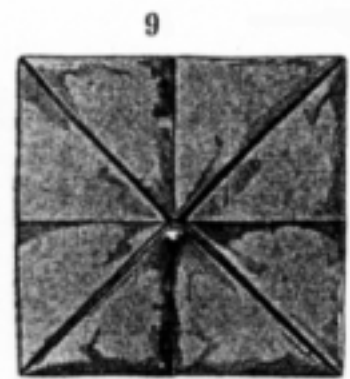
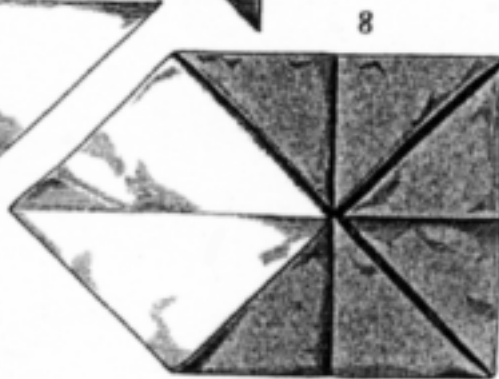
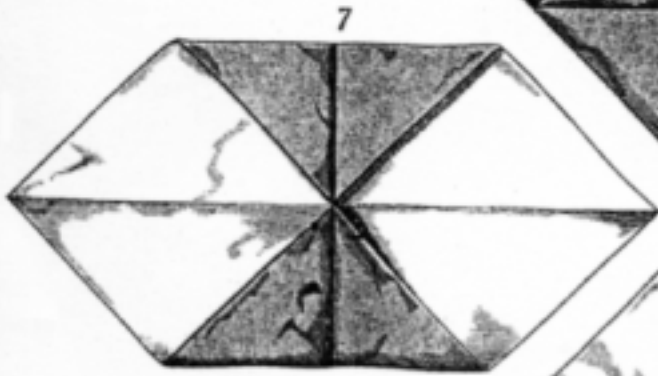
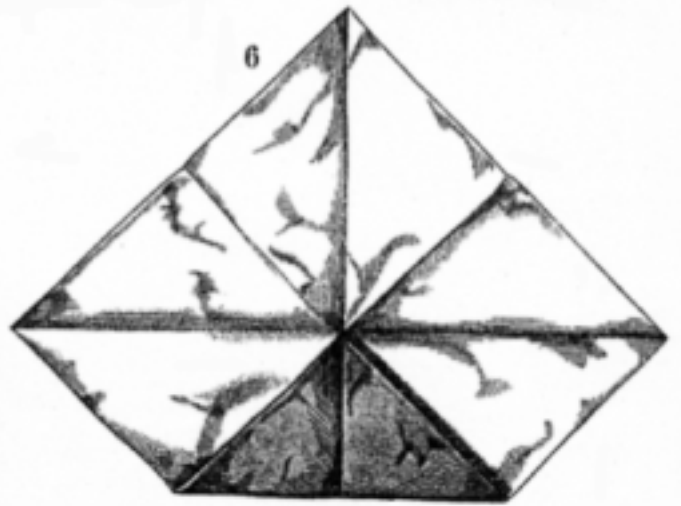
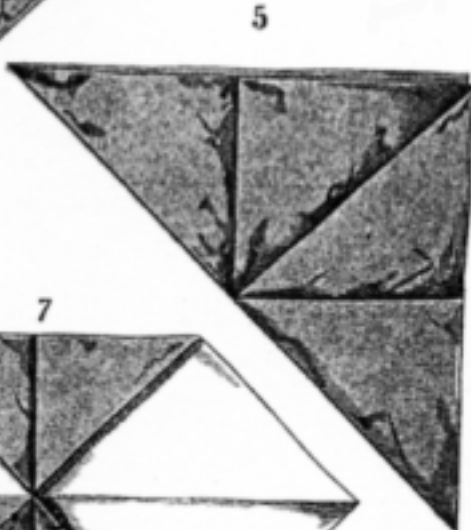
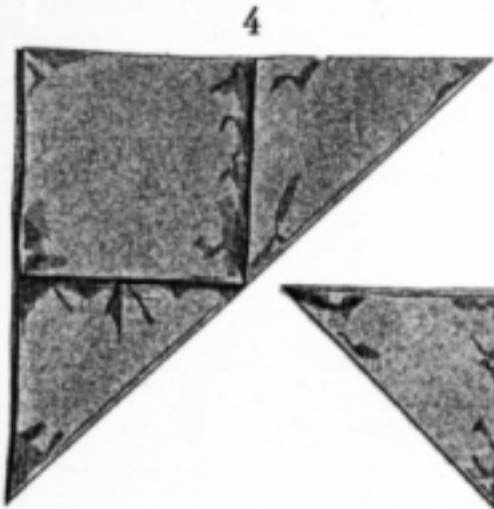
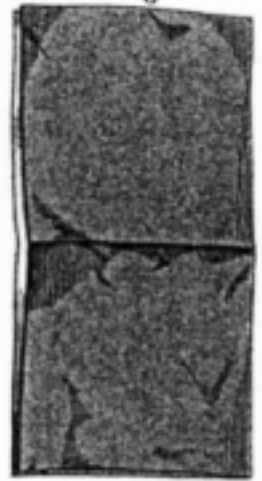
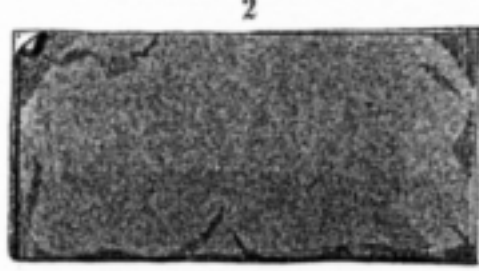

Schönheitsformen.

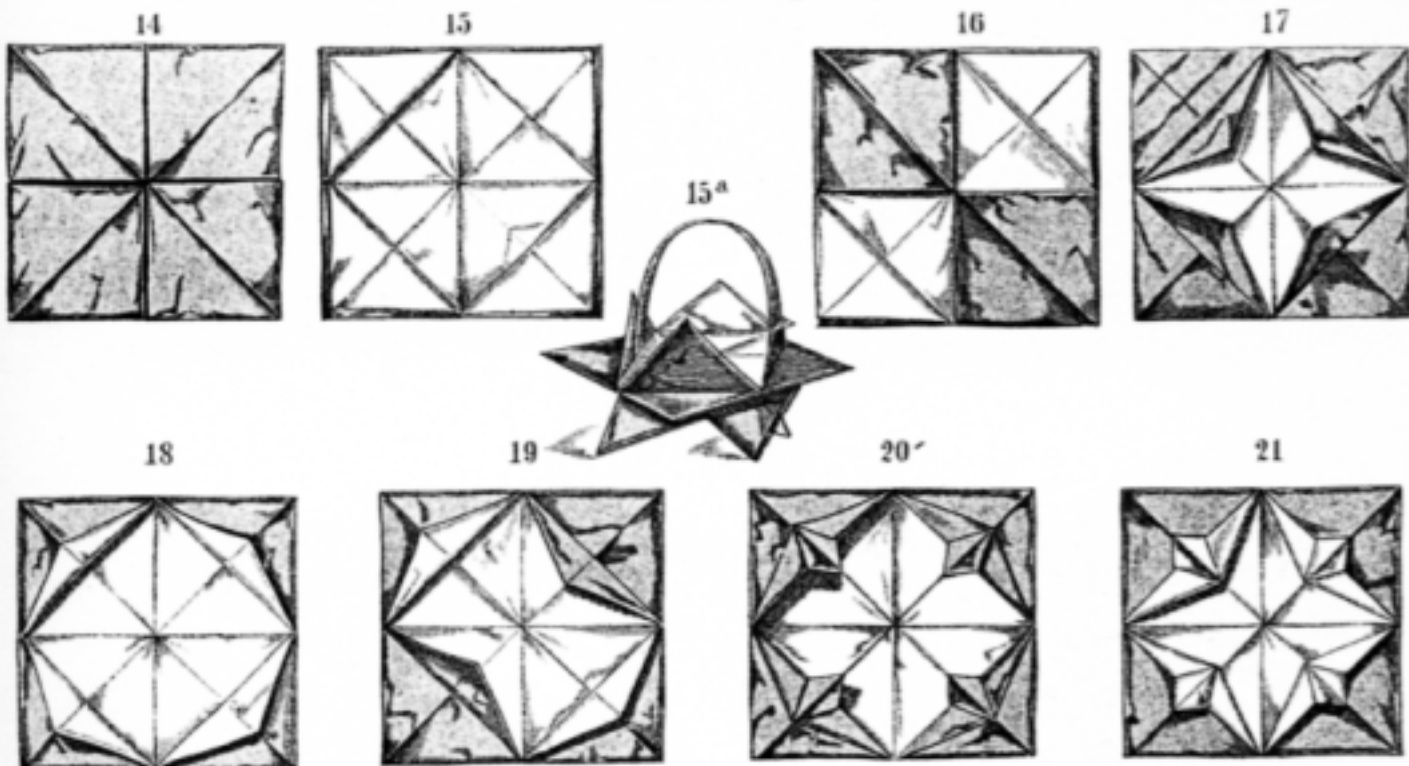

Lebensformen.

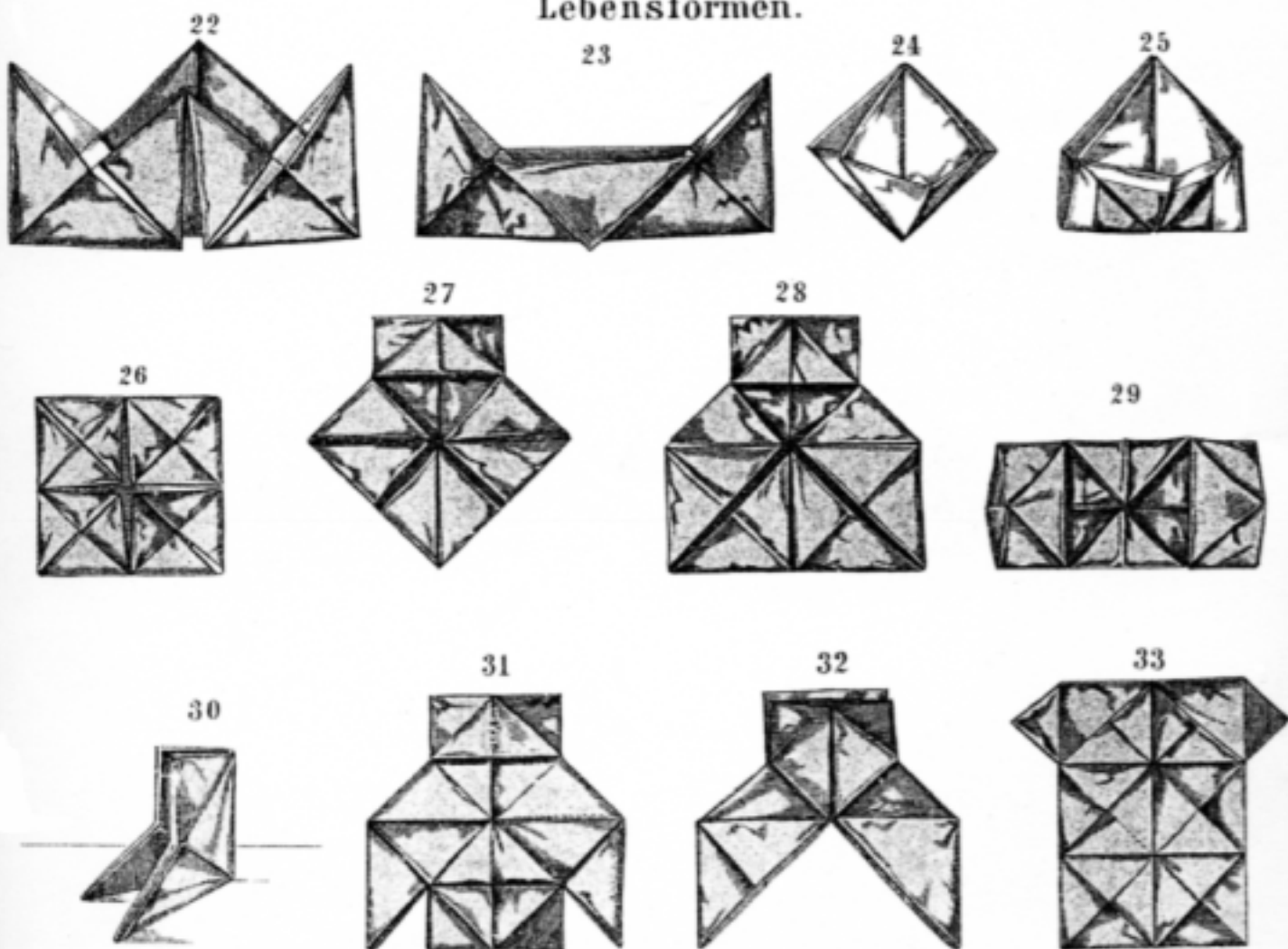

Lebensformen.

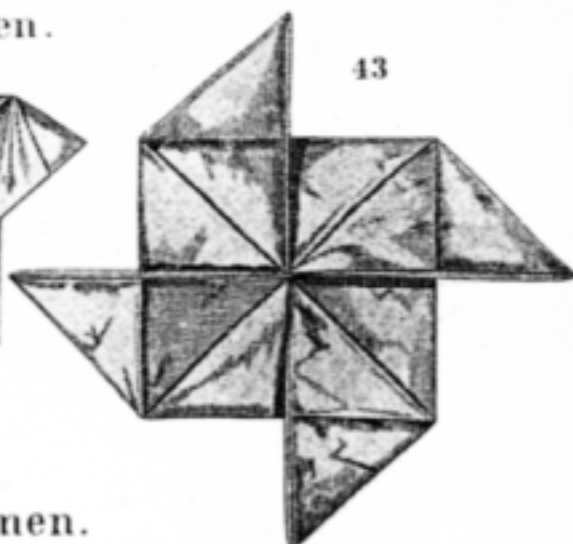
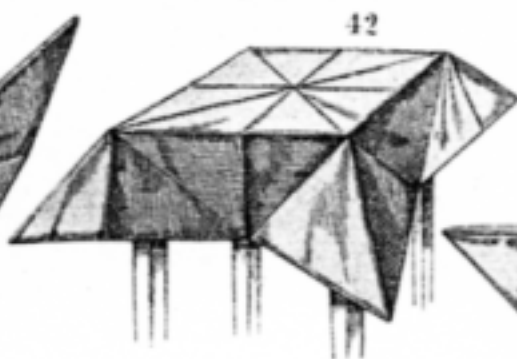
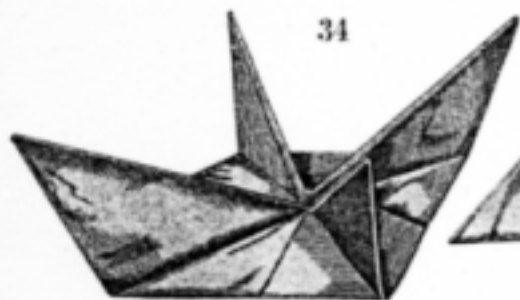

Schönheitsformen.

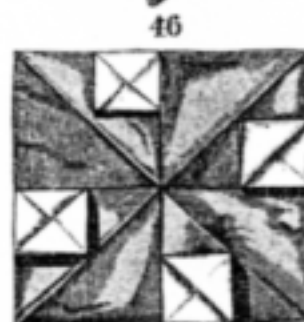
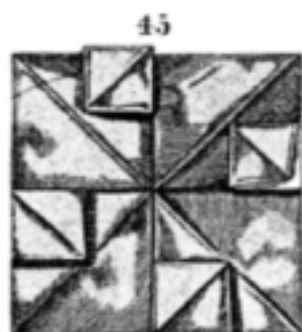
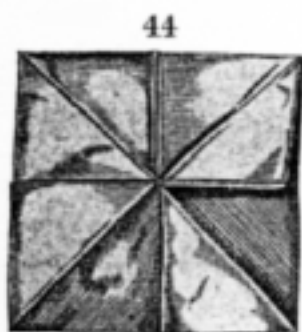

Lebensformen.

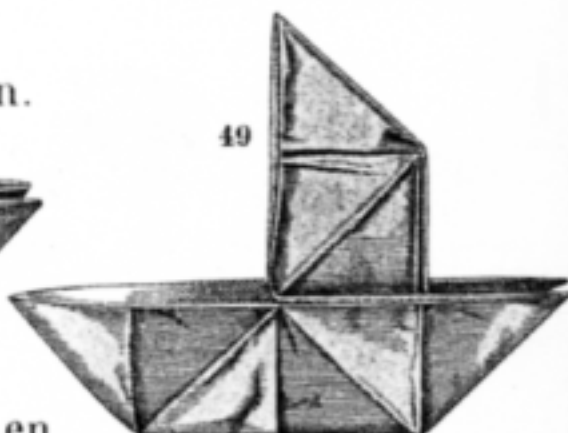
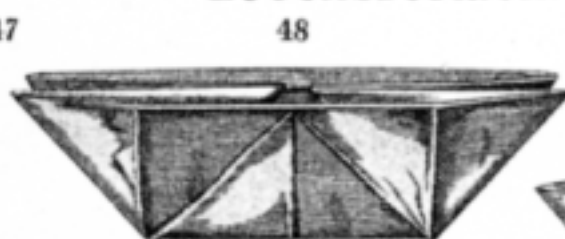
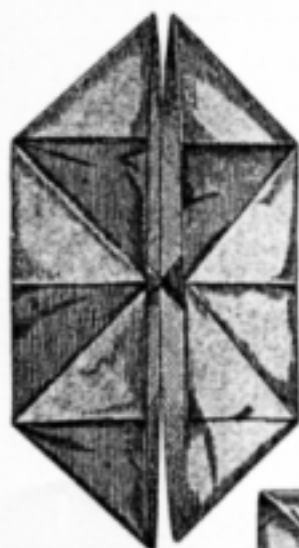

Schönheitsformen.

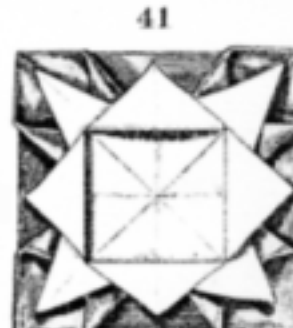
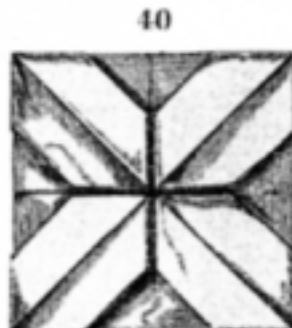
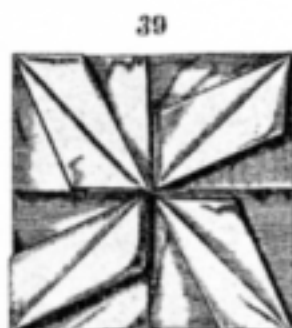
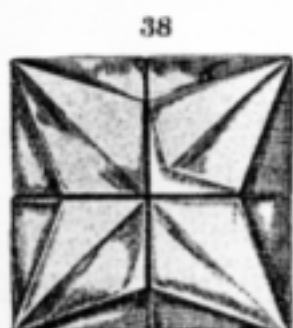
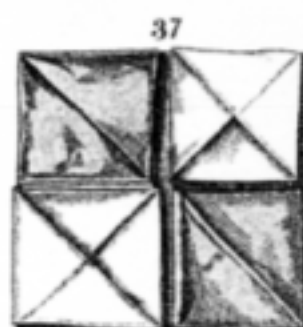
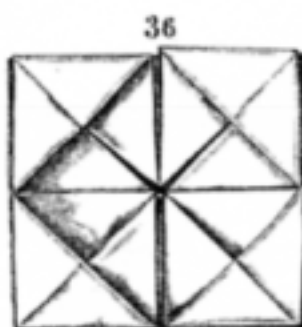
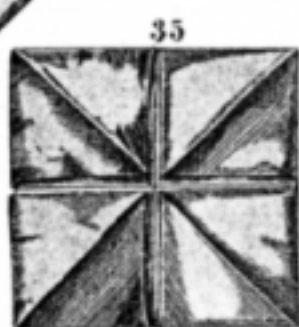

Die Flechtschule.

Tafel I.

1.

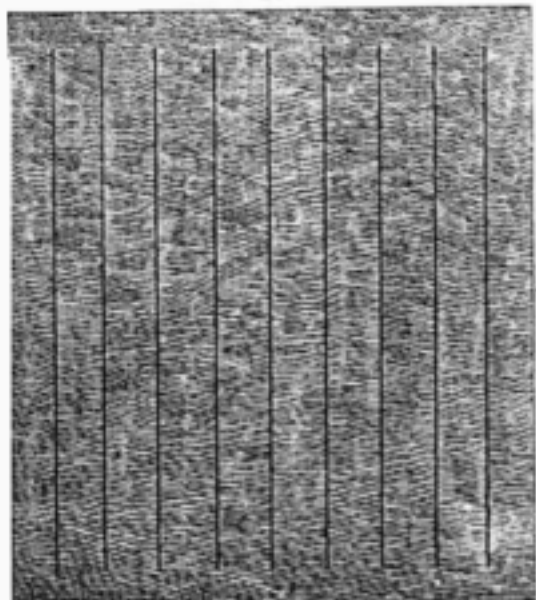

2.

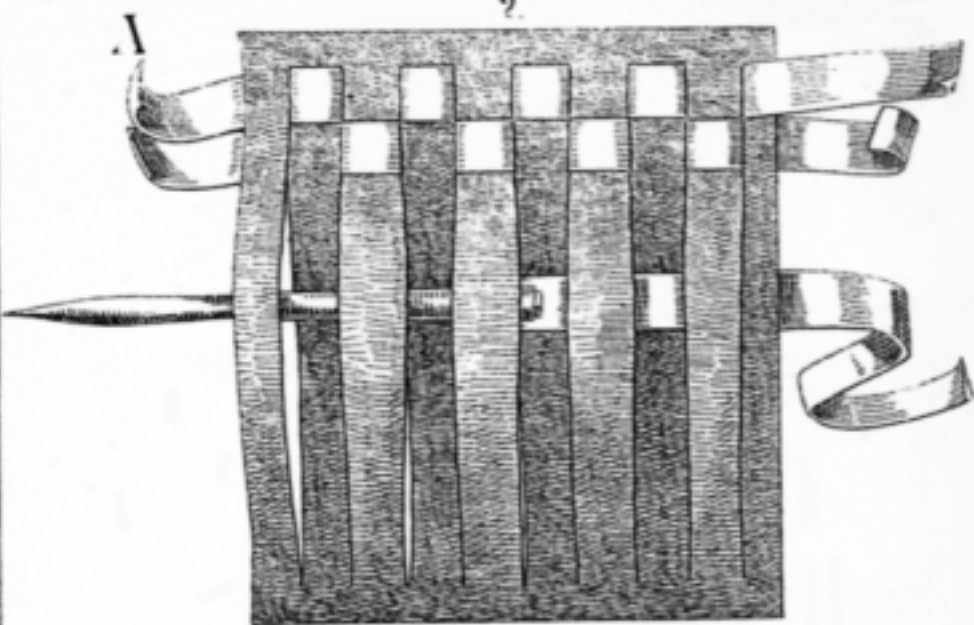

B

1. Satz.

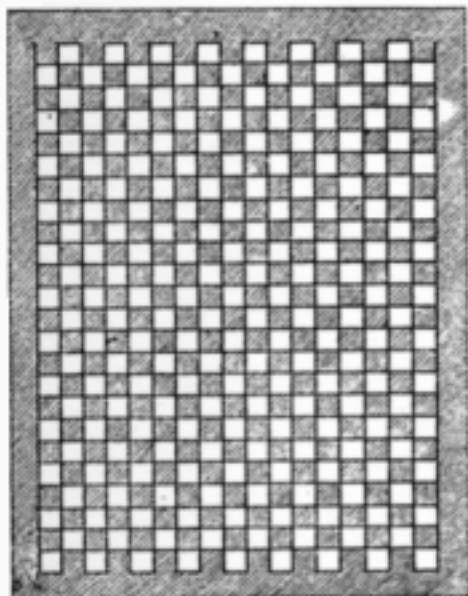

2. Gegensatz.

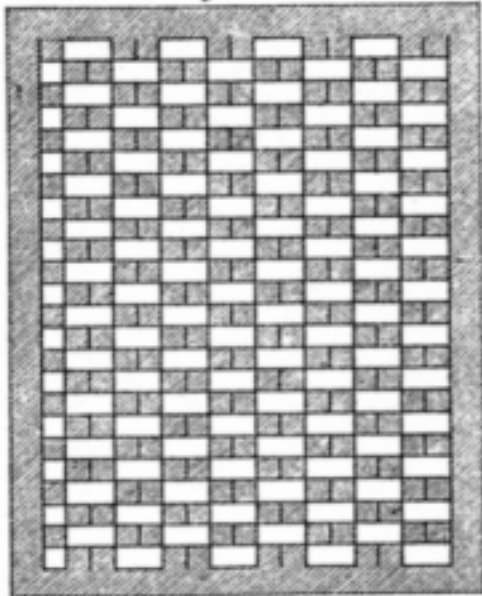

3. Verknüpfung.

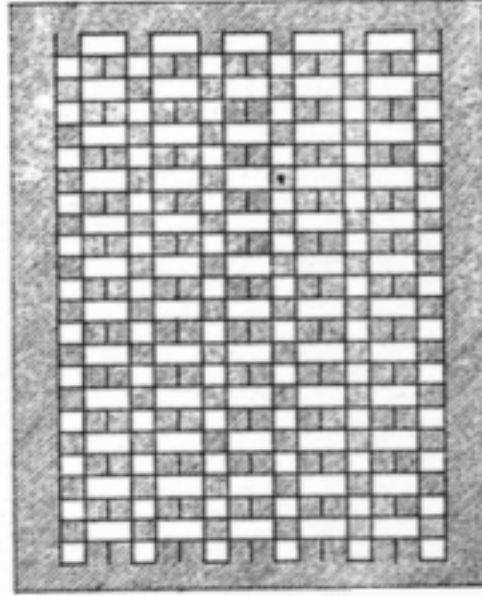

4. Satz.

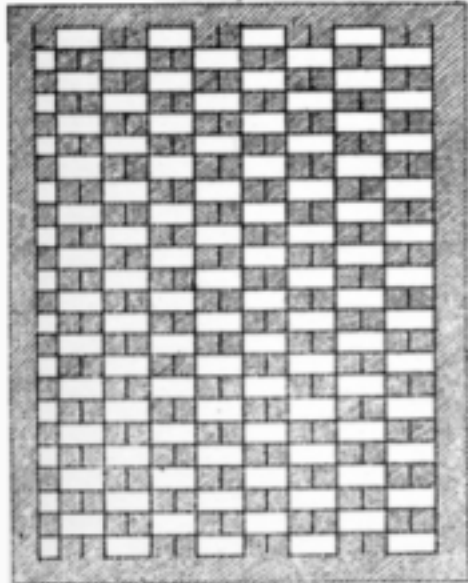

5. Gegensatz.

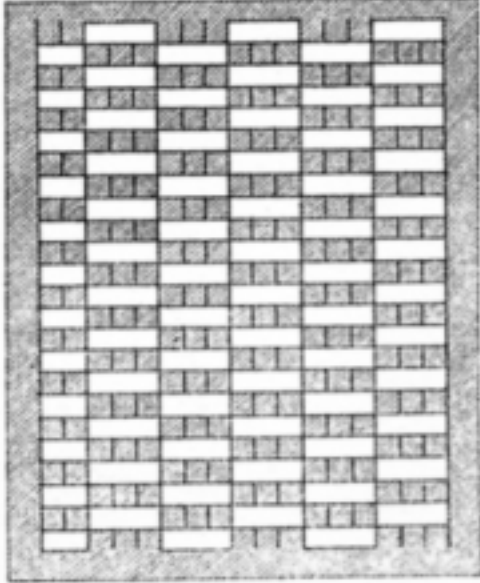

6. Verknüpfung.

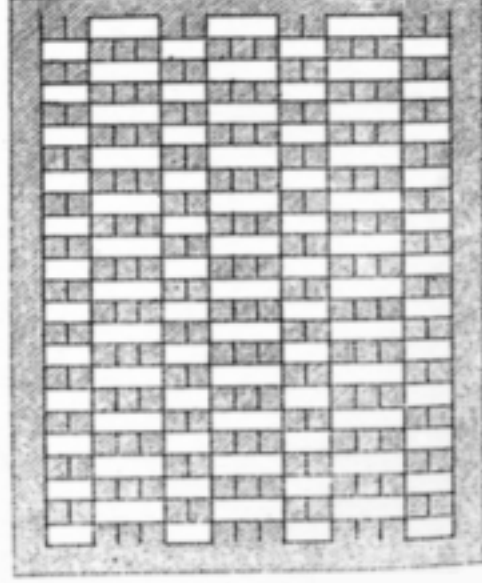

A

1.

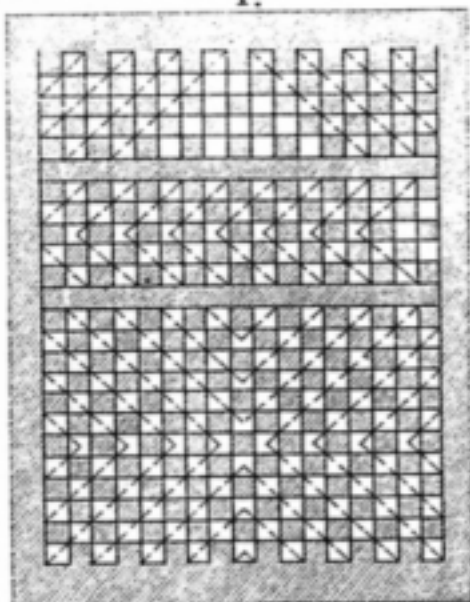

2.

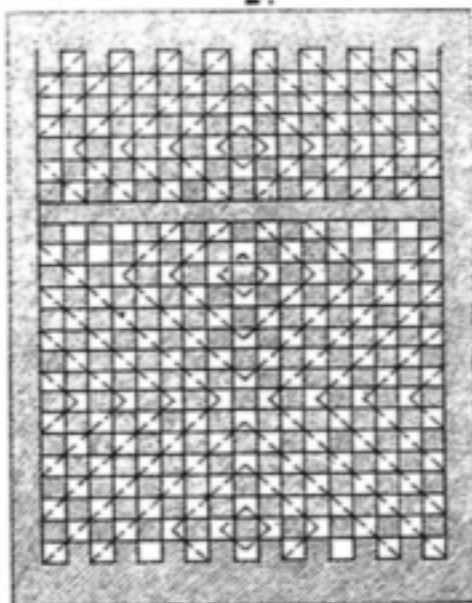

B

7. Satz.

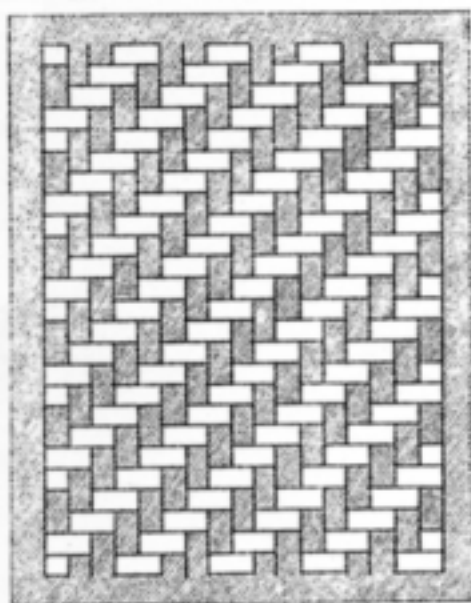

8. Gegensatz.

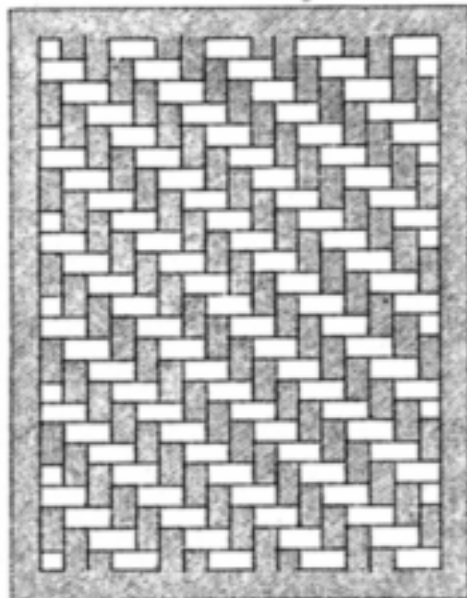

9. Verknüpfung.

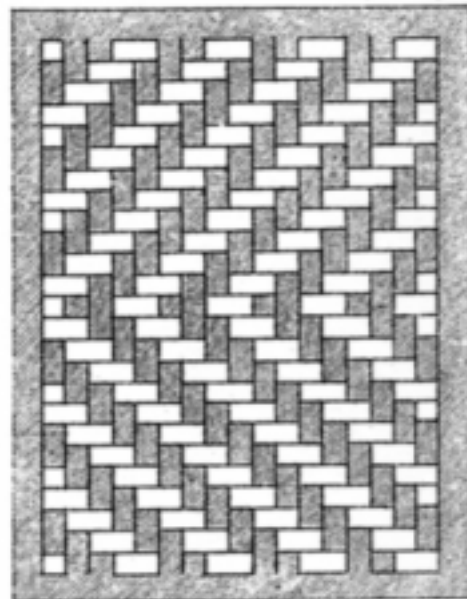

10. Satz.

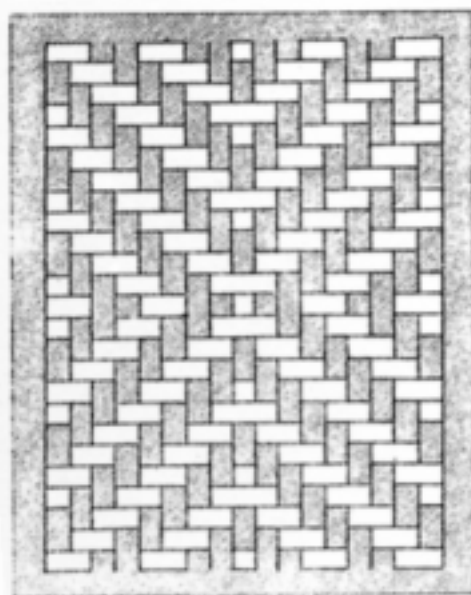

11. Gegensatz.

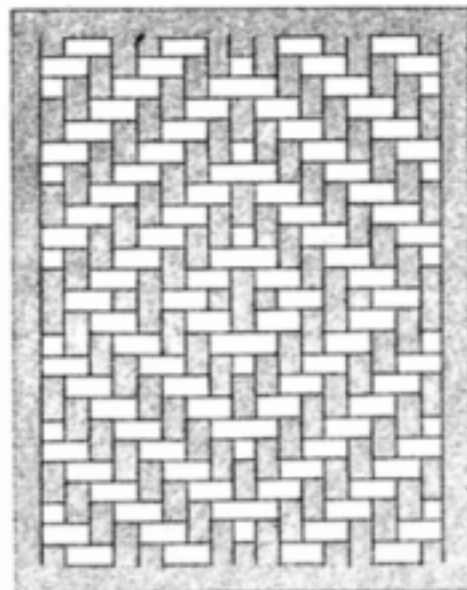

12. Verknüpfung.

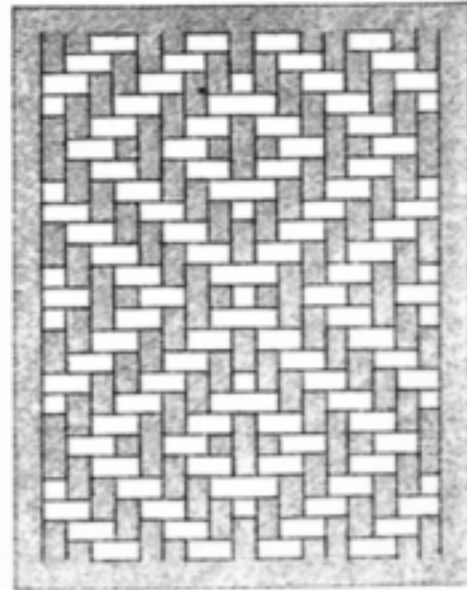

Das Flechten.

1.

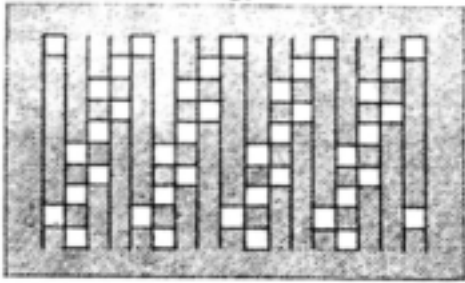

4.

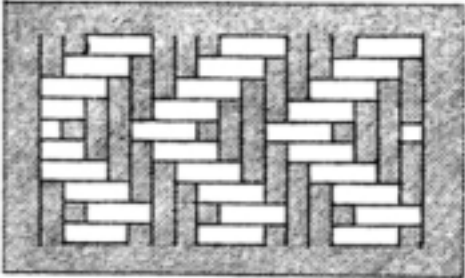

A

1.

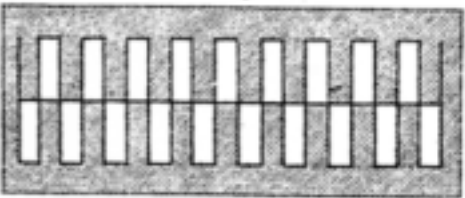

2.

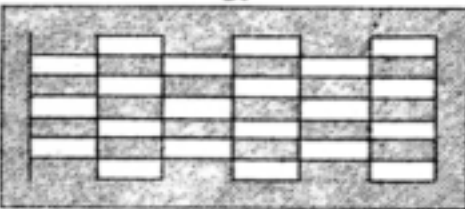

3.

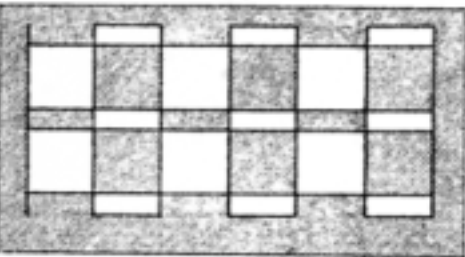

Vermittlungsformen.

2.

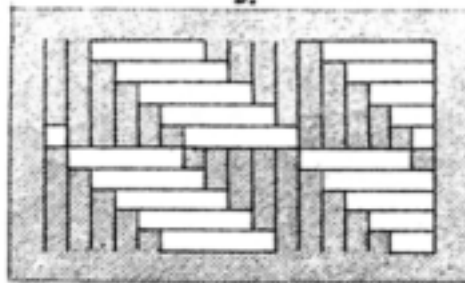

5.

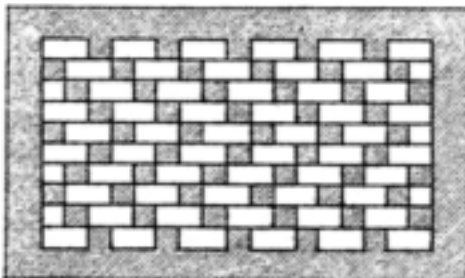

B

Muster von 1 auf, 1 nieder.

1.

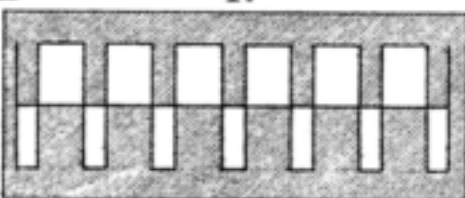

2.

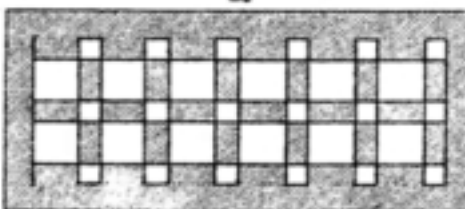

3.

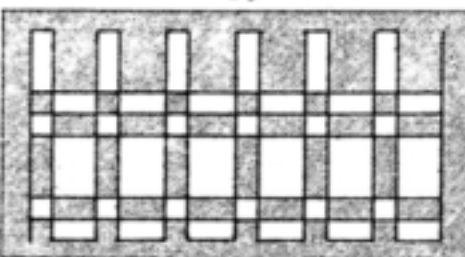

Tafel III.

3.

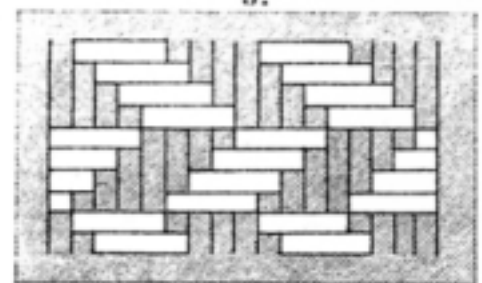

6.

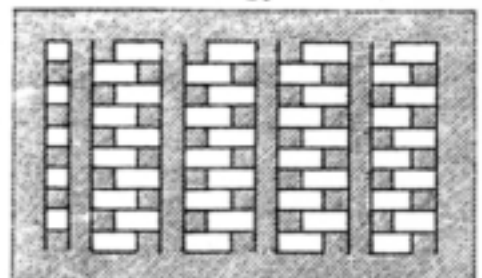

C

1.

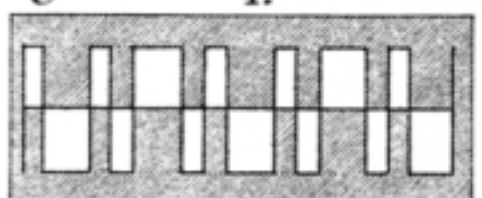

2.

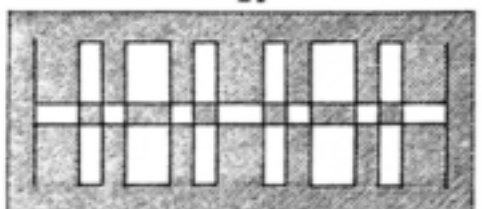

3.

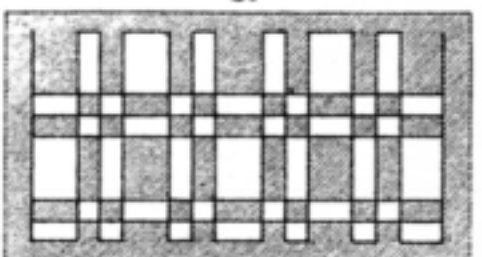

D

1.

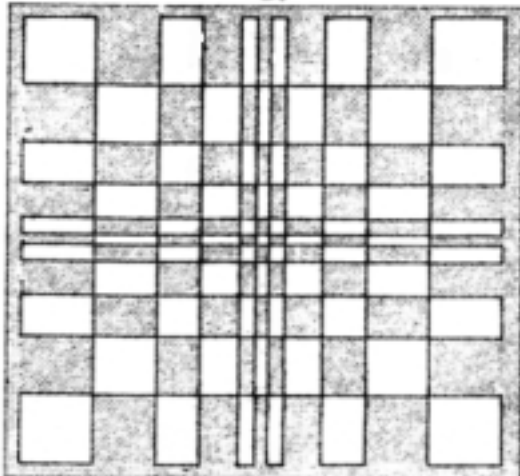

2.

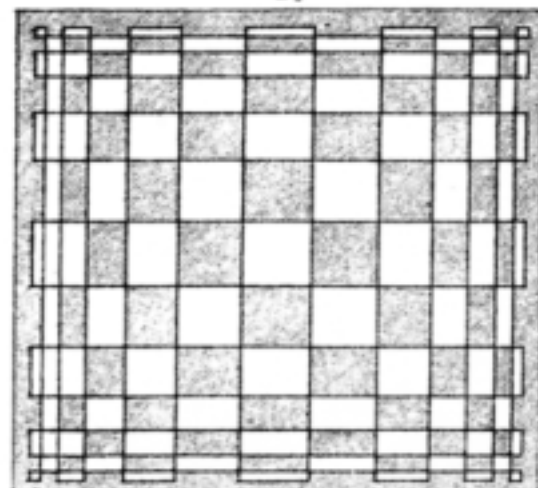

Das Flechten.

Erfindungen von Kindern.

Tafel IV.

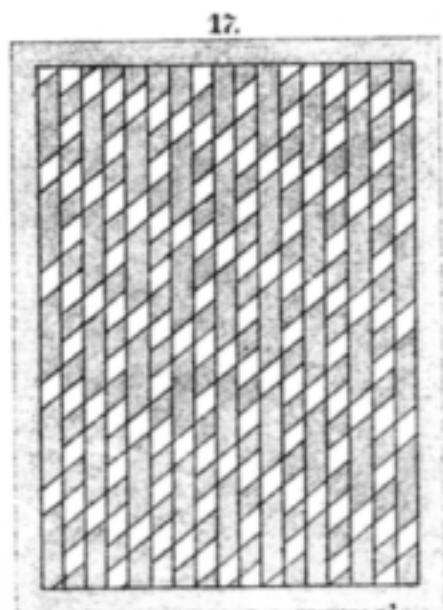
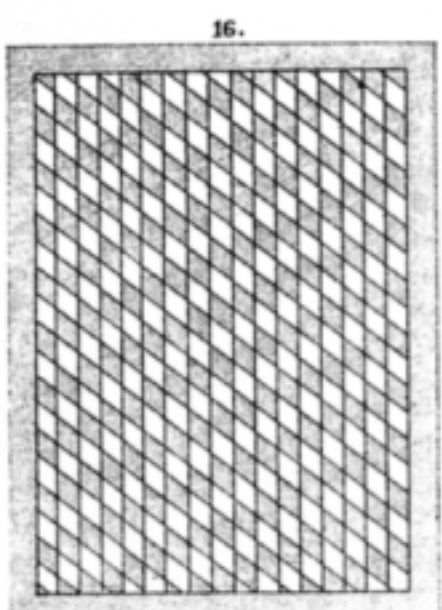
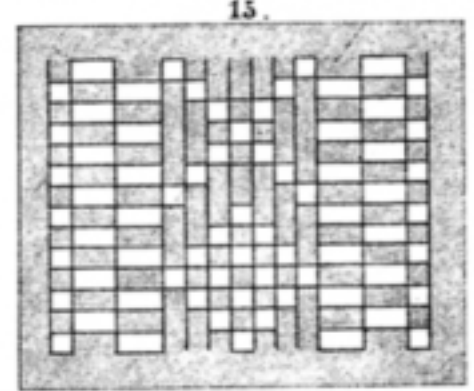
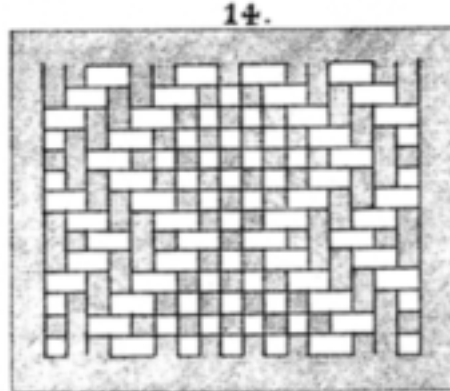
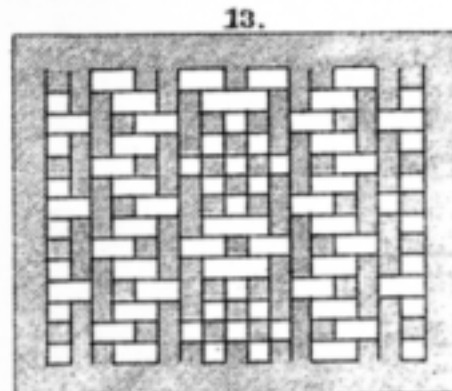
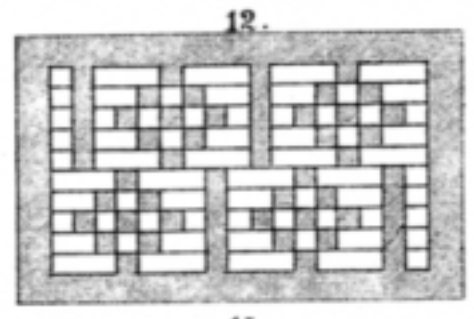
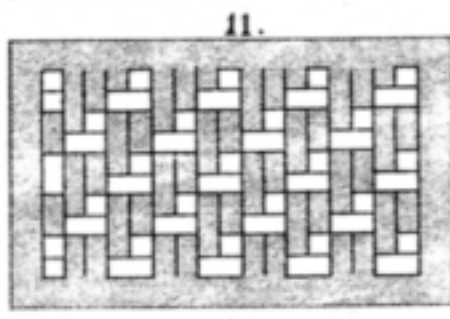
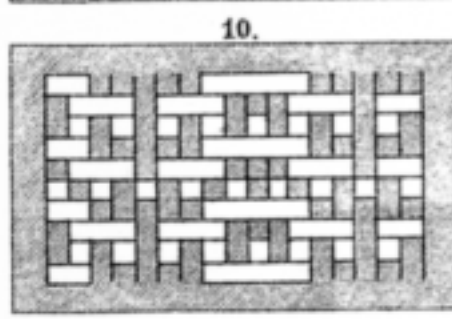
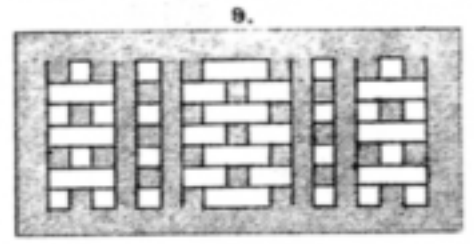
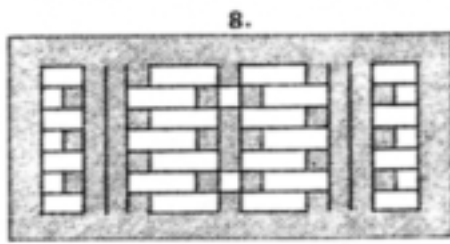
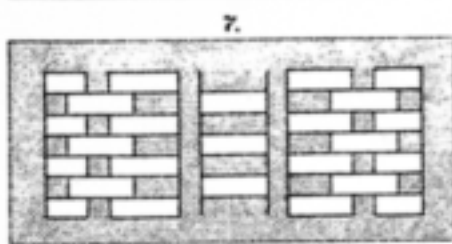
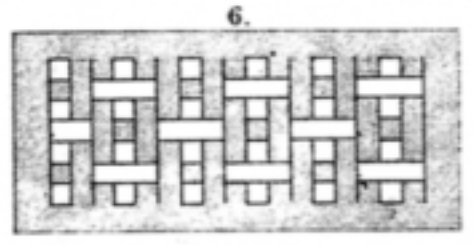
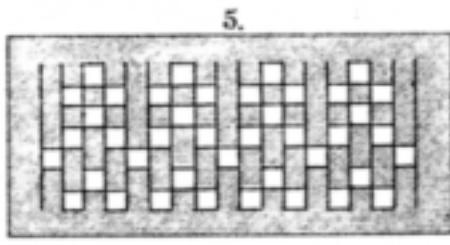
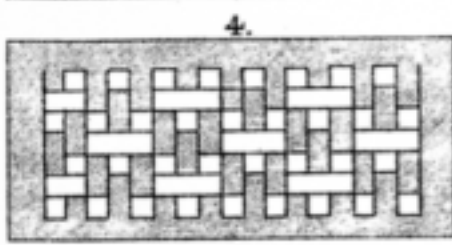
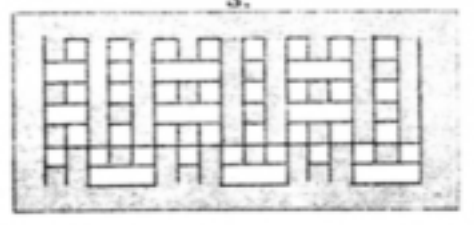
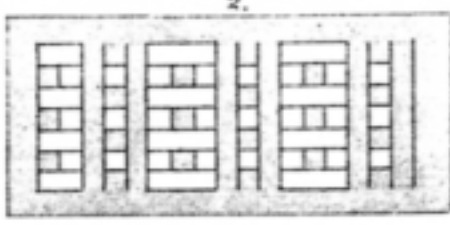
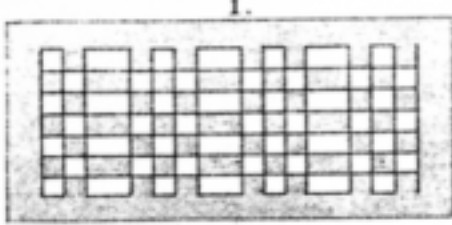

Das Flechten.

Lesezeichen 1.u.3. Art.

Tafel V.

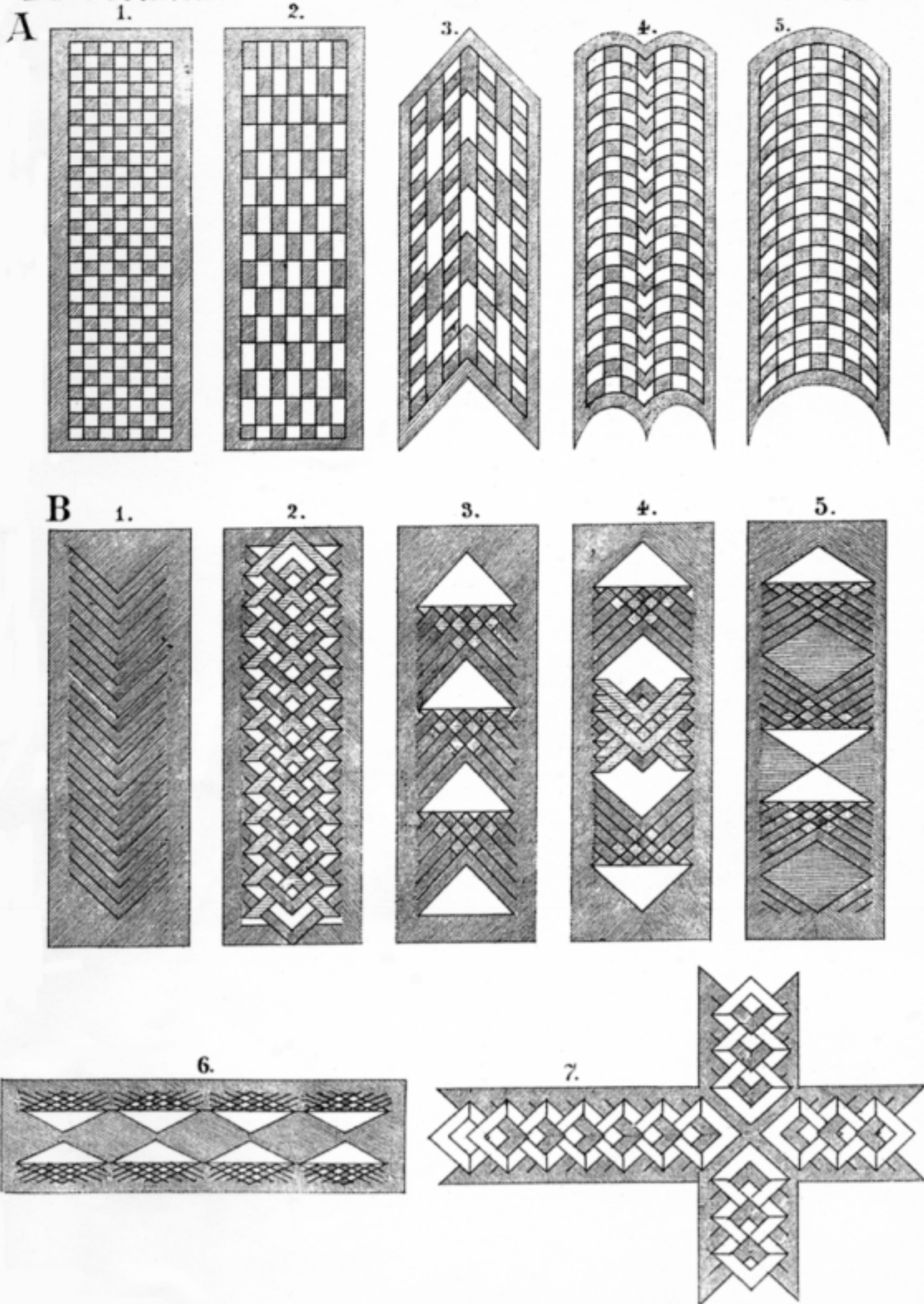

Das Flechten.

Lebens- u. Erkenntnisformen. *Bezeichnen.*

Tafel VI.

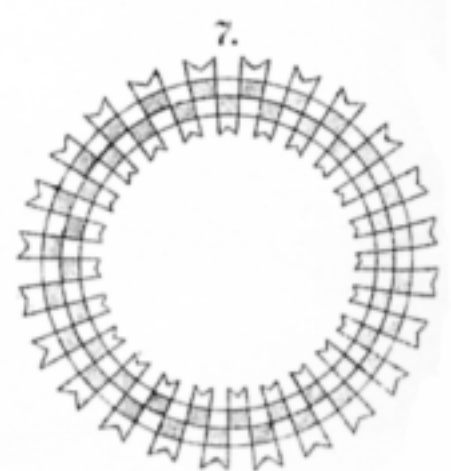
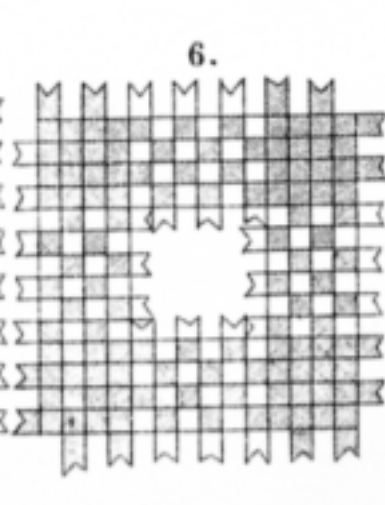
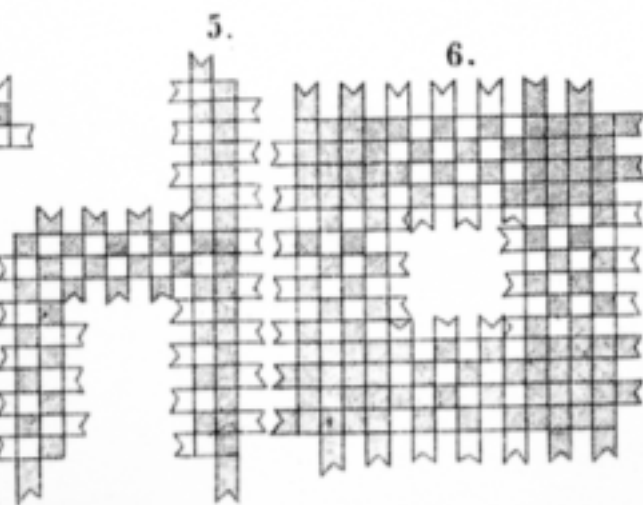
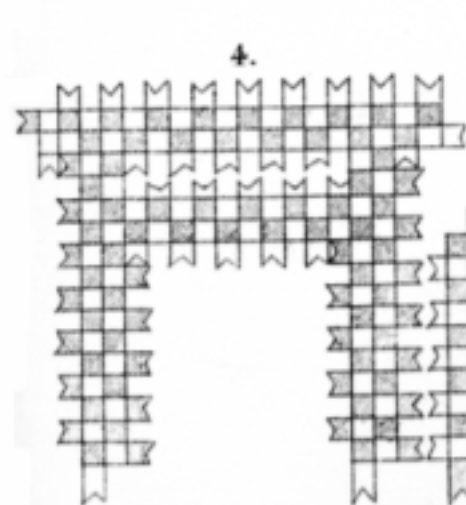
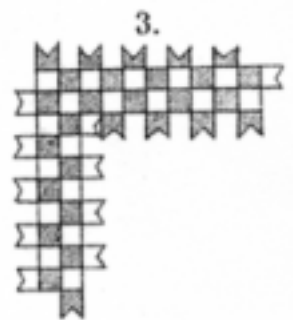
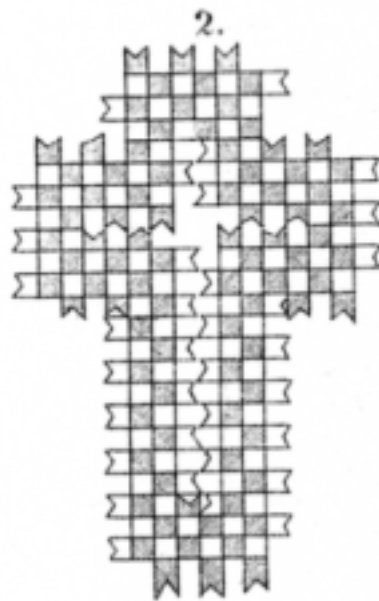
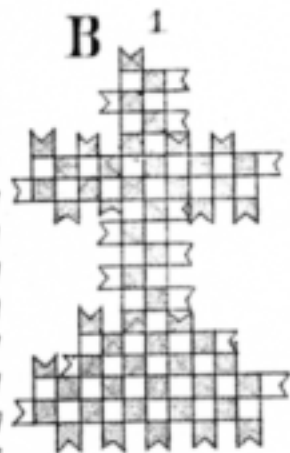
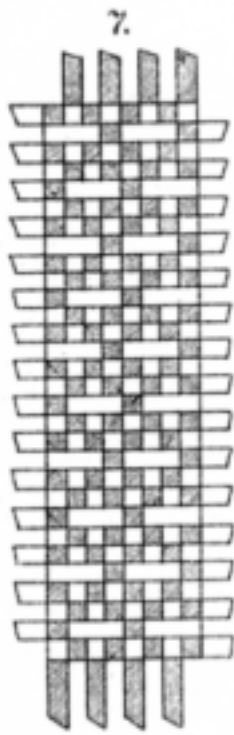
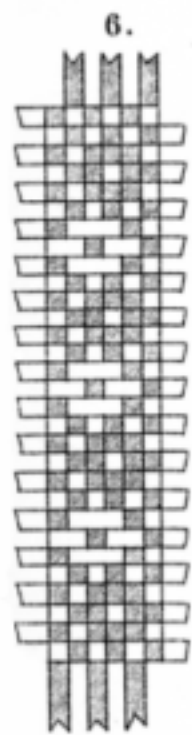
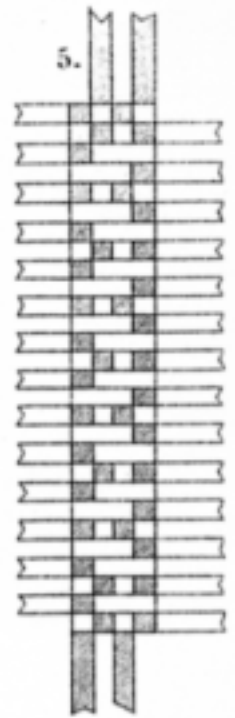
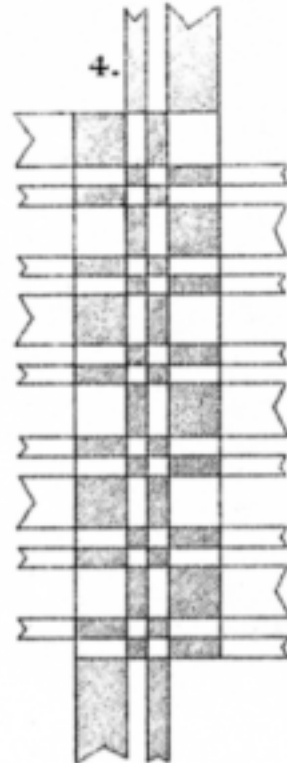
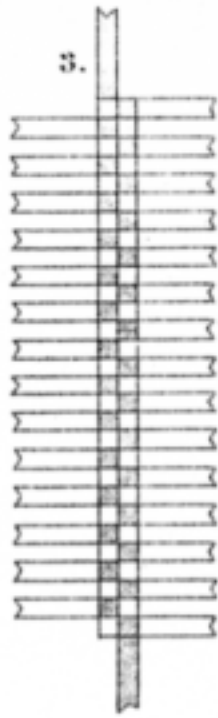
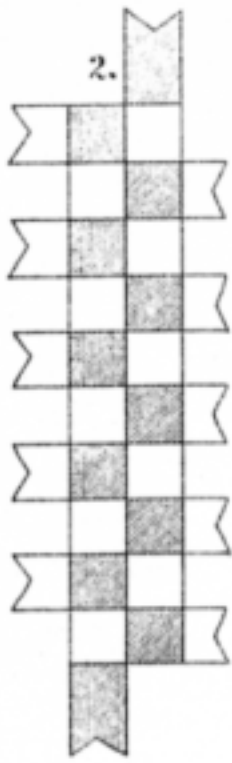
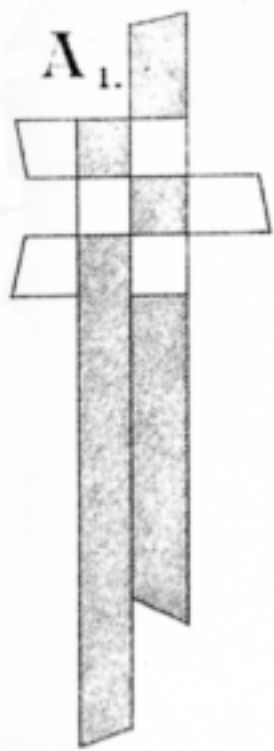

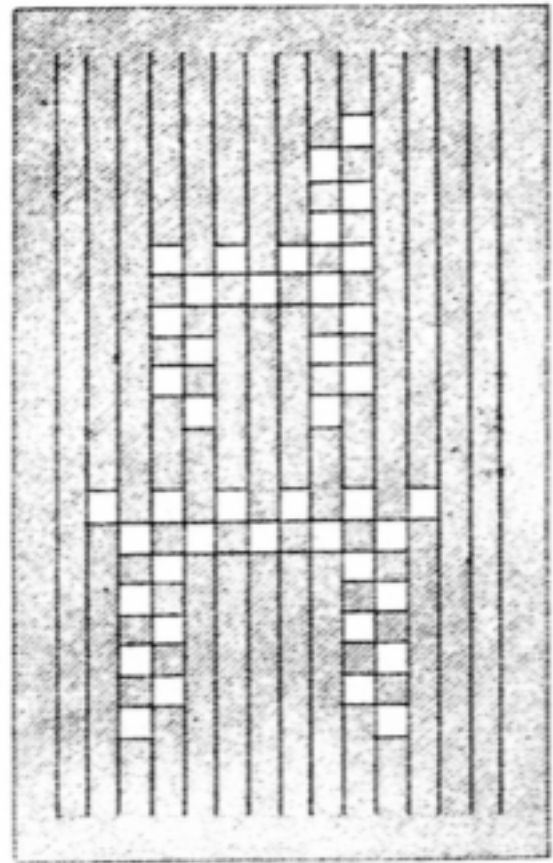
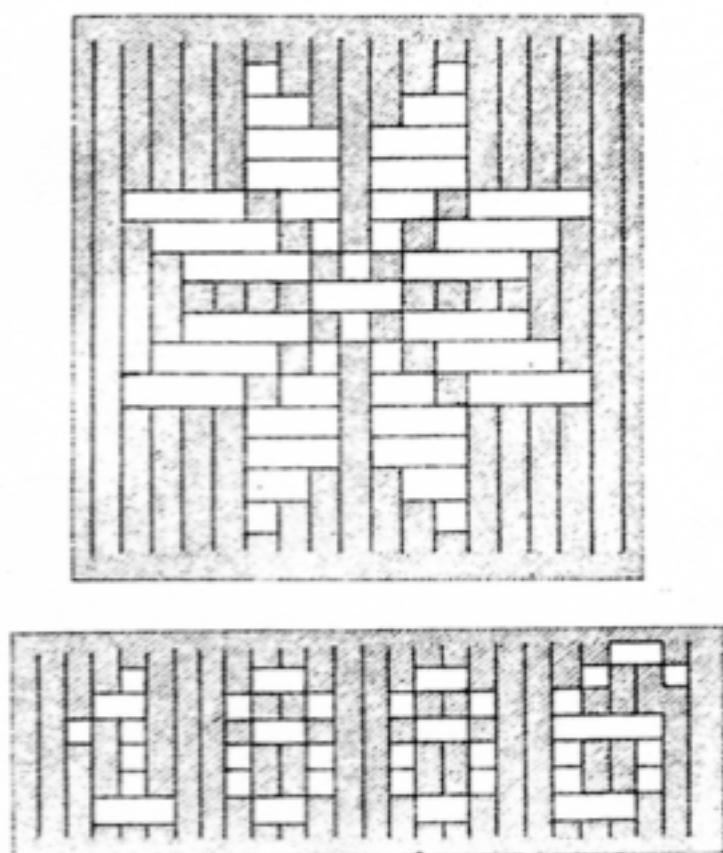
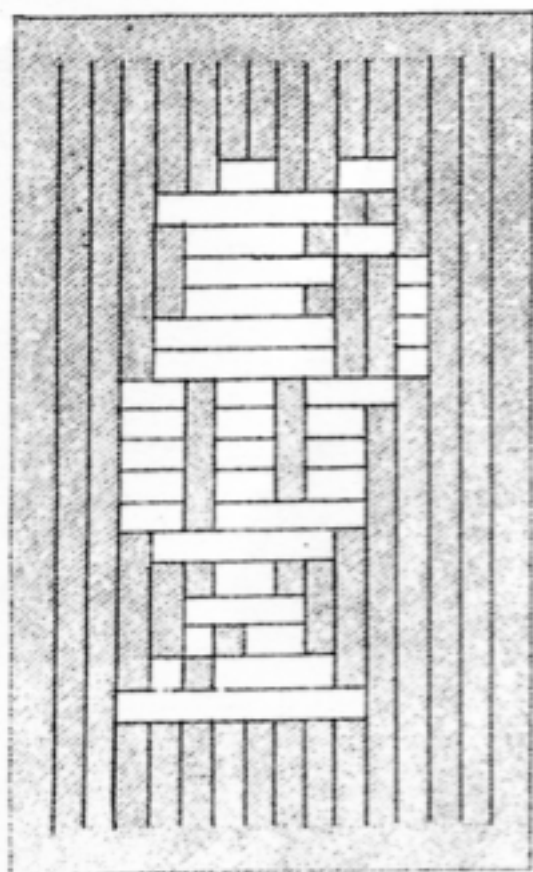
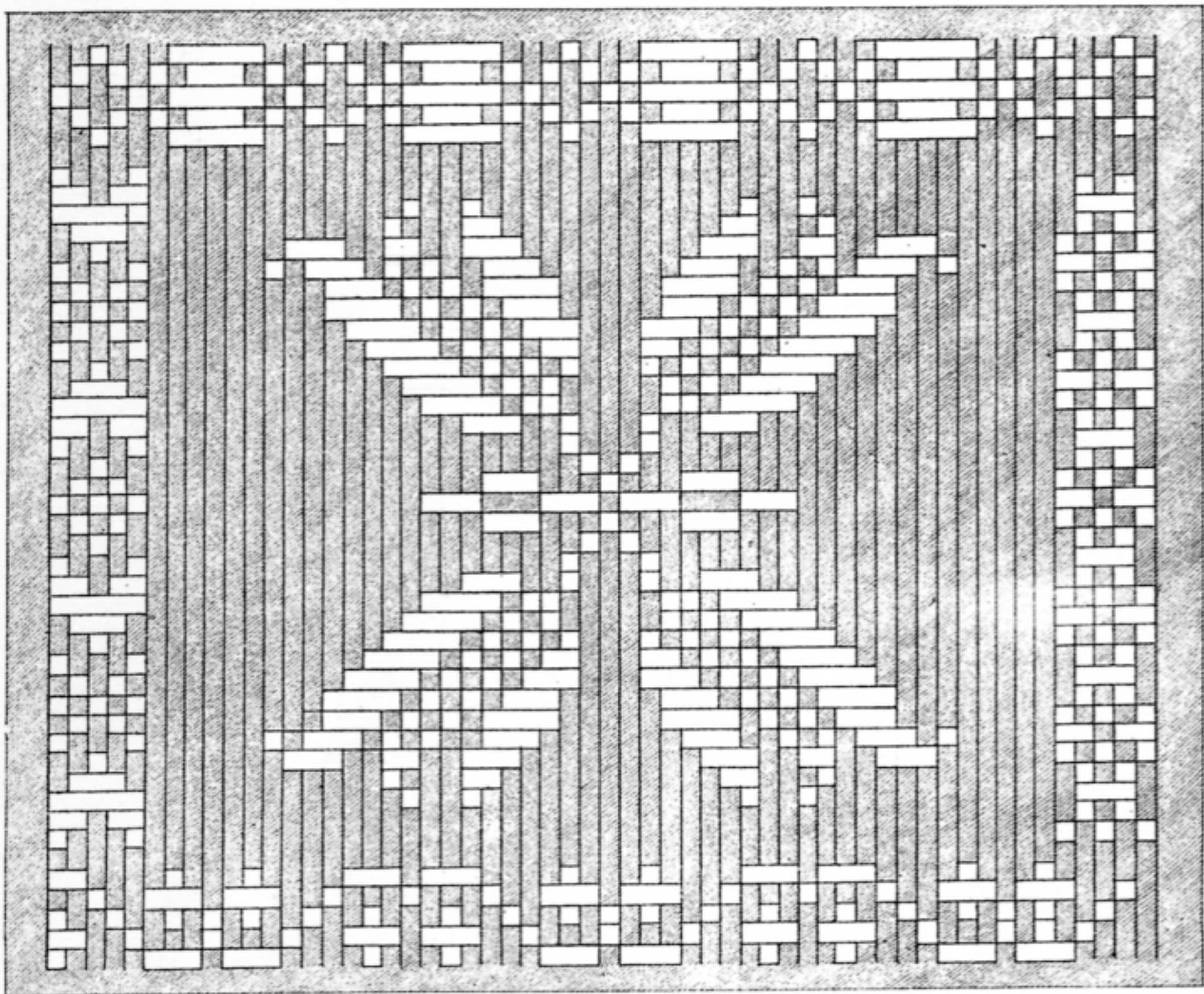
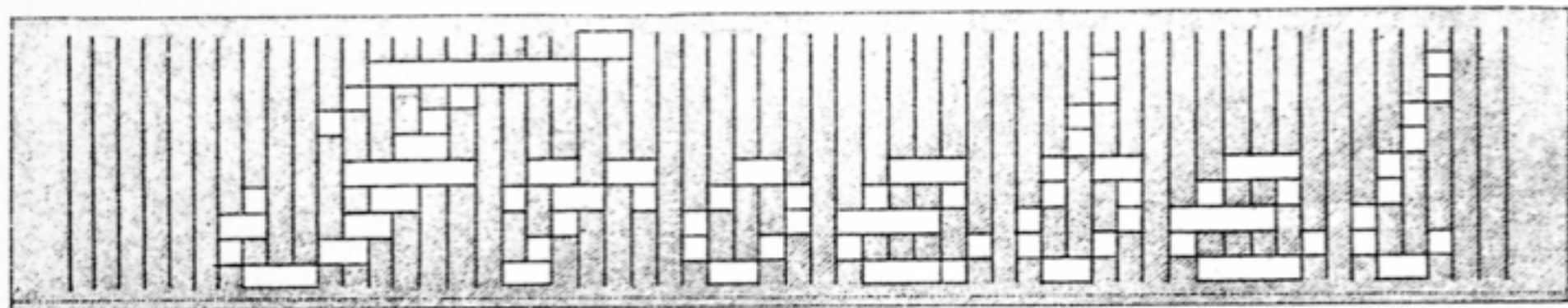

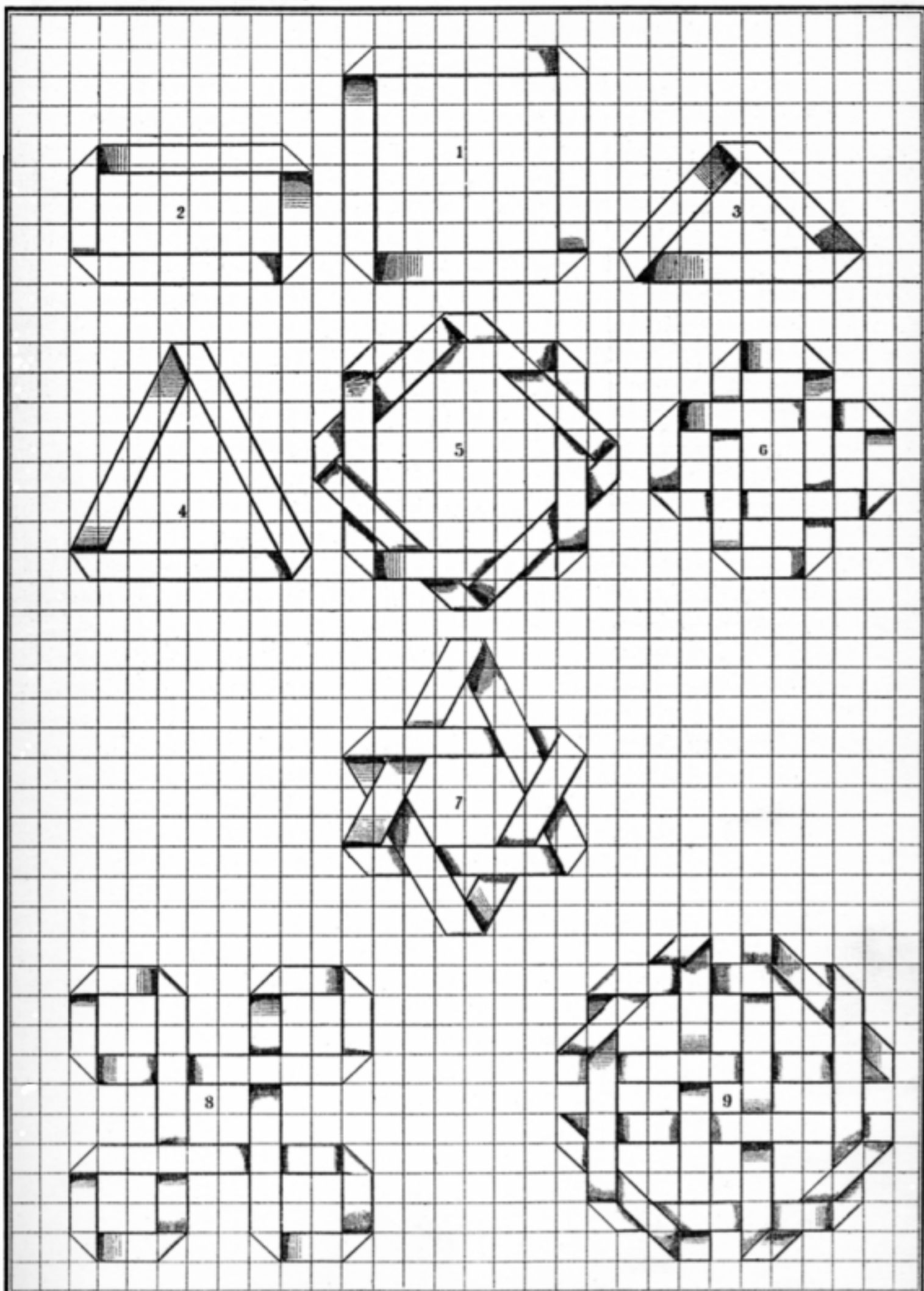

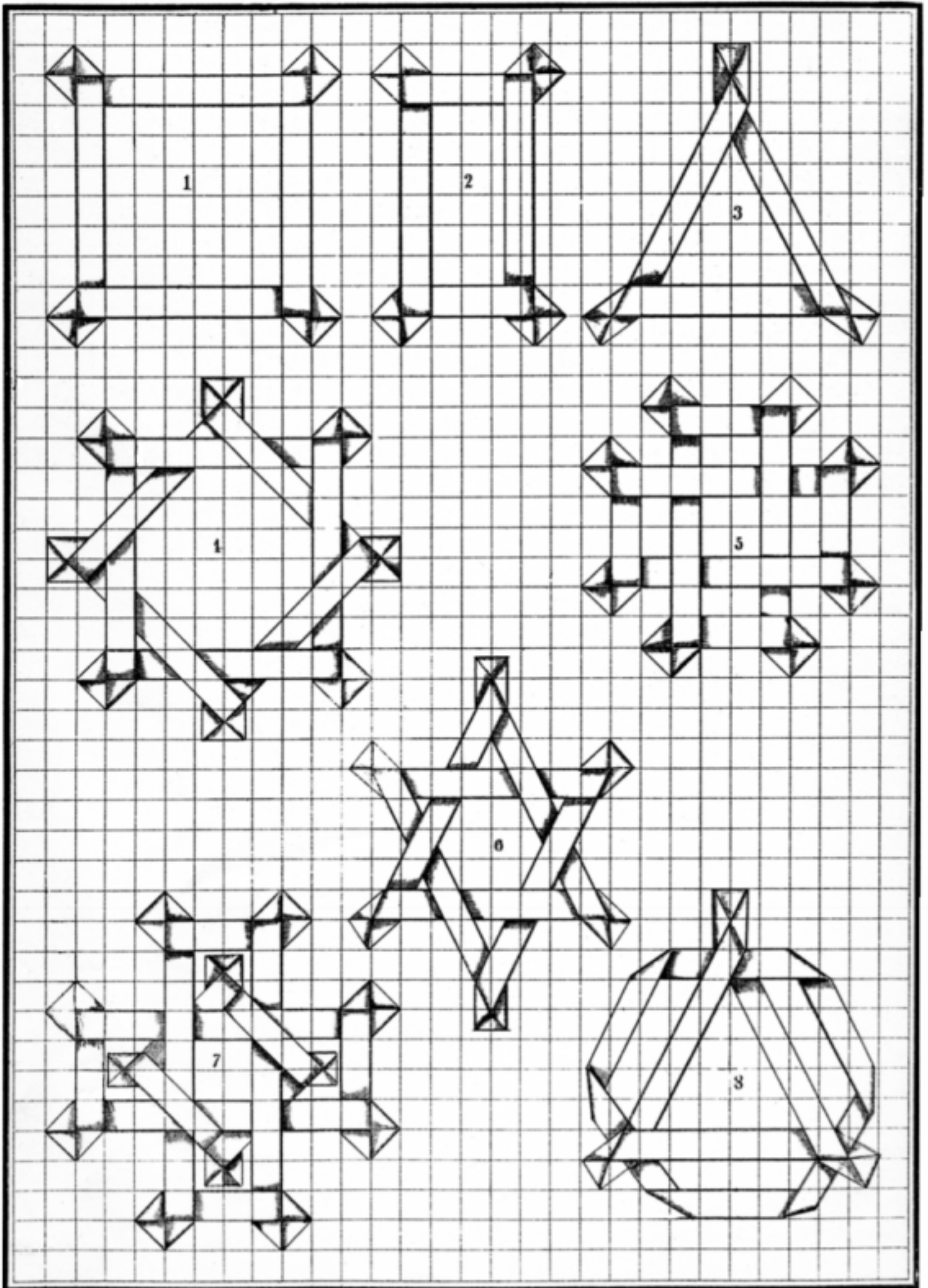

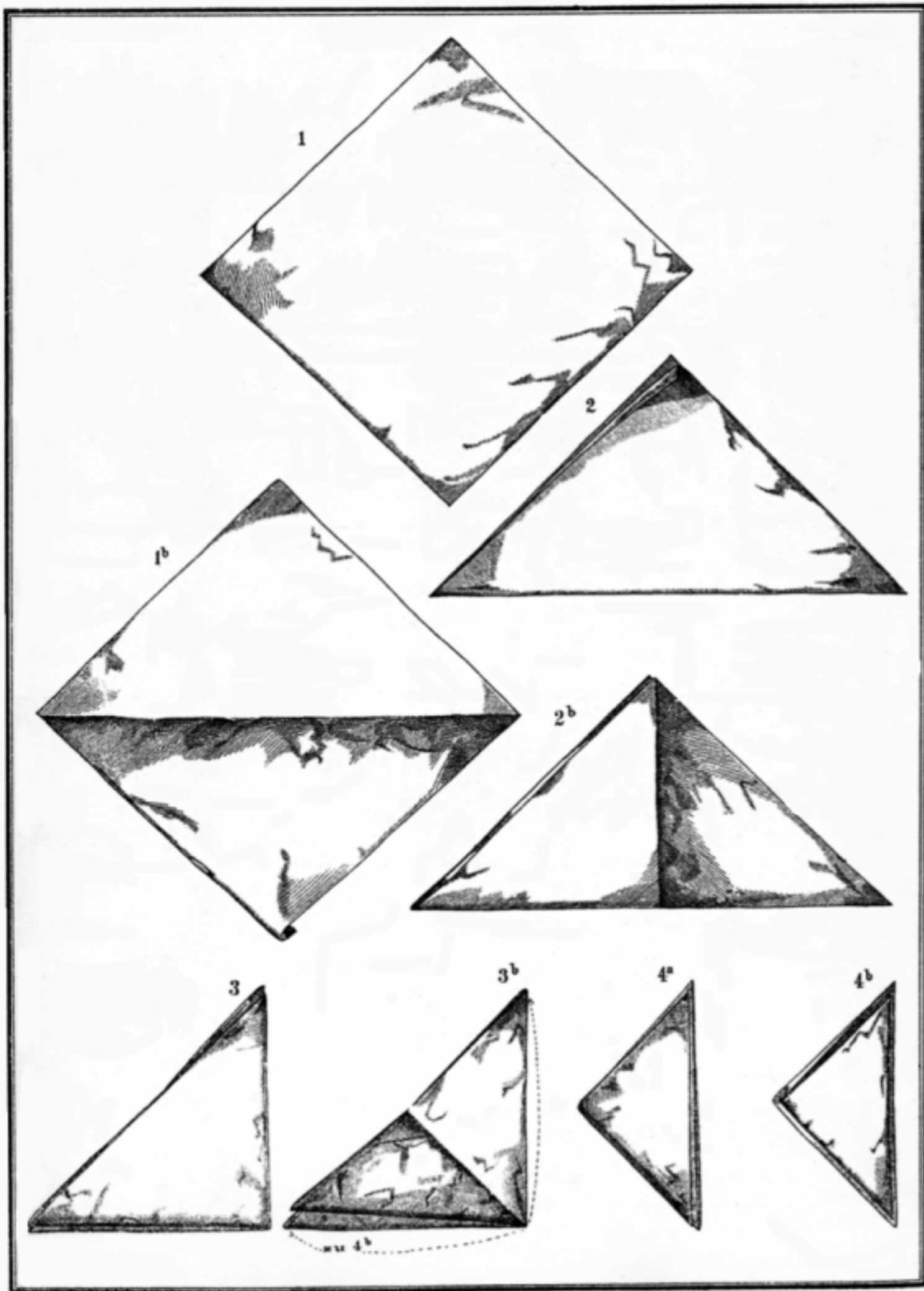

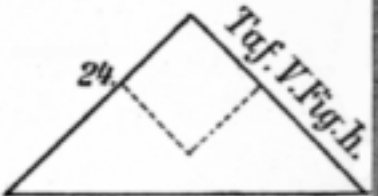
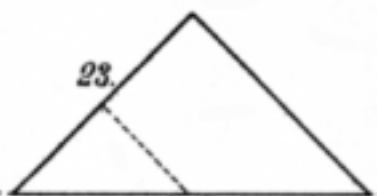
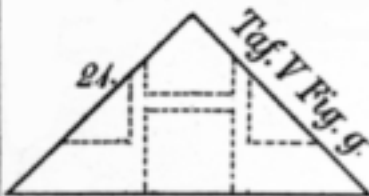
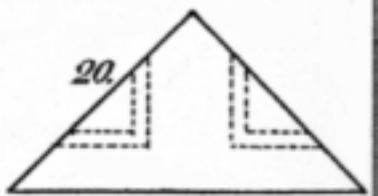
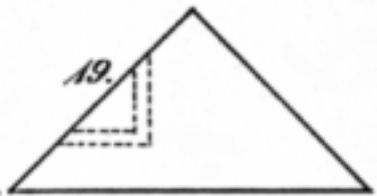
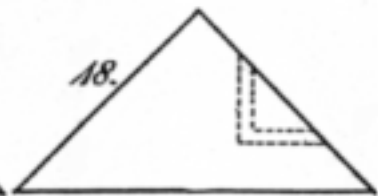
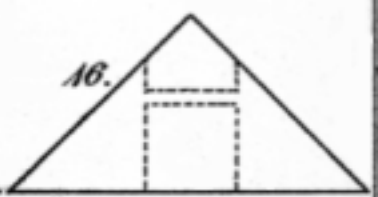
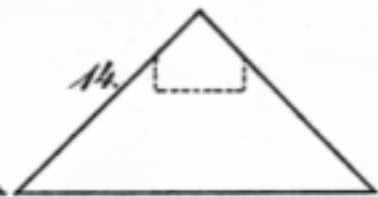
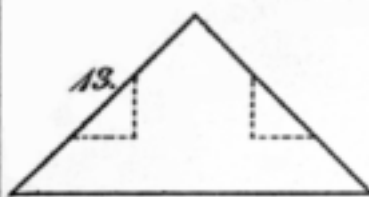
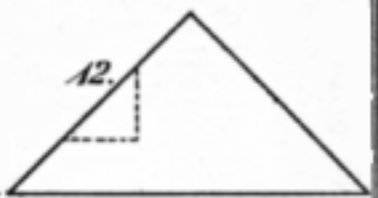
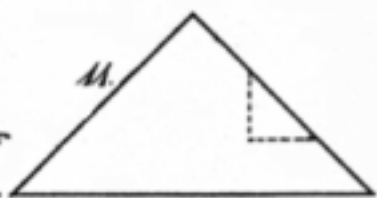
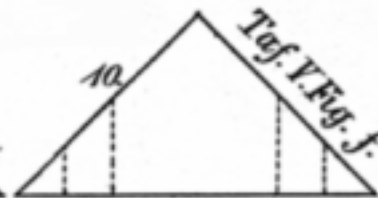
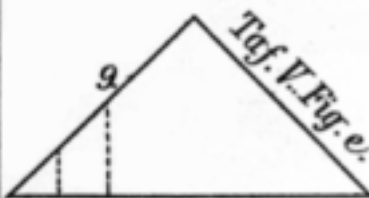
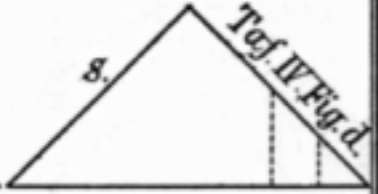
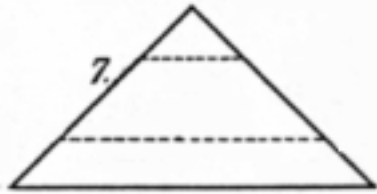
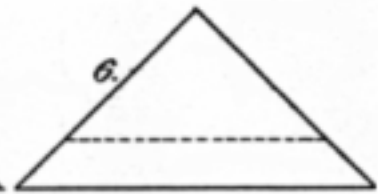
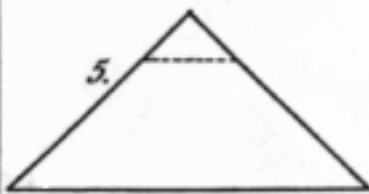
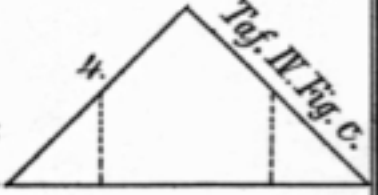
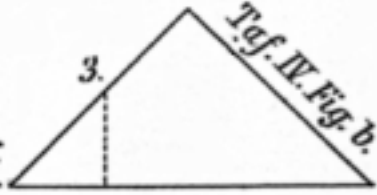
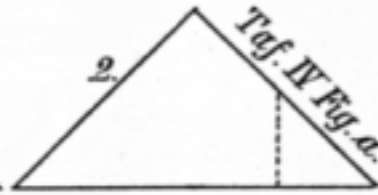

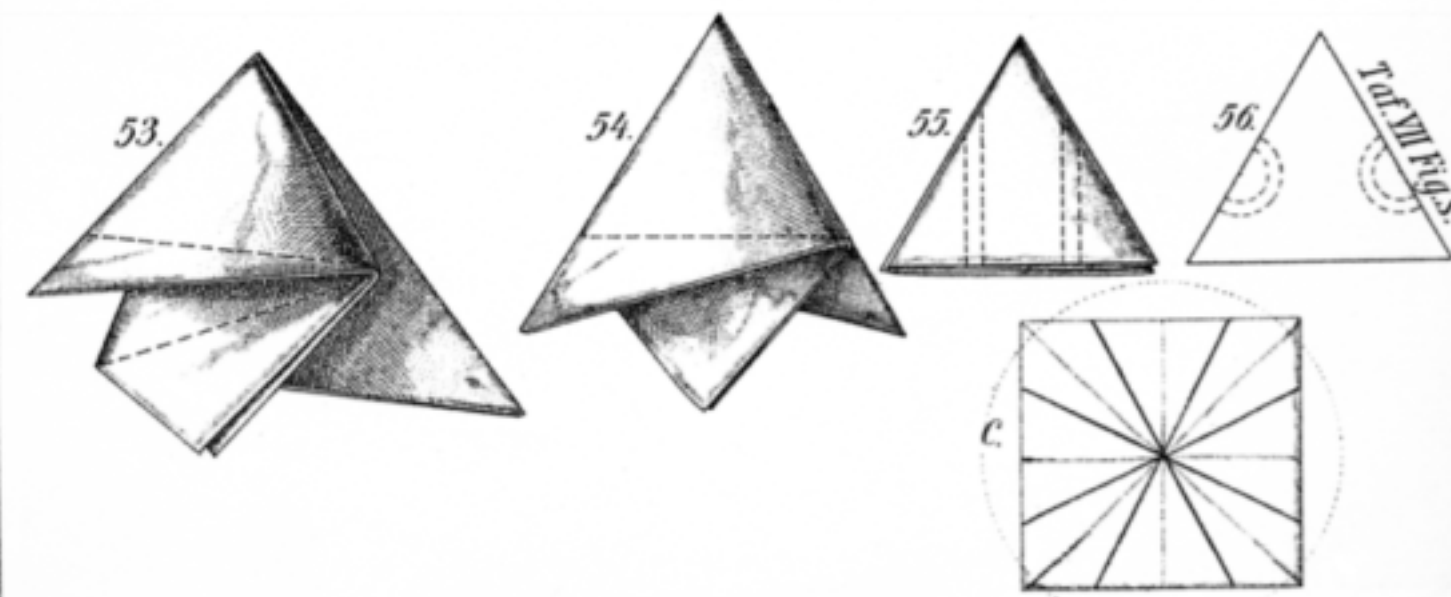
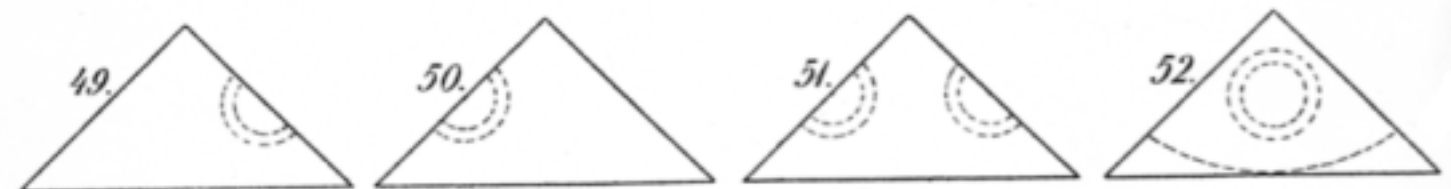
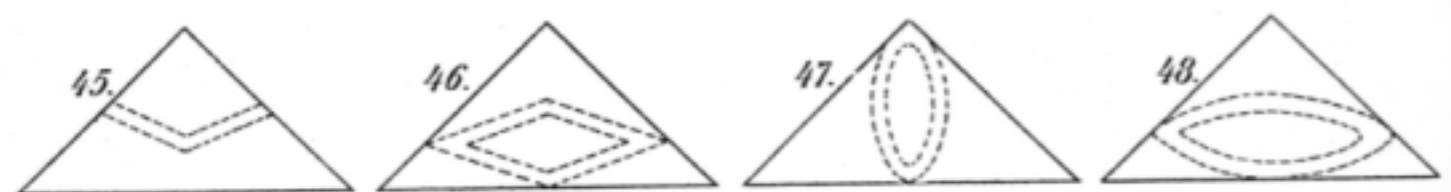
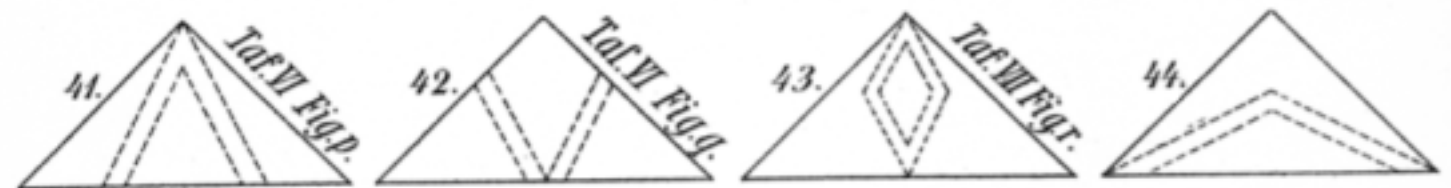
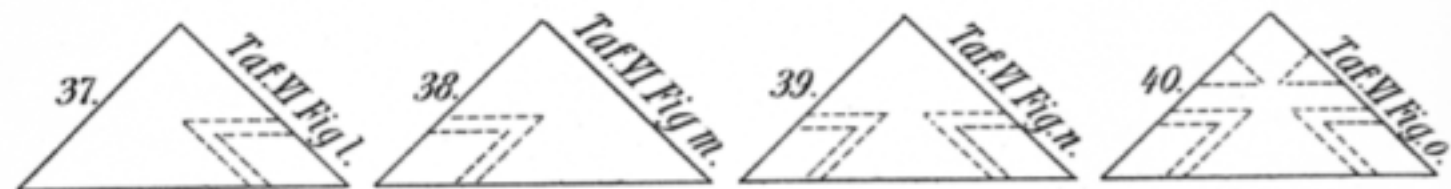
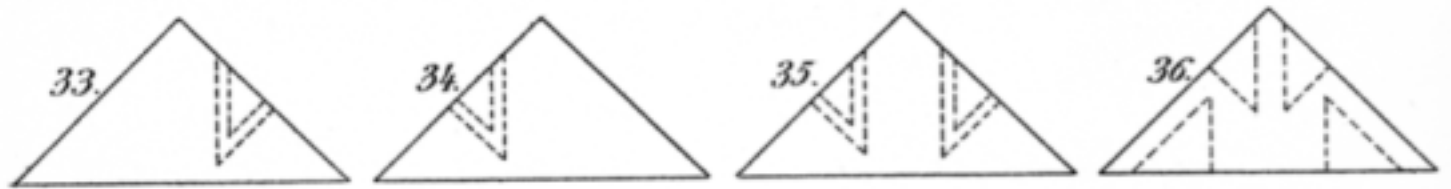
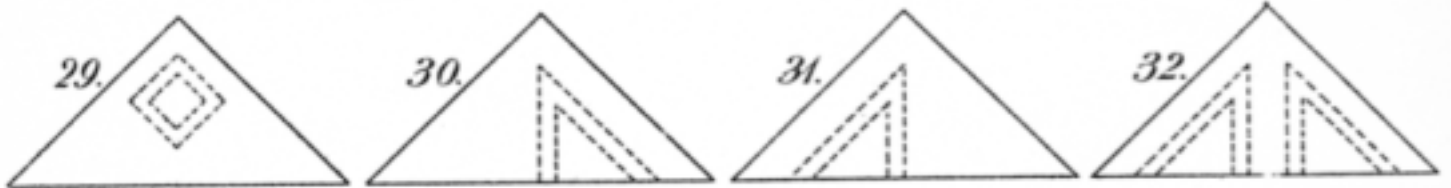

57



58



59



60.



a.

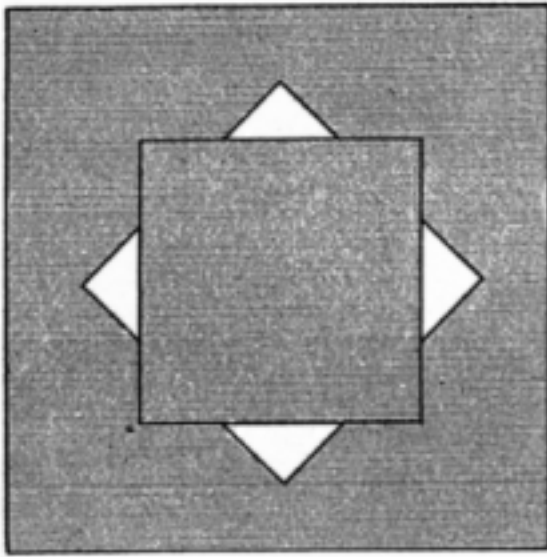

b.

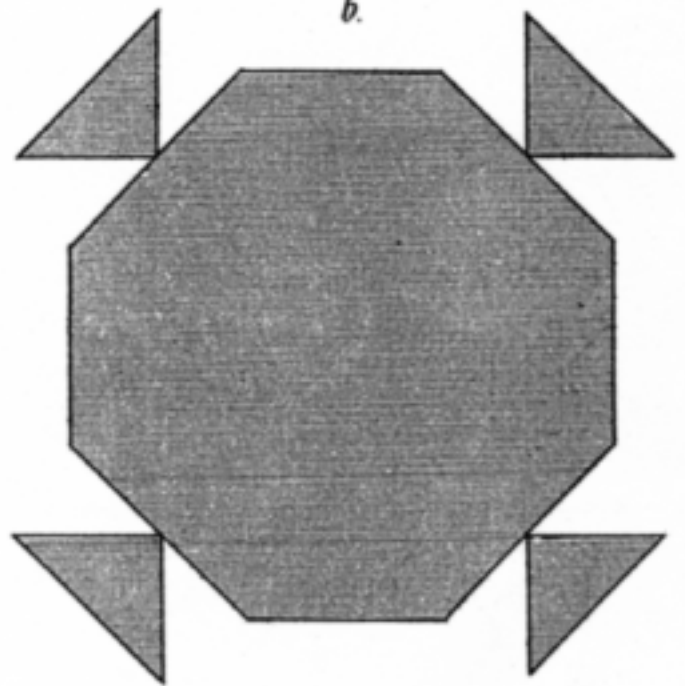

c.

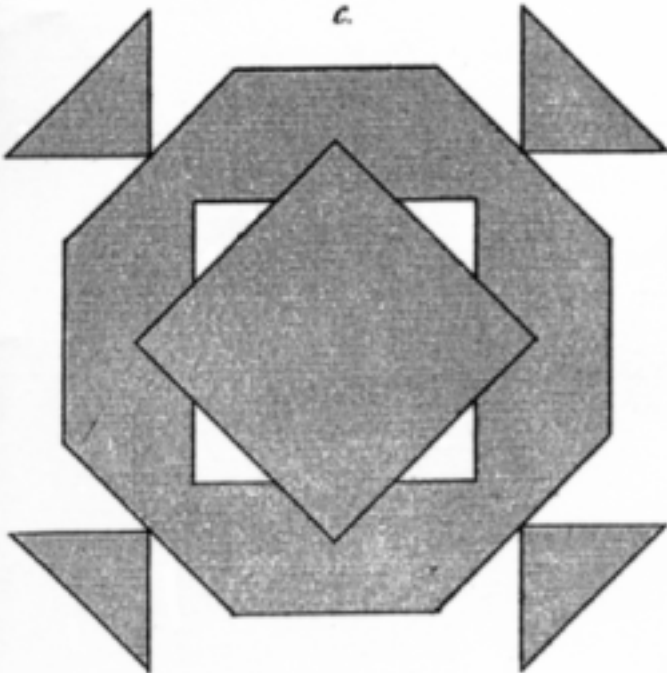

d.

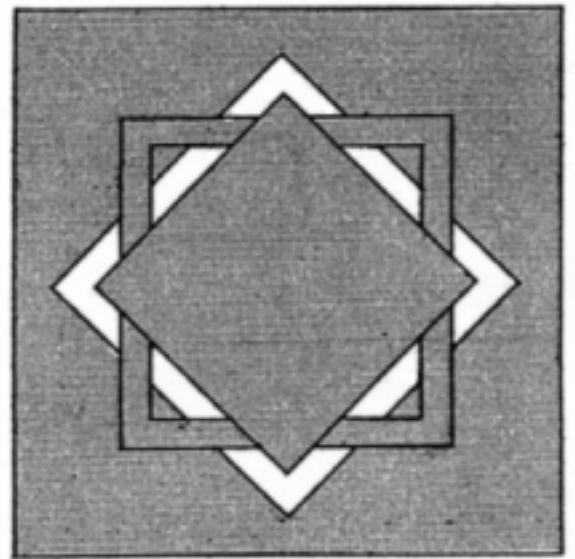

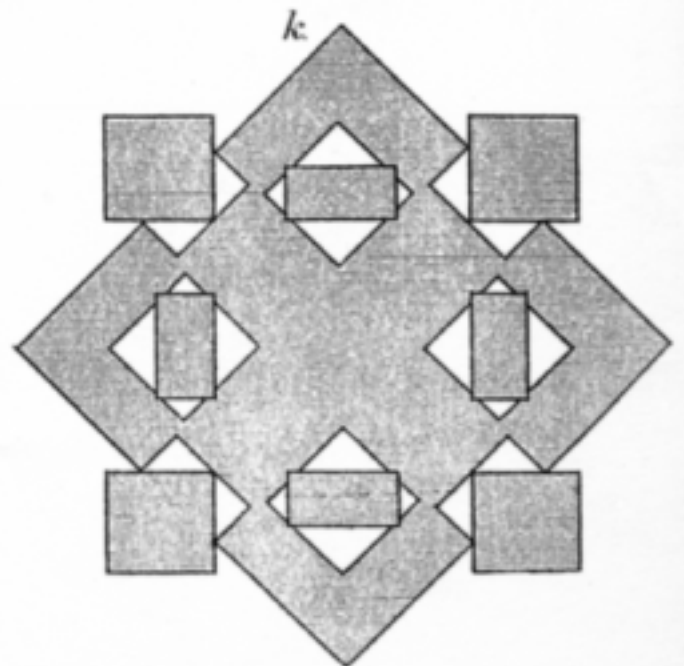
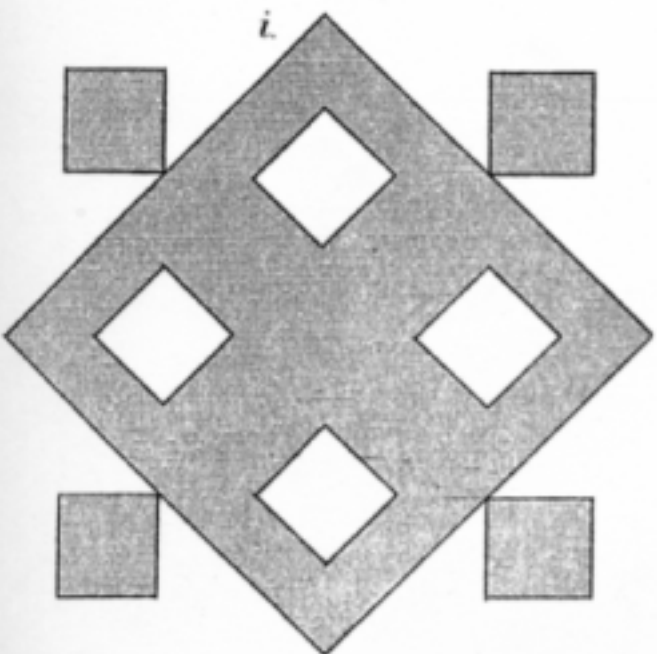
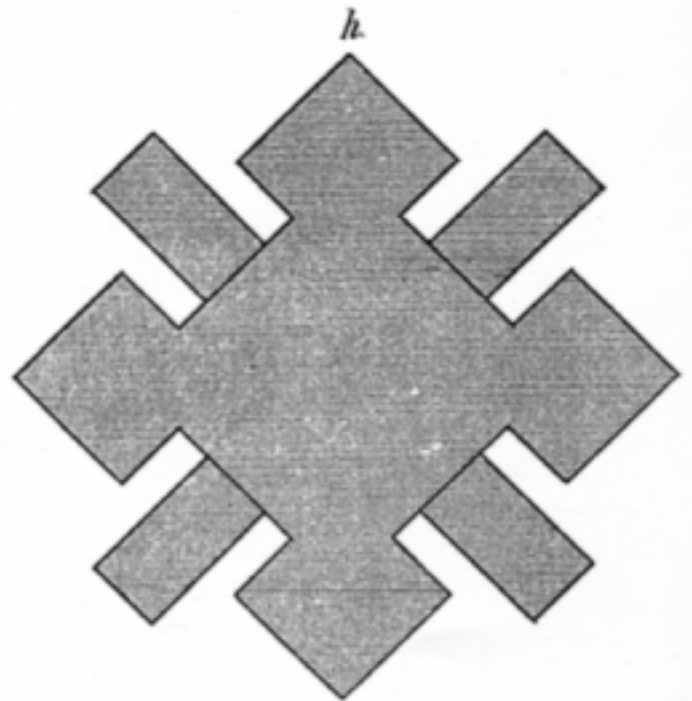
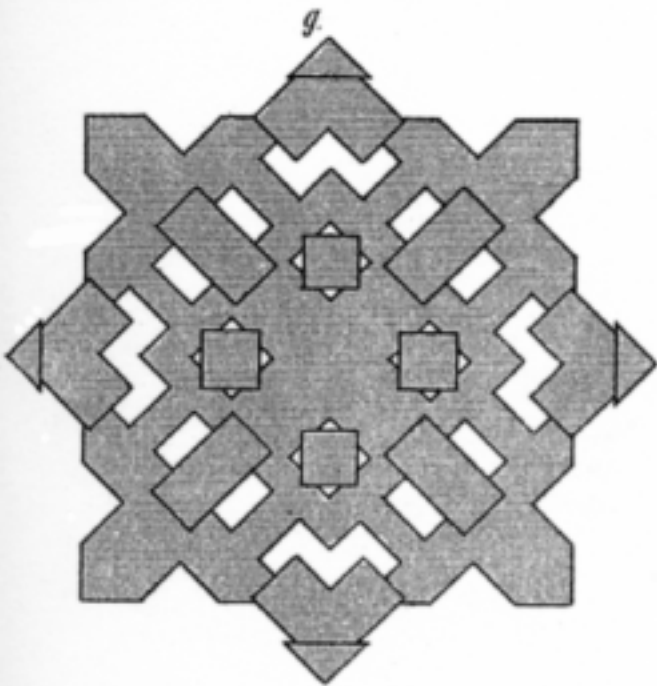
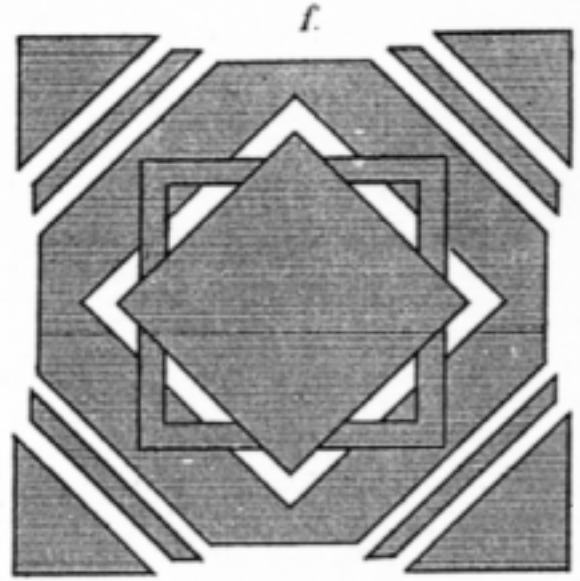
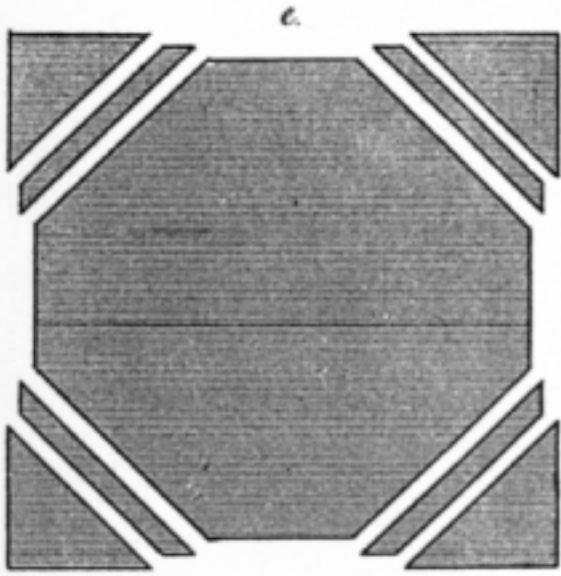

l

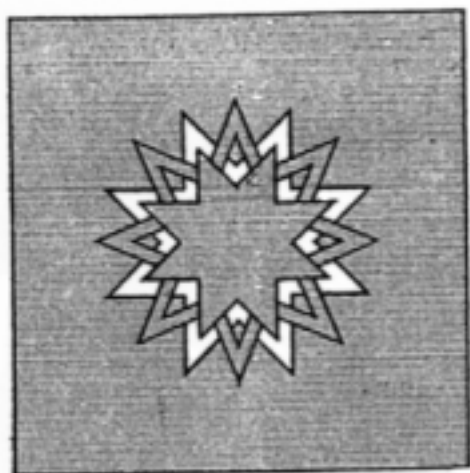

m

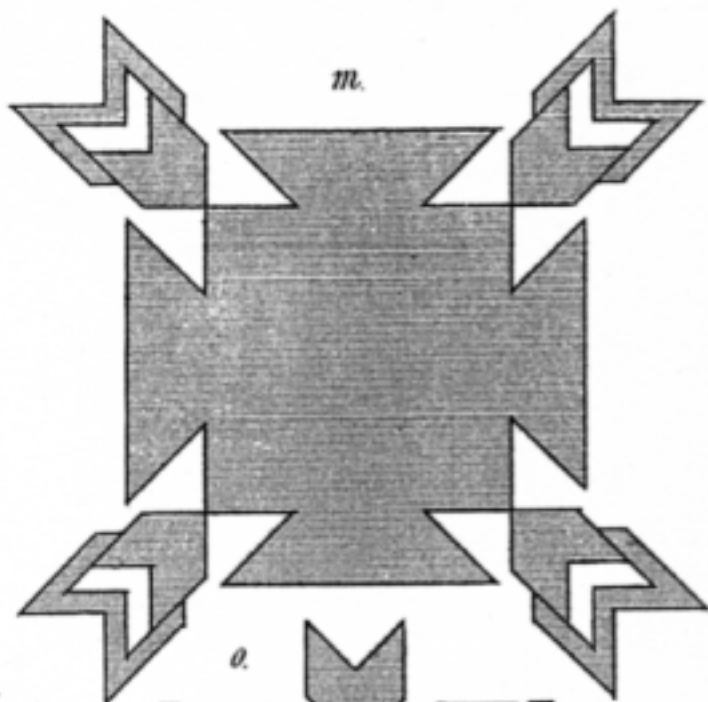

n

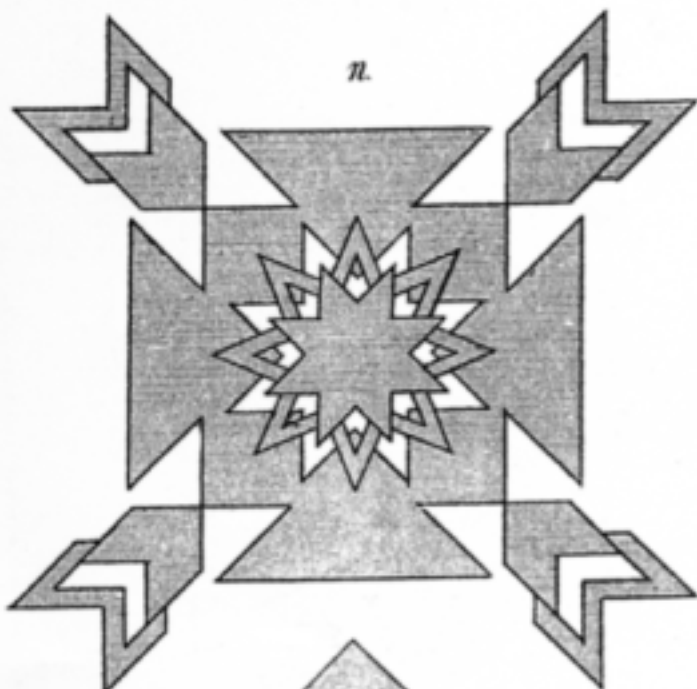

o

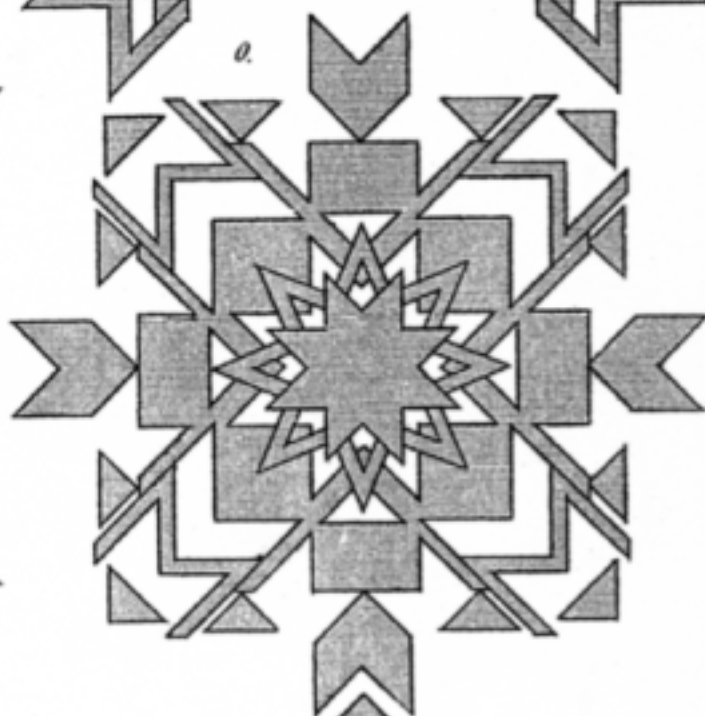

p

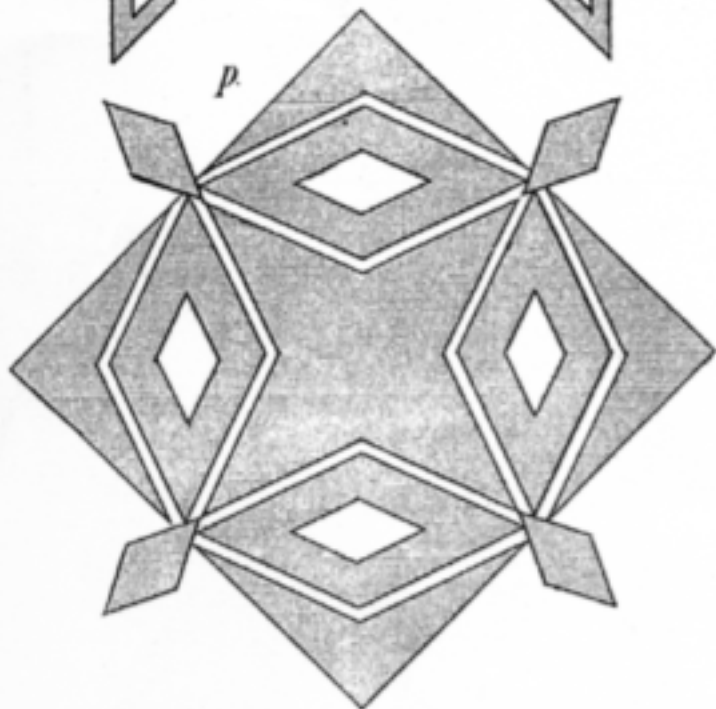

q

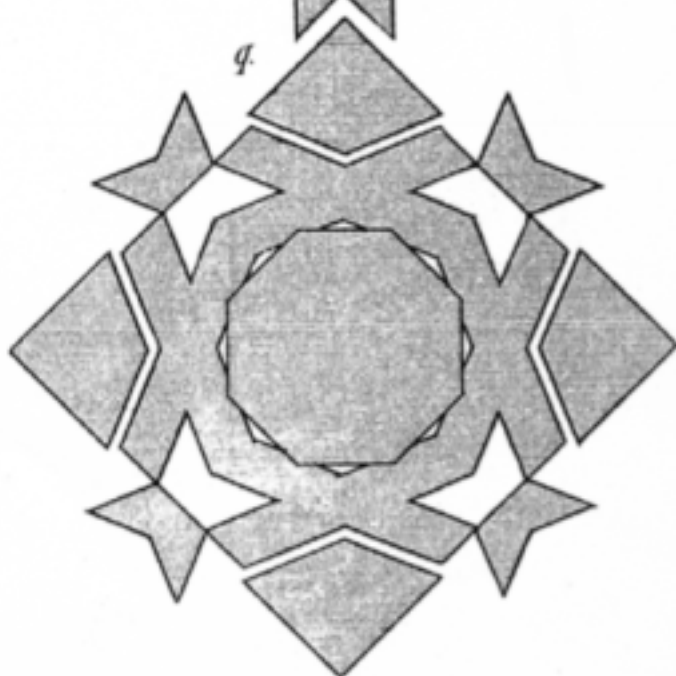

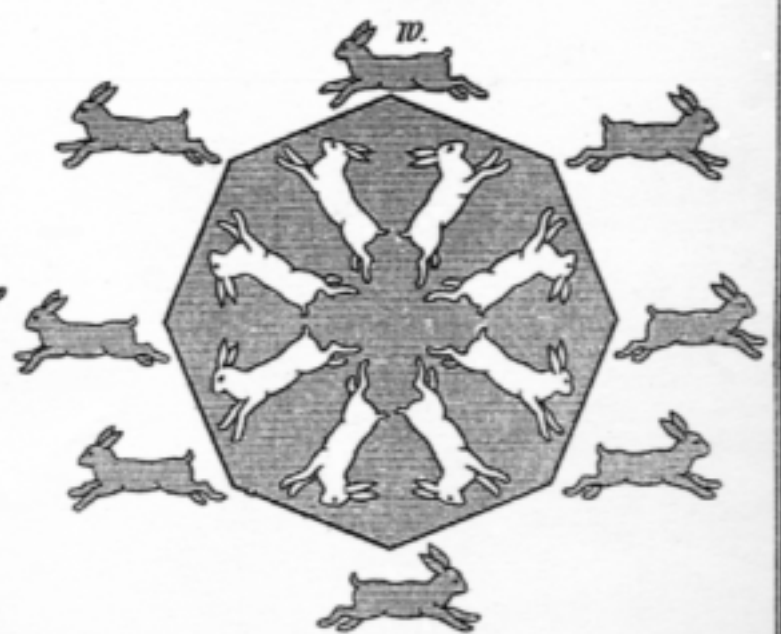
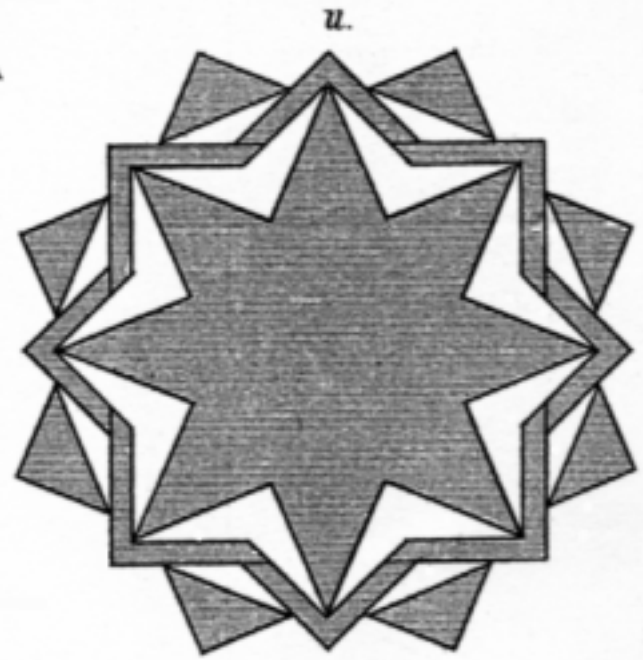
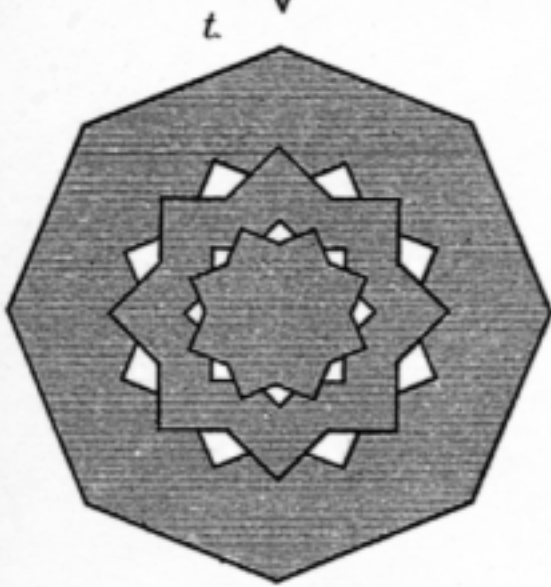
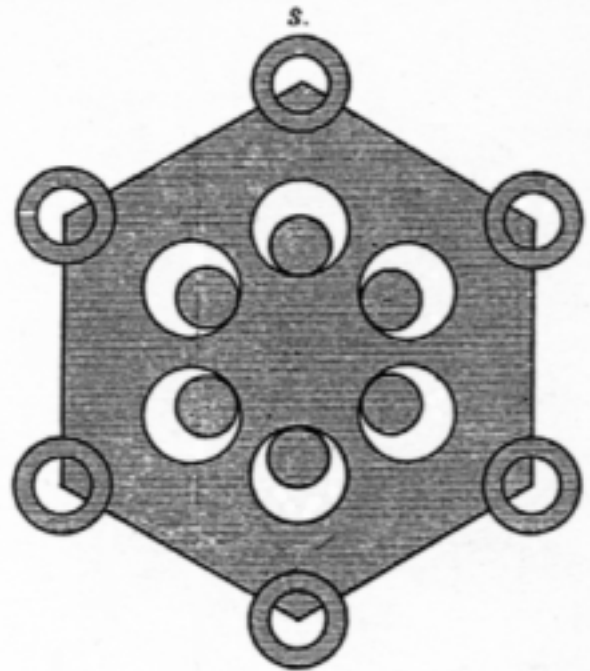
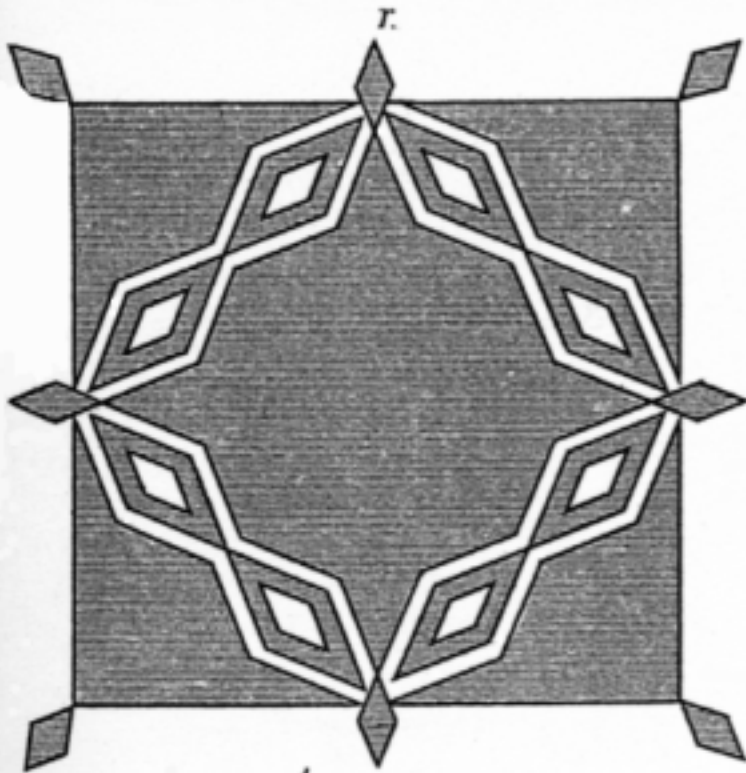

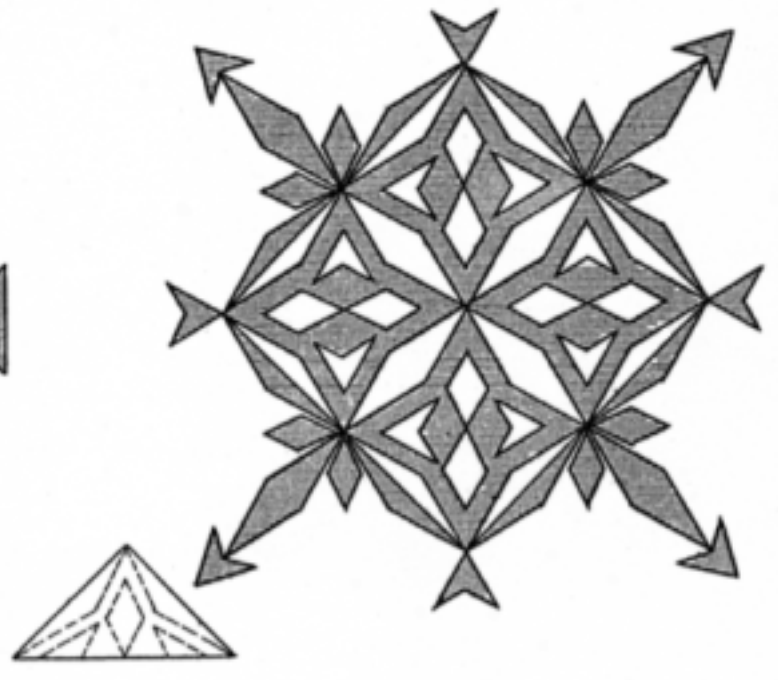
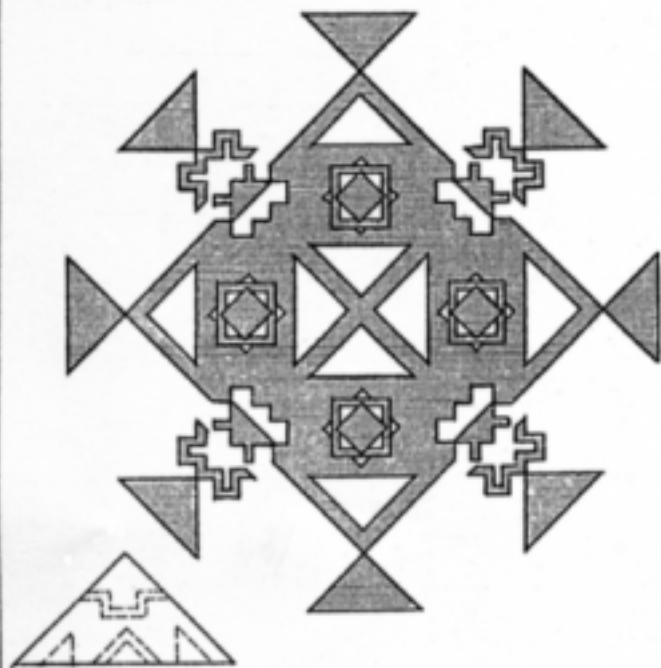
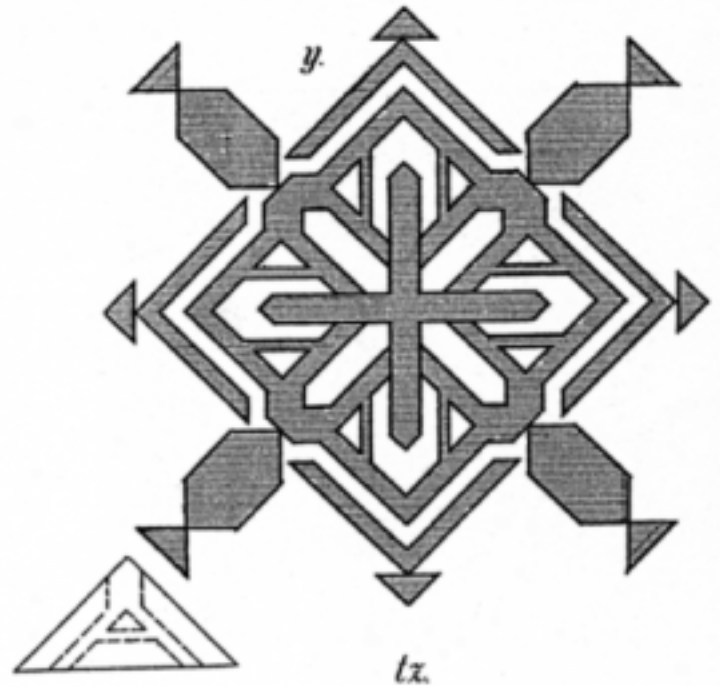
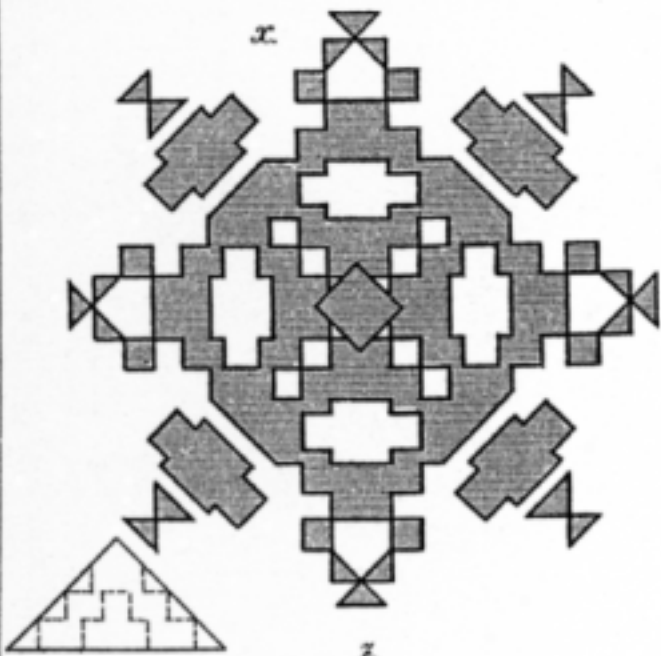

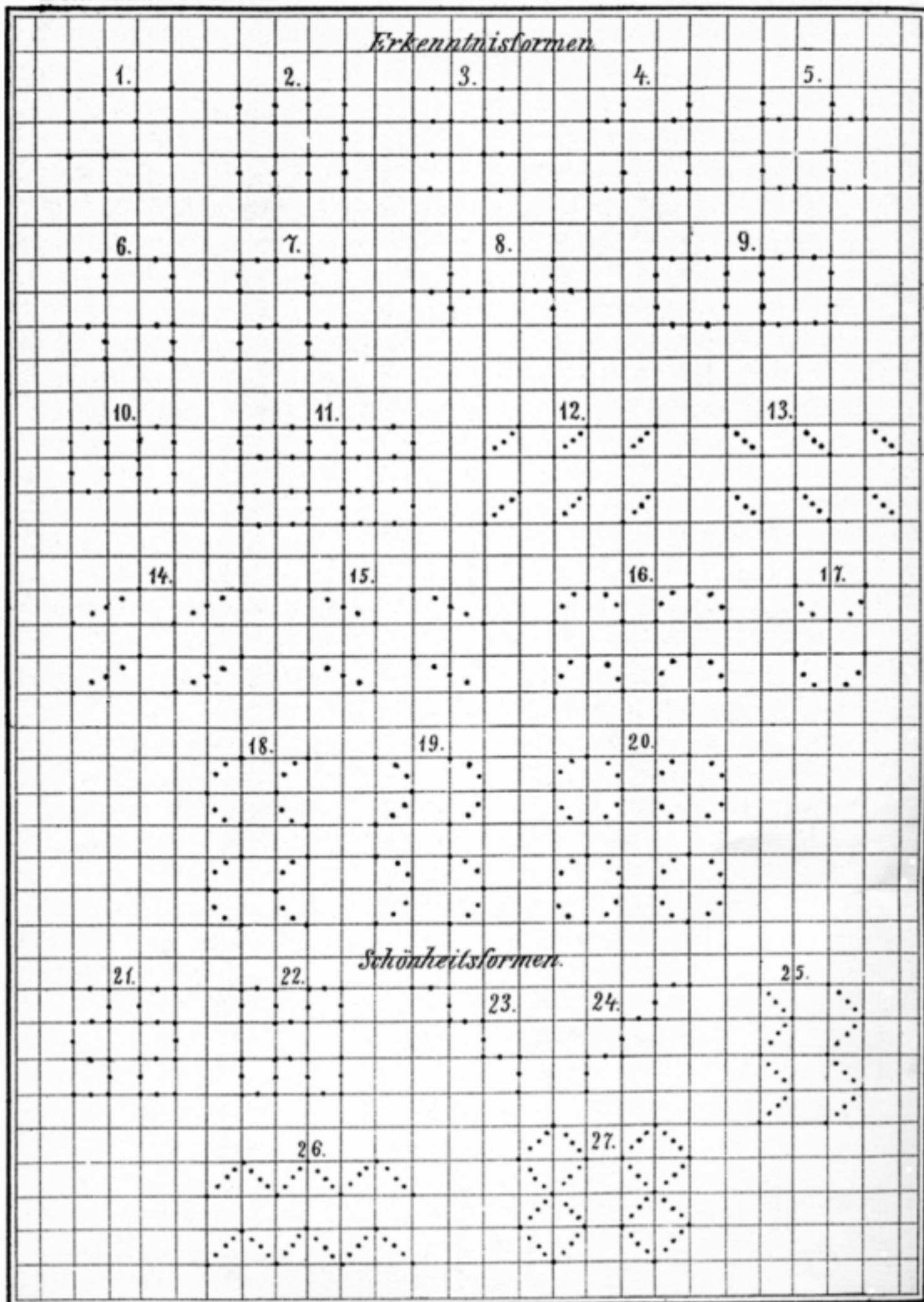

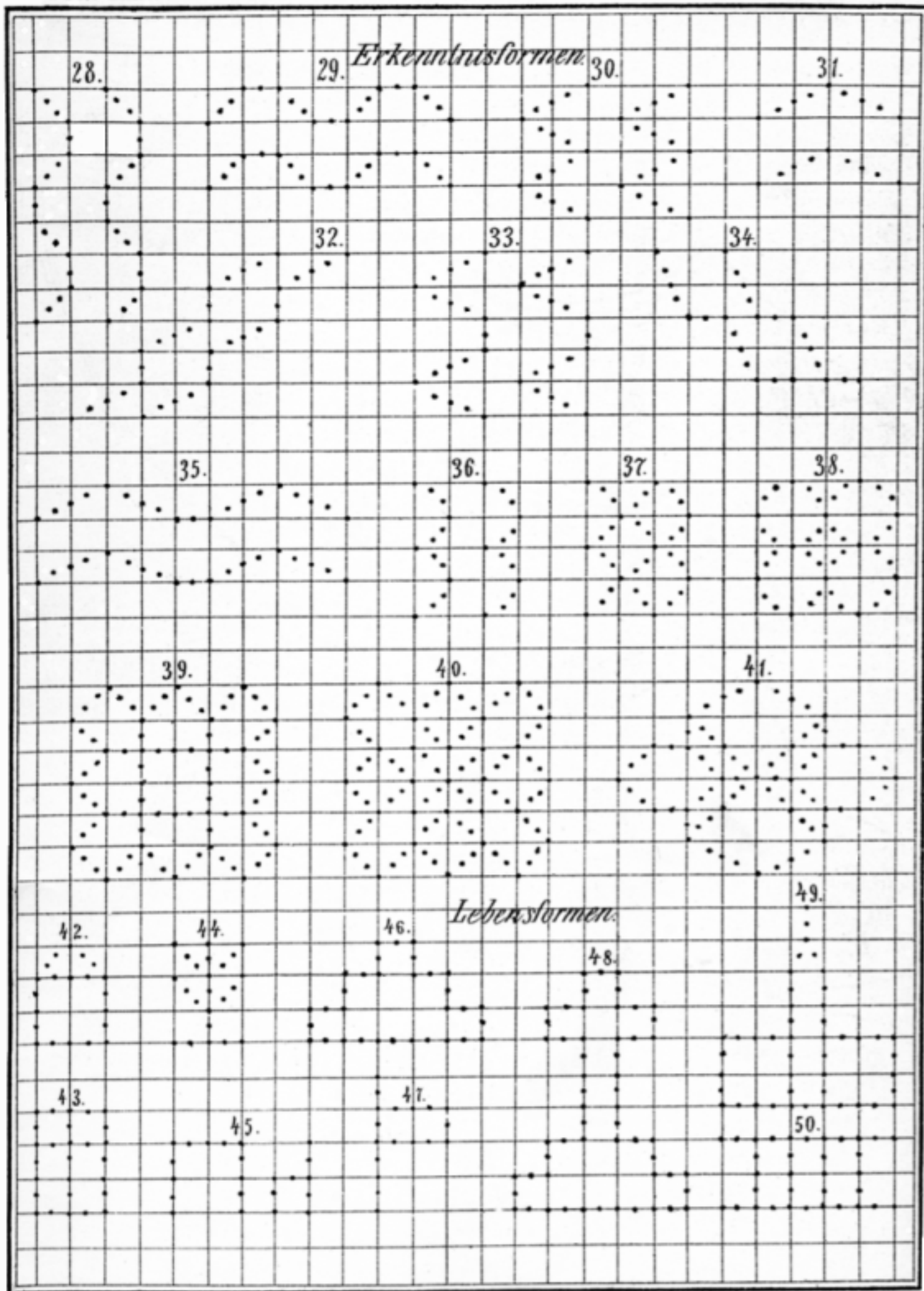

Erfindungen.

51.



52.



53.



Erkenntnisformen.

sind dieselben, wie Tafel I von N^o 2 bis N^o 20 der Ausstechschule.

Schönheitsformen.

21.

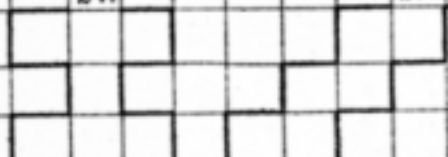

22.

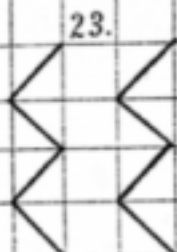

23.

24.

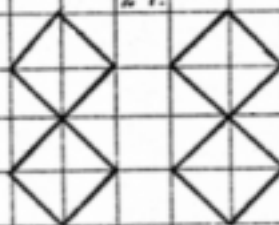

25.

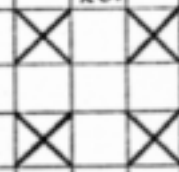

26.

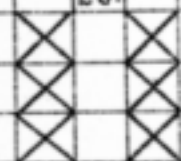

27.

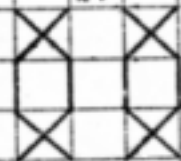

28.

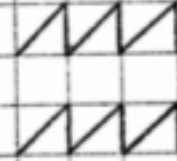

29.



30.



31.

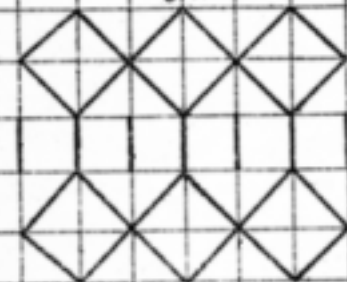

32.

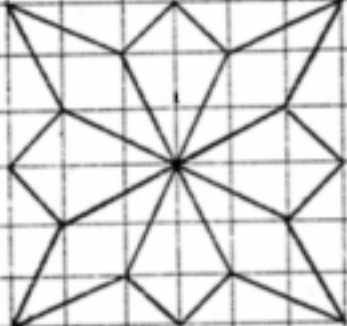

33.

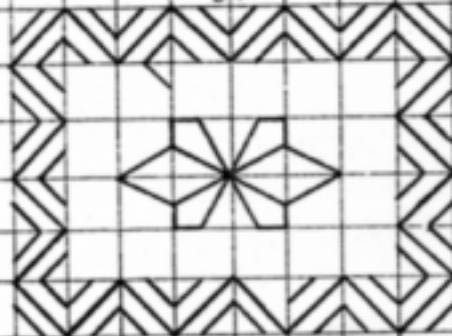

34.

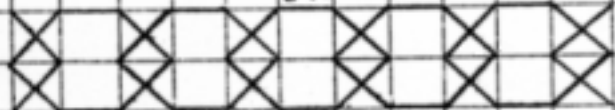

Lebensformen.

36.

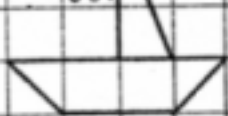

37.

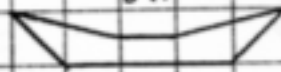

35.



39.

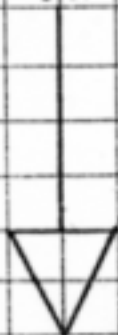

40.



41.

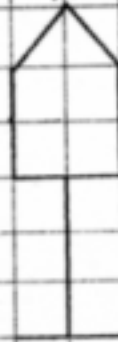

42.



38.

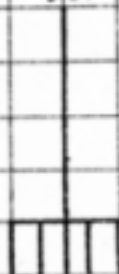



43.

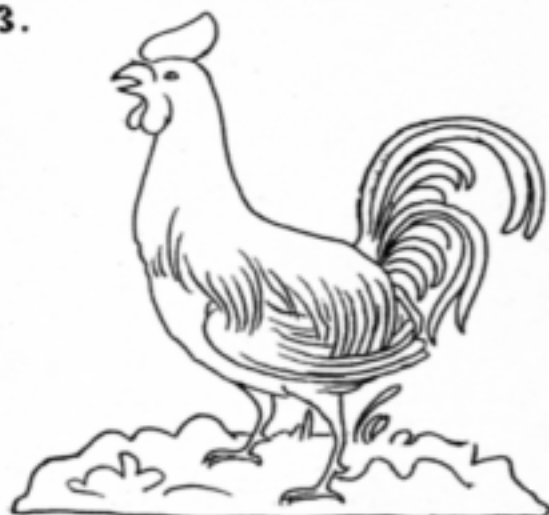

44.

45.

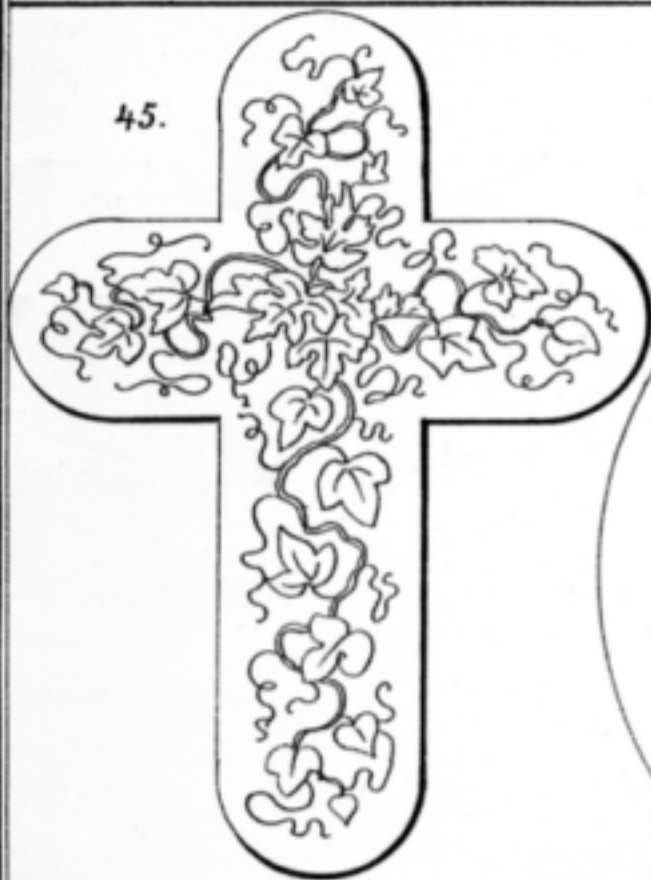

46.

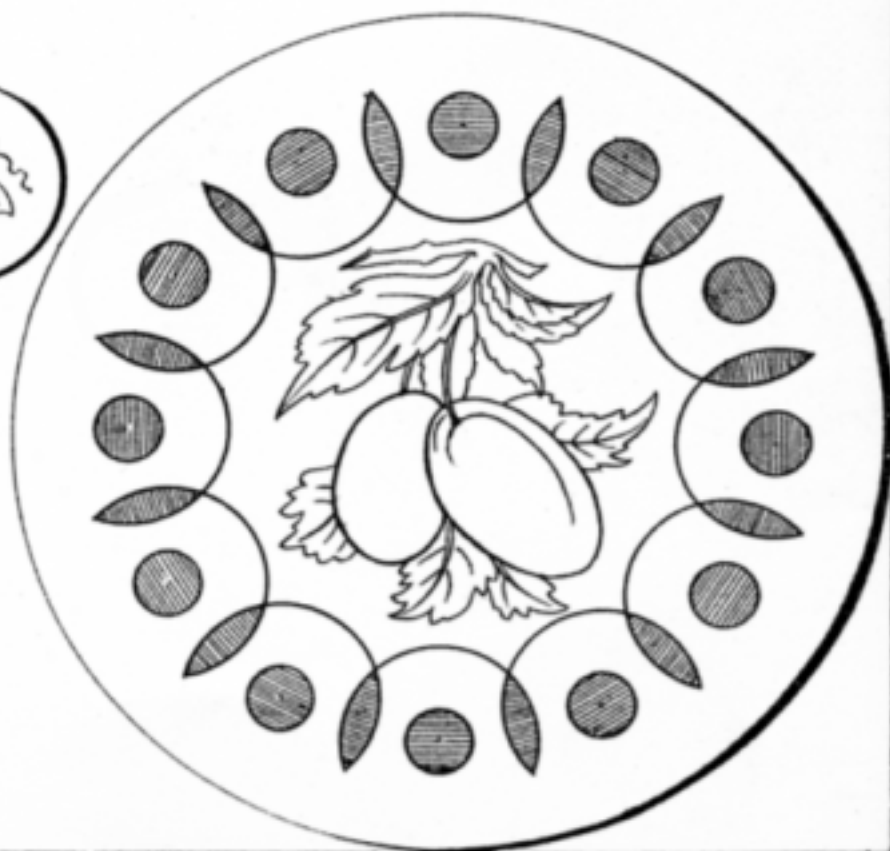

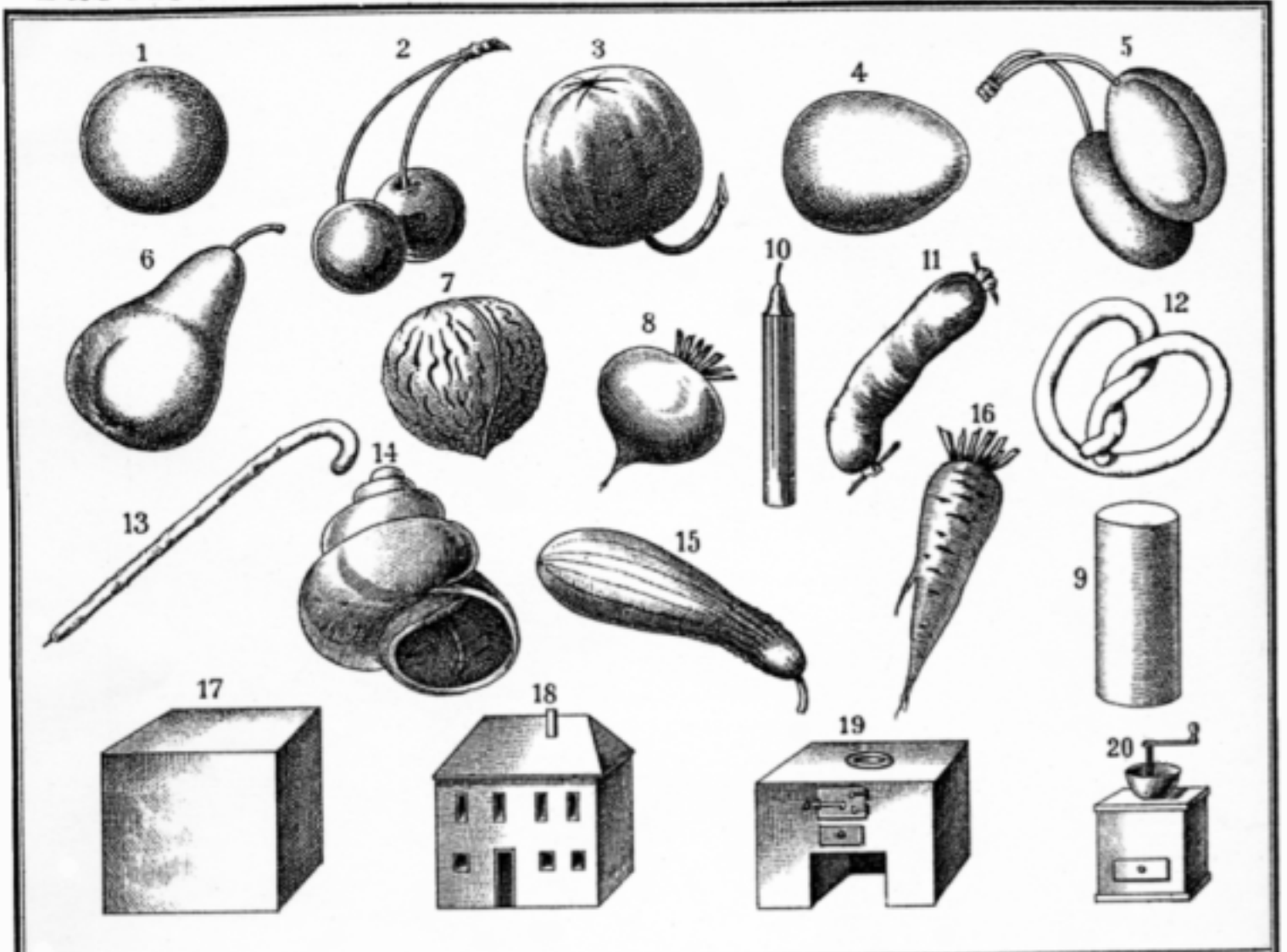

Erfindungen von Kindern.





Fig. 1.



Fig. 2.



Fig. 3.



Fig. 4.



Fig. 5.



Fig. 6.



Fig. 7a.



Fig. 7b.



Fig. 7c.



Fig. 7d.



Fig. 8.



Fig. 9.



Fig. 10.



Fig. 11 a.



Fig. 11 b.



Fig. 11 c.



Fig. 12 a.

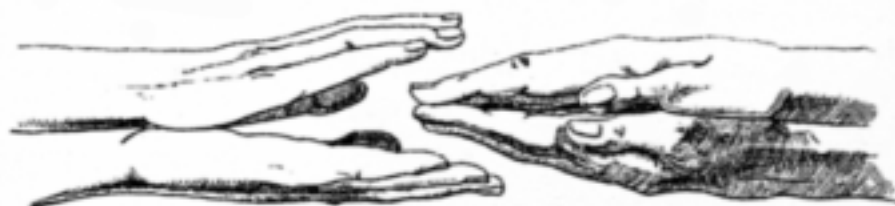

Fig. 12 b.



Fig. 13.



Fig. 14.



Fig. 15.



Fig. 16.

(Schattenbilder.)

